

### **VISION:**

To ensure that the Diploma level Technical Education constantly matches the latest requirements of Technology and industry and includes the all-round personal development of students including social concerns and to become globally competitive, technology led organization.

### **MISSION:**

To provide high quality technical and managerial manpower, information and consultancy services to the industry and community to enable the industry and community to face the challenging technological & environmental challenges.

### **QUALITY POLICY:**

We, at MSBTE are committed to offer the best in class academic services to the students and institutes to enhance the delight of industry and society. This will be achieved through continual improvement in management practices adopted in the process of curriculum design, development, implementation, evaluation and monitoring system along with adequate faculty development programmes.

### **CORE VALUES:**

**MSBTE believes in the following:**

- Skill development in line with industry requirements
- Industry readiness and improved employability of Diploma holders
- Synergistic relationship with industry
- Collective and Cooperative development of all stake holders
- Technological interventions in societal development
- Access to uniform quality technical education.

**A Laboratory Manual  
for  
Engineering Mechanics**

**(312312)**

**SEMESER-II**

**“K-SCHEME”**

**(AE/AL/CE/CH/CR/CS/LE/ME/MK/PG)**



**Maharashtra State  
Board of Technical Education, Mumbai.  
(Autonomous) (ISO:9001:2015) (ISO/IEC 27001:2013)**



Maharashtra State Board of Technical Education, Mumbai  
(Autonomous) (ISO: 9001: 2015) (ISO/IEC 27001:2013)  
4<sup>th</sup> Floor, Government Polytechnic Building, 49, Kherwadi,  
Bandra (East), Mumbai – 400051,  
(Printed On \_\_\_\_\_, 2024)



## Maharashtra State Board of Technical Education, Mumbai.

### Certificate

This is to certify that Mr. / Ms. ....

Roll No.....of Second semester of Diploma in

.....of

Institute,.....

.....(Code:.....) has completed

the term work satisfactorily in course **Engineering Mechanics (312312)** for the

academic year 20..... to 20..... as prescribed in the curriculum.

Place: .....

Enrollment No: .....

Date: .....

Exam. Seat No: .....

Subject teacher

Head of the Department

Principal

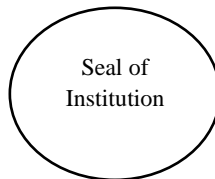



## PREFACE

The development of the critically important industry-relevant abilities and skills is the main goal of any engineering laboratory or field work in the technical education system. In light of this, MSBTE developed the most recent "K" Scheme curricula for engineering diploma programs, emphasizing outcome-based learning. As a result, a sizable portion of the program is dedicated to practical work. This demonstrates how crucial laboratory work is in helping teachers, instructors, and students understand that every minute of lab time must be used efficiently to create these outcomes rather than wasting it on unnecessary activities. Every practical has thus been created to operate as a "vehicle" to help each student acquire this industry-identified capability in order to ensure the effective implementation of this outcome-based curriculum. The "chalk and duster" practice in the classroom is a challenging way to build practical skills. As a result, the development team of the "K" scheme laboratory manual focused on the intended results when creating the practical, as opposed to the customary approach of performing practical's to "verify the theory".

This lab manual is intended to support all parties involved, particularly the students, instructors, and teachers, in helping the students achieve the pre-established goals. It is required of every student to read through the relevant practical process in its entirety and comprehend the bare minimum of theoretical background related to the practical at least one day in advance of the practical. As a crucial starting point for carrying out the practical, each exercise in this handbook starts with establishing the competency, industry-relevant skills, course outcomes, and practical results. After that, the students will learn about the abilities they will acquire through the process outlined there and the safety measures that must be followed, which will enable them to use in addressing real-world situations in their professional life. This manual also offers guidance to educators on how to manage resources so that students follow protocols and safety measures methodically and meet learning objectives. This allows teachers and instructors to effectively support student-centered lab activities through each practical exercise.

Machines play an important role in many aspects of our lives, making many tasks easier and more efficient. For example, machines are used in lift, crane. In same way globally we come across different types of structure created for different purpose and function. While designing the machine or structure analysis of forces and stresses is an important and prerequisite step. Correct analysis is possible only when one knows the types and effect of force acting on the structure. This course provides the scope to understand fundamental concepts of law of machines and their application to different engineering problems. This course is designed to provide basic understanding about different types of forces, moments and their effects on structural elements, which will analyses different structural systems.

Although best possible care has been taken to check for errors (if any) in this laboratory manual, perfection may elude us as this is the first edition of this manual. Any errors and suggestions for improvement are solicited and highly welcome.

### **Program Outcome (POs) to be achieved through Practical**

**PO 1. Basic & Discipline specific knowledge:** Apply knowledge of basic mathematics, sciences and engineering fundamentals and engineering specialization to solve the engineering problems.

**PO 2. Problem Analysis:** Identify and analyze well defined engineering problems using codified standard methods.

**PO 3. Design /Development Solutions:** Design solutions for well-defined technical problems and assist with the design of systems components or processes to meet specified needs.

**PO 4. Engineering tools experimentation and testing:** Apply modern engineering tools and appropriate technique to conduct standard tests and measurements.

**PO 5. Engineering practices for society sustainability and environment:** Apply appropriate technology in context of society, sustainability, environment and ethical practices.

**PO 6. Project Management:** Use engineering management principles individually, as a team member or a leader to manage projects and effectively communicate about well-defined engineering activities.

**PO 7. Lifelong learning:** Ability to analyze individual needs and engage in updating in context of technological changes.

### **List of Relevant Skills**

On the successful completion of the course the students will acquire the required industry relevant skills and they will be able to:

1. Select the suitable machine under given loading condition.
2. Apply the principles of engineering mechanics to find resultant of concurrent, parallel forces acting on structure.
3. Apply the principles of Lami's theorem to find tension in string in three coplanar, concurrent forces.
4. Find support reactions of beam which further use for analysis of beam.
5. Apply the principles of friction in various conditions for useful purpose.
6. Find the centroid and centre of gravity of various components in engineering systems

### **Guidelines to teachers**

1. Teacher should provide the guideline with demonstration of practical to the students with all features.
2. Teacher shall explain prior concepts to the students before starting of each practical.
3. Involve students in performance of each practical.
4. Teacher should ensure that the respective skills and competencies are developed in the students after the completion of the practical exercise.
5. Teachers should give opportunity to students for hands on experience after the demonstration.
6. Teacher is expected to share the skills and competencies to be developed in the students.
7. Teacher may provide additional knowledge and skills to the students even though not covered in the manual but are expected the students by the industry.
8. Finally give practical assignment and assess the performance of students based on task assigned to check whether it is as per the instructions.

### **Instructions to Students**

1. Organize the work in the group and make record all programs.
2. Students shall develop maintenance skill as expected by industries.
3. Student shall attempt to develop related hand-on skills and gain confidence.
4. Student shall develop the habits of evolving more ideas, innovations, skills etc. those included in scope of manual
5. Student shall refer technical magazines.
6. Student should develop habit to submit the practicals on date and time.
7. Student should well prepare while submitting write-up of exercise.
8. Attach /paste separate papers wherever necessary.

### Practical Course Outcome matrix

#### Course Outcomes (Cos)

- CO1 - Select the suitable machine under given loading condition.
- CO2 - Analyze the given force system to calculate resultant force.
- CO3 - Determine unknown force(s) of given load combinations in the given situation.
- CO4 - Apply the laws of friction in the given situation.
- CO5 –Determine the centroid/centre of gravity of the given structural elements of having specific shape and size.

Pr. No.	Title of the Practical	Mapped Course Outcome				
		CO 01	CO 02	CO 03	CO 04	CO 05
01	Collect the photographic information of Indian Knowledge System (IKS) given in various units	√	√	--	--	√
02	*Determine mechanical advantage and velocity ratio of differential axle and wheel for different load and efforts.	√	--	--	--	--
03	Determine mechanical advantage and velocity ratio of worm and worm wheel for different load and efforts.	√	--	--	--	--
04-A OR	Determine mechanical advantage and velocity ratio of single purchase crab winch for different load and effort.	√	--	--	--	--
04-B	Determine mechanical advantage and velocity ratio of double purchase crab winch for different load and effort.	√	--	--	--	--
05	*Determine mechanical advantage and velocity ratio of simple screw jack for different load and effort.	√	--	--	--	--
06	Determine mechanical advantage and velocity ratio of Weston's differential pulley block for different load and efforts.	√	--	--	--	--
07	Determine mechanical advantage and velocity ratio of geared pulley block for different load and efforts.	√	--	--	--	--
08-A OR	Determine mechanical advantage and velocity ratio of two sheave pulley block for different load and efforts.	√	--	--	--	--
08-B	Determine mechanical advantage and velocity ratio of three sheave pulley block for different load and efforts.	√	--	--	--	--
09	*Verify law of polygon of forces using Universal force table for given forces.	--	√	--	--	--
10	*Verify law of moment of forces using law of moment apparatus for given forces.	--	√	--	--	--
11	*Verify the Lamis theorem using Universal force table apparatus for given forces.	--	--	√	--	--

12	*Determine support reactions of simply supported beam using parallel force or beam reaction apparatus for given vertical forces.	--	--	√	--	--
13	*Determine coefficient of friction using friction apparatus for given block on horizontal plane.	--	--	--	√	--
14	Determine coefficient of friction using friction apparatus for given block on inclined plane.	--	--	--	√	--
15	*Verify centroid of plane figure of given dimensions by making simple paper model.	--	--	--	--	√

**Content page****List of Practical's and Formative Assessment sheet.**

<b>Pr. No</b>	<b>Title of the Practical</b>	<b>Page No.</b>	<b>Date of performance</b>	<b>Date of Submission</b>	<b>Assessment marks</b>	<b>Dated sign of teacher</b>	<b>Remarks (if any)</b>
01	Collect the photographic information of Indian Knowledge System (IKS) given in various units	8					
02	*Determine mechanical advantage and velocity ratio of differential axle and wheel for different load and efforts.	13					
03	Determine mechanical advantage and velocity ratio of worm and worm wheel for different load and efforts.	21					
04-A OR	Determine mechanical advantage and velocity ratio of single purchase crab winch for different load and effort.	29					
04-B	Determine mechanical advantage and velocity ratio of double purchase crab winch for different load and effort.	37					
05	*Determine mechanical advantage and velocity ratio of simple screw jack for different load and effort.	45					
06	Determine mechanical advantage and velocity ratio of Weston's differential pulley block for different load and efforts.	53					
07	Determine mechanical advantage and velocity ratio of geared pulley block for different load and efforts.	61					
08-A OR	Determine mechanical advantage and velocity ratio of two sheave pulley block for different load and efforts.	69					
08-B	Determine mechanical advantage and velocity ratio of three sheave pulley block for different load and efforts.	77					

Pr. No	Title of the Practical	Page No.	Date of performance	Date of Submission	Assessment marks	Dated sign of teacher	Remarks (if any)
09	*Verify law of polygon of forces using Universal force table for given forces.	85					
10	*Verify law of moment of forces using law of moment apparatus for given forces.	92					
11	*Verify the Lamis theorem using Universal force table apparatus for given forces.	98					
12	*Determine support reactions of simply supported beam using parallel force or beam reaction apparatus for given vertical forces.	103					
13	*Determine coefficient of friction using friction apparatus for given block on horizontal plane.	109					
14	Determine coefficient of friction using friction apparatus for given block on inclined plane.	115					
15	*Verify centroid of plane figure of given dimensions by making simple paper model.	122					
<b>Total marks :</b>							
<p>These marks are to transferred in preform published by MSBTE</p> <p>*Marked Practical (LLOs) are mandatory.</p> <p>Minimum 80% of above list of lab experiment are to be performed.</p> <p>Judicial mix of LLOs are to be performed to achieve desired outcome.</p>							

**Practical No. 1: Collect the photographic information of Indian Knowledge System (IKS) given in various units**

**I. Practical Significance**

Indian Knowledge Systems (IKS) will actively engage for spreading the traditional knowledge in the field of Engineering & Technology.

**II. Industry / Employer Expected outcomes**

Apply the principles of engineering mechanics to analyze, design and automation the prototypes and equipment's of various industries.

**III. Course Level Learning Outcome(s)**

CO1-Select the suitable machine under given loading condition.  
 CO2-Analyze the given force system to calculate resultant force.  
 CO5-Determine the centroid/center of gravity of gravity of the given structural elements of having specific shape and size.

**IV. Laboratory Learning Outcome(s)**

LLO 1.1 Verify law of machine under the given condition.  
 LLO 1.2 Verify law of moment of forces.  
 LLO 1.3 Understand the centroid of structural component.

**V. Relevant Affective Domain related Outcome (s)**

Follow safety practices.

**VI. Relevant Theoretical Background**

The Indian Knowledge Systems comprise of Jnan, Vignan, and Jeevan Darshan that have evolved out of experience, observation, experimentation, and rigorous analysis. This tradition of validating and putting into practice has impacted our education, arts, administration, law, justice, health, manufacturing, and commerce.

**VII. Required Recourses/Apparatus/Equipment with specifications**

Sr. No.	Particulars	Specifications	Quantity	Remarks (If Any)
1				
2				
3				
4				

**VIII. Precautions to be followed**

.....  
 .....  
 .....

**IX. Procedure**

1. Study the IKS system.
2. Identify various IKS given in various units
3. Student will collect the photographic information of given IKS.

**X. Observations and Calculations**

Identify different IKS in the various units and collect its photographic information.

**XI. Observations Table**

<b>Sr. No.</b>	<b>Unit Name/Instrument Name</b>	<b>Related Photographic Information</b>
1	<b>Unit - I Simple Lifting Machine</b> Hand axe as wedge	
2	<b>Unit - I Simple Lifting Machine</b> Lever in battle, Inclined Plane for loading	
3	<b>Unit - I Simple Lifting Machine</b> Pulleys to lift water in irrigation	
4	<b>Unit - II Analysis of Forces</b> Weighing scale in Mohenjodaro, Harappa	
5	<b>Unit - V Centroid and Centre of Gravity</b> Archery arrowheads in Ramayana	

6	<b>Unit - V Centroid and Centre of Gravity</b> Arch in archaeological structures such as Mahal, GolGumbaz	
---	--	--

**XII. Results**

.....  
.....

**XIII. Interpretation of results**

.....  
.....  
.....  
.....

**XIV. Conclusions and Recommendations**

.....  
.....  
.....  
.....

**XV. Practical Related Questions**

Note: Below given are few sample questions for reference. Teachers must design more such questions so as to ensure the achievement of identified CO. Write answers of minimum three questions.

1. What is IKS?
2. Explain Hand axe as wedge.
3. Discuss about Pulleys to lift water in irrigation.
4. Explain weighing scale in Mohenjodaro, Harappa.
5. Describe arch in archaeological structures such as Mahal, GolGumbaz

**Space for answers**

.....  
.....  
.....  
.....  
.....  
.....  
.....  
.....  
.....  
.....  
.....  
.....  
.....  
.....  
.....  
.....  
.....  
.....  
.....  
.....  
.....



**XVI. References/Suggestions for further Reading**

Sr. No.	Link	Description
1	<a href="http://nitttrc.edu.in/nptel/courses/video/112106286/L01.html">http://nitttrc.edu.in/nptel/courses/video/112106286/L01.html</a>	Introduction to engineering mechanics
2	<a href="https://www.youtube.com/watch?v=kNypk8GReqM">https://www.youtube.com/watch?v=kNypk8GReqM</a>	Law of machine and types of machines useful in industry.
3	<a href="https://www.youtube.com/watch?v=6u_rjLjv-MY&amp;list=PLOSWwFV98rfKXq2KBphJz95rao7q8PpwT&amp;index=3">https://www.youtube.com/watch?v=6u_rjLjv-MY&amp;list=PLOSWwFV98rfKXq2KBphJz95rao7q8PpwT&amp;index=3</a>	Introduction of force system with examples
4	<a href="https://www.youtube.com/watch?v=wfjLNSfPXAI">https://www.youtube.com/watch?v=wfjLNSfPXAI</a>	Centroid of plane/composite figures, C.G. of plane/composite solids

**XVII. Suggested Assessment Scheme**

Performance Indicators		Weightage (%)
<b>Process related: 15 Marks</b>		<b>60 %</b>
1	Collect the basic information of Indian knowledge system.	20 %
2	Identify the IKS in Engineering Mechanics	20 %
3	Working in team.	20 %
<b>Product related: 10 Marks</b>		<b>40 %</b>
1	Collect the photographic information regarding IKS.	20 %
2	Answer to the practical related questions.	10 %
3	Submission of report in time.	10 %
<b>Total: 25 Marks</b>		<b>100 %</b>

Marks Obtained			Dated sign of Teacher
Process Related(15)	Product Related(10)	Total(25)	

## Practical No. 2: Determine mechanical advantage and velocity ratio of differential axle and wheel for different load and efforts.

### I. Practical Significance

There is often a need to lift loads and different lifting machines are used depending on the type of load, intensity of the load and other site conditions. Differential axle and wheel machines are used to lift smaller loads in confined spaces. After conducting this experiment, a graduate engineer will be able to assess the suitability of the differential axle and wheel based on the given load lifting situation.

### II. Industry/Employer Expected Outcomes

Apply the principles of engineering mechanics to analyze, design and automation the prototypes and equipment's of various industries.

### III. Course Level Learning Outcome(s)

CO1-Select the suitable machine under given loading condition.

### IV. Laboratory Learning Outcome(s)

Verify law of machine under the given condition.

### V. Relevant Affective Domain related Outcome(s)

- Follow safety practices and precautions.
- Demonstrate working as a leader/a team member.
- Maintain tools and equipment.

### VI. Relevant Theoretical Background

**Differential axle and wheel:** It is different from simple axle and wheel machine because of its axle configuration. Instead of prismatic single axle in simple wheel and axle, step down axles is used in differential axle and wheel. This machine has a better mechanical advantage as compared to single axle and wheel. Two axles of different diameters are coaxially fitted with the spindle with which a wheel is also coaxially attached. The effort is applied through a wrapped string wound around this wheel. Another string is wound over two axles and carries load with the help of movable pulley. The rope on the wheel and smaller axle are wound in the same direction, whereas that on the larger axle is in opposite direction. When an effort is applied through the wheel, the rope on the wheel and smaller axle get sun wound but gets wound on the larger axle, thus lifting the load.

$$\begin{aligned} \text{Velocity Ratio (V. R.)} &= \frac{\text{Distance Travalled by Effort}}{\text{Distance Travalled by Load}} \\ &= \frac{\pi D}{\pi (d_1 - d_2)} \\ \text{V. R.} &= \frac{2D}{d_1 - d_2} \end{aligned}$$

Where,

- D =Diameter of effort wheel.
- $d_1$  =Diameter of larger axel.
- $d_2$  =Diameter of smaller axle.

**VII. Actual diagram used in laboratory with equipment specifications.**

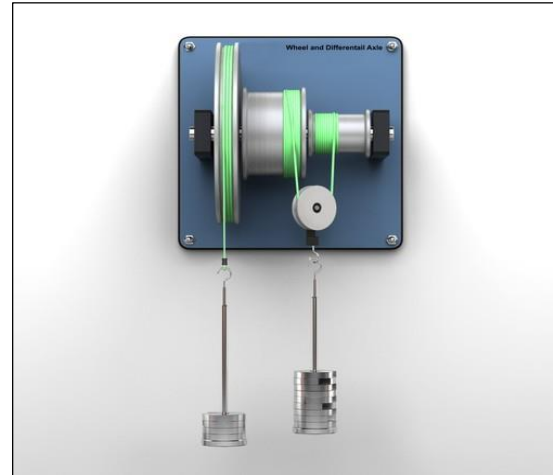
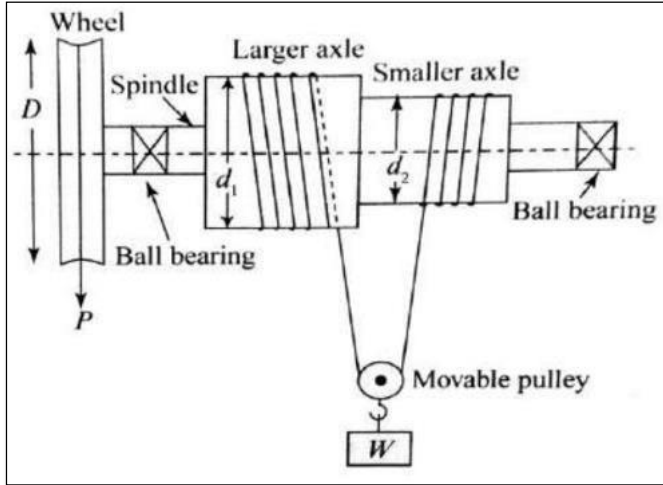

**Fig. 2.1 Differential Axle and Wheel**

**VIII. Requires Recourses/Apparatus/Equipment with Specifications**

Sr. No.	Broad Specifications	Quantity	Remarks (If Any)
1	Differential Axle and Wheel	Differential Axle and wheel(wall mounted unit)with wheel of 40 cm diameter and axles are in steps of 20cm and 10cm reducing diameter	01 for Group of 4 to 5 students.

**IX. Precautions to be followed**

1. The reading must be taken and noted down carefully.
2. The load and effort should move slowly.
3. Effort must be applied gradually.
4. Any overlapping of the string must be avoided.
5. There should be no knot in the string.
6. Only light weights must be used during the course of experiment.

**X. Procedure**

1. Observe the machine carefully and identify the various components of machine.
2. Set the machine and check the reversibility of machine.
3. Calculate friction in the machine at zero load.
4. Apply the load starting with smaller magnitude.
5. Apply the effort for each corresponding load.
6. Record the observations of load and effort in observation table.

7. Take at least five readings.
8. Determine M.A., V.R., Efficiency, Ideal effort and Effort lost in friction,
9. Plot graphs viz. load against effort and load against efficiency.

**Observations and Calculations**

$$V.R. = \frac{2D}{d_1 - d_2} =$$

1. D = .....mm
2. d<sub>1</sub> = .....mm
3. d<sub>2</sub> = .....mm

**XI. Observations Table**

Sr. No.	Load W (N)	Effort P (N)	M.A.	Velocity Ratio	Efficiency η (%)	Ideal Effort P <sub>i</sub> (N)	Effort Lost in Friction P <sub>f</sub> (N)
1							
2							
3							
4							
5							

**Sample Calculations**

$$M.A. = \frac{\text{Load}}{\text{Effort}} = \frac{W}{P} =$$

$$\text{Efficiency } (\eta) = \frac{M.A.}{V.R.} \times 100\% =$$

$$P_i = \frac{W}{V.R.} =$$

$$P_f = P - P_i =$$

Law of Machine is  $P = mW + C$

Where,

$$M = \text{Slope} = \frac{P_2 - P_1}{W_2 - W_1} =$$

$$C = \text{Y intercept (i.e. Machine Friction)} = \text{_____N}$$

**XII. Results**

1. The law of machine is  $P = (\text{.....}) W + (\text{.....}) N$





**XVI. References/Suggestions for further Reading**

Sr. No.	Link	Description
1	<a href="https://www.engineersrail.com/simple-lifting-machine/">https://www.engineersrail.com/simple-lifting-machine/</a>	Introduction of simple lifting machine
2	<a href="https://www.youtube.com/watch?v=kNypk8GReqM">https://www.youtube.com/watch?v=kNypk8GReqM</a>	Law of machine and types of machines use ful in industry.
3	<a href="https://cpimg.tistatic.com/03720838/b/4/WHEEL-DIFFERENTIAL-AXLE.jpg">https://cpimg.tistatic.com/03720838/b/4/WHEEL-DIFFERENTIAL-AXLE.jpg</a>	Differential axel and wheel image
4	<a href="http://nitttrc.edu.in/nptel/courses/video/112106286/L01.html">http://nitttrc.edu.in/nptel/courses/video/112106286/L01.html</a>	Introduction to engineering mechanics

**XVII. Assessment Scheme**

Performance Indicators		Weightage (%)
<b>Process related: 15 Marks</b>		<b>60 %</b>
1	Handling of the machine.	5 %
2	Determination of V. R. of machine.	10 %
3	Applying load and determine effort of machine.	20 %
4	Identify the type of machine i.e. reversible or self-locking.	10 %
5	Calculation of parameters concerned.	10 %
6	Working in team.	5 %
<b>Product related: 10 Marks</b>		<b>40 %</b>
1	Error estimation.	5 %
2	Interpretation of result and graph.	10 %
3	Conclusion and Recommendation.	10 %
4	Answer to the practical related questions.	10 %
5	Submission of report in time.	5 %
<b>Total: 25 Marks</b>		<b>100 %</b>

Marks Obtained			Dated sign of Teacher
Process Related(15)	Product Related(10)	Total(25)	

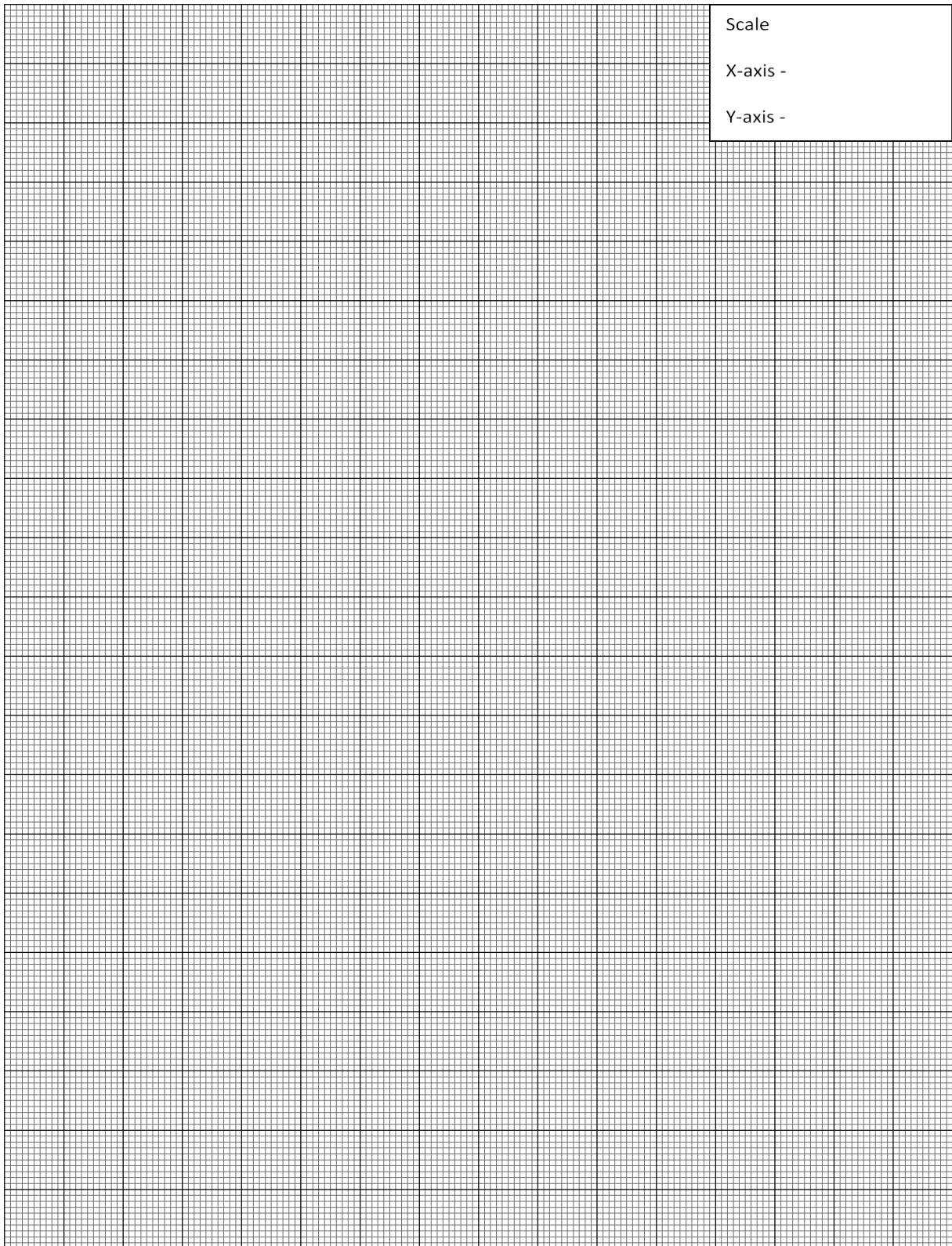

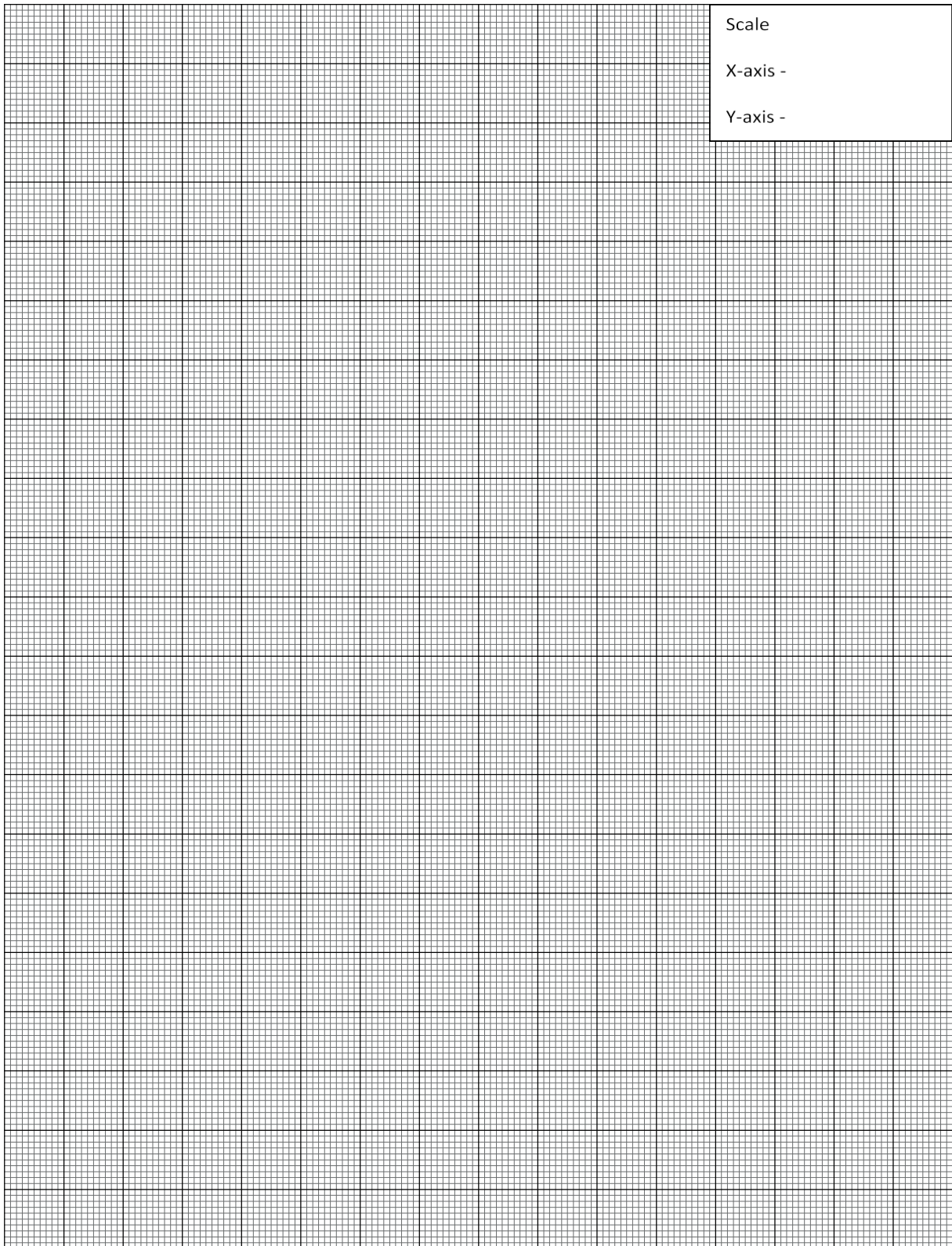

### Practical No. 3: Determine mechanical advantage and velocity ratio of worm and worm wheel for different load and effort.

#### I. Practical Significance

There is often a need to lift loads and different lifting machines are used depending on the type of load, intensity of the load and other site conditions. Worm and worm wheel machines are used for lifting heavy loads in confined spaces. After carrying out this experiment, a qualified engineer can assess the suitability of worms and worm wheels depending on the given lifting situation.

#### II. Industry/Employer Expected Outcomes

Apply the principles of engineering mechanics to analyze, design and automation the prototypes and equipment's of various industries

#### III. Course Level Learning Outcome(s)

CO1-Select the suitable machine under given loading condition.

#### IV. Laboratory Learning Outcome(s)

Verify law of machine under the given condition.

#### V. Relevant Affective Domain related Outcome(s)

- Follow safety practices and precautions.
- Demonstrate working as a leader/a team member.
- Maintain tools and equipment.

#### VI. Relevant Theoretical Background

**Worm and Worm Wheel:** A worm is square-threaded screw and worm wheel is a toothed wheel. In this machine, a worm and worm wheel are geared together maintaining their axes at right angles to each other. An effort wheel or pulley is attached to the worm coaxially so that effort can be applied through a rope wound over the pulley. A load is securely mounted coaxially on worm wheel and load is connected with a separate rope wound around the load drum. For single rotation of effort wheel, effort traverses a distance =  $\pi D$ . For an n- threaded worm, worm pushes the worm wheel through one tooth during single rotation of effort wheel. If the total number of teeth in a worm wheel is T push of one tooth means the load drum traverses through  $(n/T)$  rotations. Thus, when the radius of load drum is r, distance moved by the load =  $2 \pi r \times (n/T)$ .

Therefore, the velocity ratio,

$$\begin{aligned} \text{Velocity Ratio (V. R.)} &= \frac{\text{Distance Traveled by Effort}}{\text{Distance Traveled by Load}} \\ &= \frac{\pi D}{2\pi r \left(\frac{n}{T}\right)} \\ &= \frac{DT}{2nr} \end{aligned}$$

Where,

D = Diameter of effort wheel

$r$  = Radius of pulley  
 $T$  = No. of teeth on the worm wheel  
 $n$  = No. of thread on worm wheel.

**VII. Actual diagram used in laboratory with equipment specifications.**

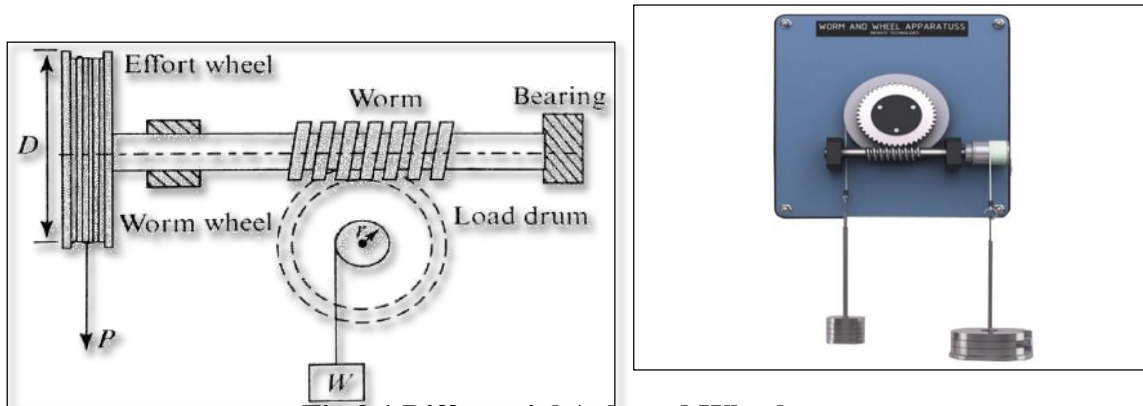

**Fig.3.1 Differential Axle and Wheel**

**VIII. Requires Recourses/Apparatus/Equipment with Specifications**

Sr. No.	Broad Specifications	Quantity	Remarks (If Any)
1	Worm and Worm Wheel	Worm and worm wheel (wall Mounted Unit threaded spindle, load drum, effort wheel; with necessary slotted weights, hanger and thread).	01 for Group of 4 to 5 students.

**IX. Precautions to be followed**

1. The reading must be taken and noted down carefully.
2. The load and effort should move slowly.
3. Effort must be applied gradually.
4. Any overlapping of the string must be avoided.
5. There should be no knot in the string.
6. Only light weights must be used during the course of experiment.
7. Lubricate the screw before starting the experiment.

**X. Procedure**

1. Observe the machine carefully and identify the various components of machine.
2. Set the machine and check the reversibility of machine.
3. Apply the load-on-load drum starting with smaller magnitude.
4. Apply the effort to the effort wheel for each corresponding load.
5. Record the observations of load and effort in observation table. Take at least five readings.
6. Measure the radius of the load drum and the radius of effort wheel.
7. Determine M.A., V.R., Efficiency, Ideal effort and Effort lost in friction,
8. Plot graphs viz. load against effort and load against efficiency.

**Observations and Calculations**

$$V.R. = \frac{DT}{2nr}$$

1. D = ..... mm
2. R = ..... mm
3. T = ..... No.
4. n = ..... No.

**XI. Observations Table**

Sr. No.	Load W (N)	Effort P (N)	M.A.	Velocity Ratio	Efficiency $\eta$ (%)	Ideal Effort $P_i$ (N)	Effort Lost in Friction $P_f$ (N)
1							
2							
3							
4							
5							

**Sample Calculations**

$$M.A. = \frac{\text{Load}}{\text{Effort}} = \frac{W}{P} =$$

$$\text{Efficiency } (\eta) = \frac{M.A.}{V.R.} \times 100\% =$$

$$P_i = \frac{W}{V.R.} =$$

$$P_f = P - P_i =$$

Law of Machine is  $P = mW + C$

Where,

$$M = \text{Slope} = \frac{P_2 - P_1}{W_2 - W_1} =$$

C = Y intercept (i.e. Machine Friction) = \_\_\_\_\_ N

**XII. Results**

1. The law of machine is  $P = (\dots\dots\dots) W + (\dots\dots\dots) N$
2. The average efficiency of machine is = ..... %

**XIII. Interpretation of results**

Machine is .....





**XVII. Suggested Assessment Scheme**

Performance Indicators		Weightage (%)
<b>Process related: 15 Marks</b>		<b>60 %</b>
1	Handling of the machine.	5 %
2	Determination of V. R. of machine.	10 %
3	Applying load and determine effort of machine.	20 %
4	Identify the type of machine i.e. reversible or self-locking.	10 %
5	Calculation of parameters concerned.	10 %
6	Working in team.	5 %
<b>Product related: 10 Marks</b>		<b>40 %</b>
1	Error estimation.	5 %
2	Interpretation of result and graph.	10 %
3	Conclusion and Recommendation.	10 %
4	Answer to the practical related questions.	10 %
5	Submission of report in time.	5 %
<b>Total: 25 Marks</b>		<b>100 %</b>

Marks Obtained			Dated sign of Teacher
Process Related(15)	Product Related(10)	Total(25)	

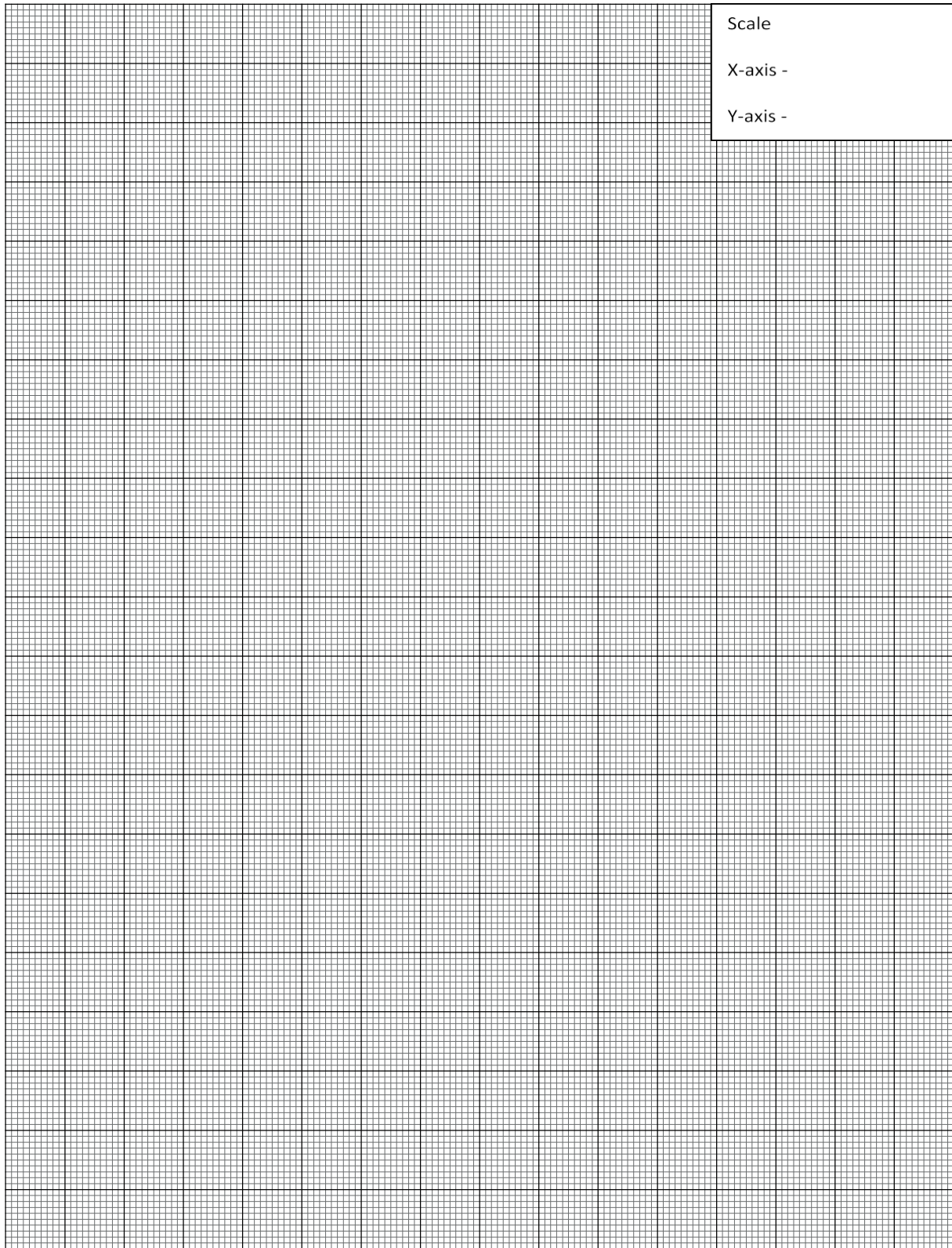

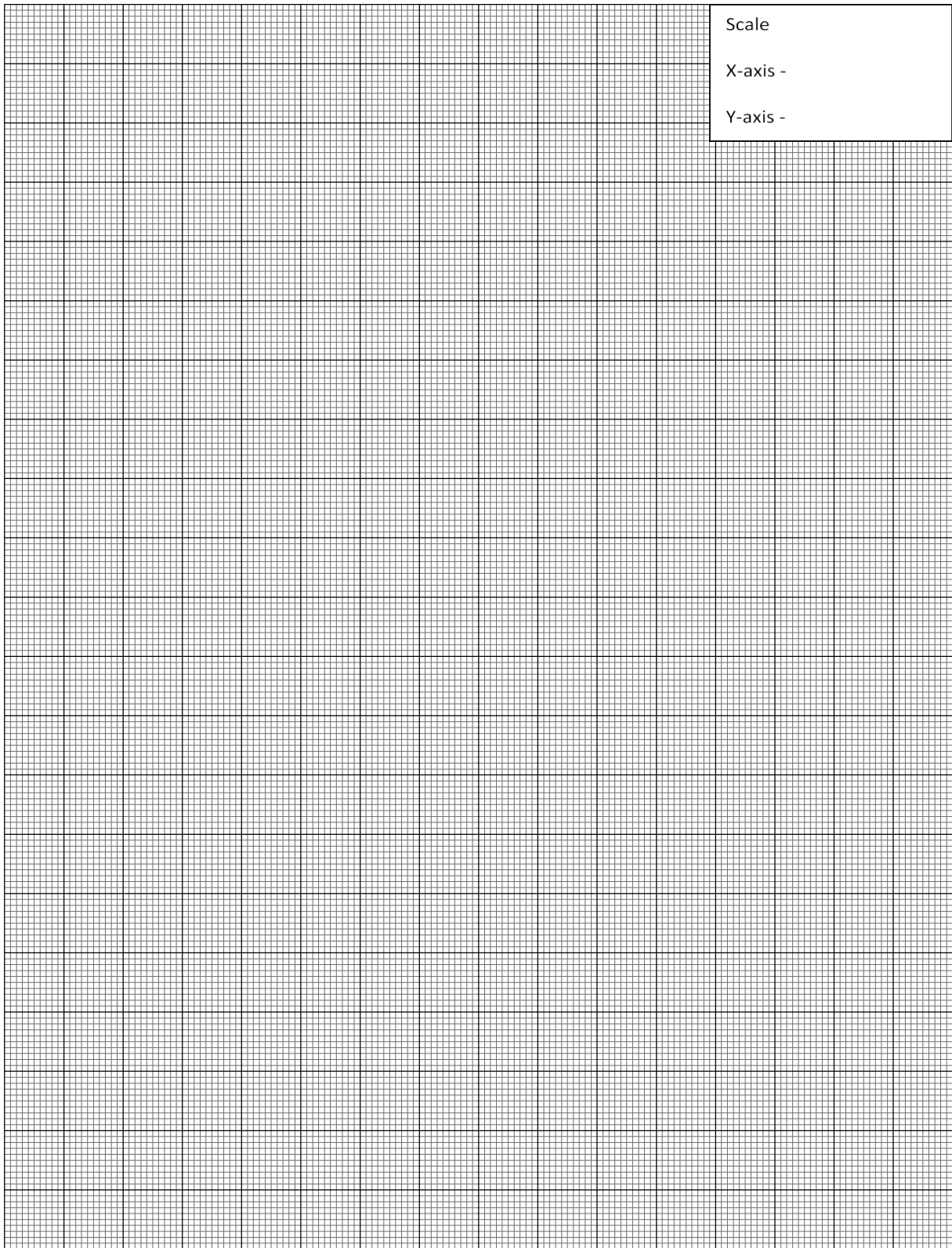

## **Practical No. 4-A: Determine mechanical advantage and velocity ratio of single purchase crab winch for different load and effort.**

### **I. Practical Significance**

There is often a need to lift loads and different lifting machines are used depending on the type of load, intensity of the load and other site conditions. The single purchase crab machine is used for lifting heavy loads in confined spaces. After carrying out this experiment, a qualified engineer can decide on the suitability of a single purchase crab based on the given lifting situation.

### **II. Industry/Employer Expected Outcomes**

Apply the principles of engineering mechanics to analyze, design and automation the prototypes and equipment's of various industries.

### **III. Course Level Learning Outcome(s)**

CO1-Select the suitable machine under given loading condition.

### **IV. Laboratory Learning Outcome(s)**

Verify law of machine under the given condition.

### **V. Relevant Affective Domain related Outcome(s)**

- a. Follow safety practices and precautions.
- b. Demonstrate working as a leader/a team member.
- c. Maintain tools and equipment.

### **VI. Relevant Theoretical Background**

**Single Purchase Crab:** Crab and winch are machines used for hoisting heavy loads applying smaller amount of effort. These machines use gear systems in order to augment velocity ratio. Depending on the number of gear assemblies, crab and winch systems can be classified into two types single and double purchase crab.

In single purchase crab, one set of gears, one pinion of teeth  $T_1$  and one spur wheel of teeth  $T_2$  are deployed. The pinion is fixed coaxially with the effort axle and effort pulley. Generally, a rope is wound around the effort wheel of diameter  $D$  through effort is applied. Effort then moves the pinion and thereby the spur wheel gets rotated. As the spur wheel is mounted coaxially with the load drum of diameter  $d$ , the load drum will get rotated. A strong rope is attached with load drum, at the end of which load is connected. Thus, the load is lifted by the rotation of the effort wheel. For a single rotation of effort wheel, distance travelled by effort =  $\pi D$ . For single rotation of pinion, spur wheel and thereby the load drum rotate =  $T_1/T_2$  times. So, displacement of load =  $\pi d \times (T_1/T_2)$

$$\text{Hence, Velocity Ratio (V. R.)} = \frac{D \times T_2}{d \times T_1}$$

Where,

$D$  = Diameter of effort wheel

$d$  = Diameter of load drum

$T_1$  = No. of teeth on the pinion wheel

$T_2$  = No. of thread on spur wheel.

**VII. Actual diagram used in laboratory with equipment specifications.**

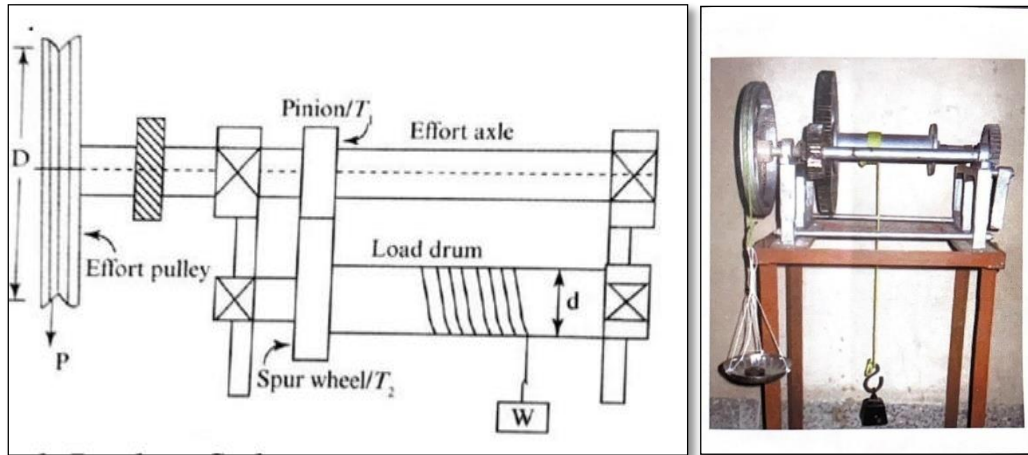

**Fig.4A.1 Single Purchase Crab**

**VIII. Requires Recourses/Apparatus/Equipment with Specifications**

Sr. No.	Broad Specifications	Quantity	Remarks (If Any)
1	Single Purchase Crab	Single Purchase Crab winch (Table mounted heavy Cast iron body. The effort wheel is of C.I. material of 25 cm diameter mounted on a shaft of about 40 mm dia. On the same shaft a geared wheel of 15 cm diameter.	01 for Group of 4 to 5 students.

**IX. Precautions to be followed**

1. Effort should not be pulled suddenly.
2. Friction in pulley should be less.
3. String should not be extensible and weightless.
4. Any overlapping of the string should be avoided.
5. Lubricate the screw before starting the experiment.
6. Trapping should be done after adding the weight in the effort hanger.

**X. Procedure**

1. Observe the machine carefully and identify the various components of machine.
2. Set the machine and check the reversibility of machine. Also calculate friction in machine at zero load
3. Apply the load starting with smaller magnitude.
4. Apply the effort for each corresponding load.
5. Record the observations of load and effort in observation table. Take at least five readings.
6. Measure the radius of effort wheel and load drum. Count number of teeth on pinion-gear and spur wheel.
7. Determine M.A., V.R., Efficiency, Ideal effort and Effort lost in friction for given Single Purchase Crab.

8. Plot graphs load against effort and load against efficiency.

**Observations and Calculations**

$$V. R. = \frac{D \times T_2}{d \times T_1} =$$

1. D = ..... mm
2. d = ..... mm
3. T<sub>1</sub> = ..... No.
4. T<sub>2</sub> = ..... No.

**XI. Observations Table**

Sr. No.	Load W (N)	Effort P (N)	M.A.	Velocity Ratio	Efficiency η (%)	Ideal Effort P <sub>i</sub> (N)	Effort Lost in Friction P <sub>f</sub> (N)
1							
2							
3							
4							
5							

**Sample Calculations**

$$M. A. = \frac{\text{Load}}{\text{Effort}} = \frac{W}{P} =$$

$$\text{Efficiency } (\eta) = \frac{M. A.}{V. R.} \times 100\% =$$

$$P_i = \frac{W}{V. R.} =$$

$$P_f = P - P_i =$$

Law of Machine is  $P = mW + C$

Where,

$$M = \text{Slope} = \frac{P_2 - P_1}{W_2 - W_1} =$$

$$C = \text{Y intercept (i.e. Machine Friction)} = \text{_____ N}$$





**XVI. References/Suggestions for further Reading**

Sr. No.	Link	Description
1	<a href="https://www.engineersrail.com/simple-lifting-machine/">https://www.engineersrail.com/simple-lifting-machine/</a>	Introduction of simple lifting machine
2	<a href="https://www.youtube.com/watch?v=kNypk8GReqM">https://www.youtube.com/watch?v=kNypk8GReqM</a>	Law of machine and types of machines useful in industry.
3	<a href="https://www.google.co.in/imgre">https://www.google.co.in/imgre</a> Winch-Crab-Single-Purchase.jpg	Single purchase crab winch image
4	<a href="http://nitttrc.edu.in/nptel/courses/video/112106286/L01.html">http://nitttrc.edu.in/nptel/courses/video/112106286/L01.html</a>	Introduction to engineering mechanics

**XVII. Suggested Assessment Scheme**

Performance Indicators		Weightage (%)
<b>Process related: 15 Marks</b>		<b>60 %</b>
1	Handling of the machine.	5 %
2	Determination of V. R. of machine.	10 %
3	Applying load and determine effort of machine.	20 %
4	Identify the type of machine i.e. reversible or self-locking.	10 %
5	Calculation of parameters concerned.	10 %
6	Working in team.	5 %
<b>Product related: 10 Marks</b>		<b>40 %</b>
1	Error estimation.	5 %
2	Interpretation of result and graph.	10 %
3	Conclusion and Recommendation.	10 %
4	Answer to the practical related questions.	10 %
5	Submission of report in time.	5 %
<b>Total: 25 Marks</b>		<b>100 %</b>

Marks Obtained			Dated sign of Teacher
Process Related(15)	Product Related(10)	Total(25)	

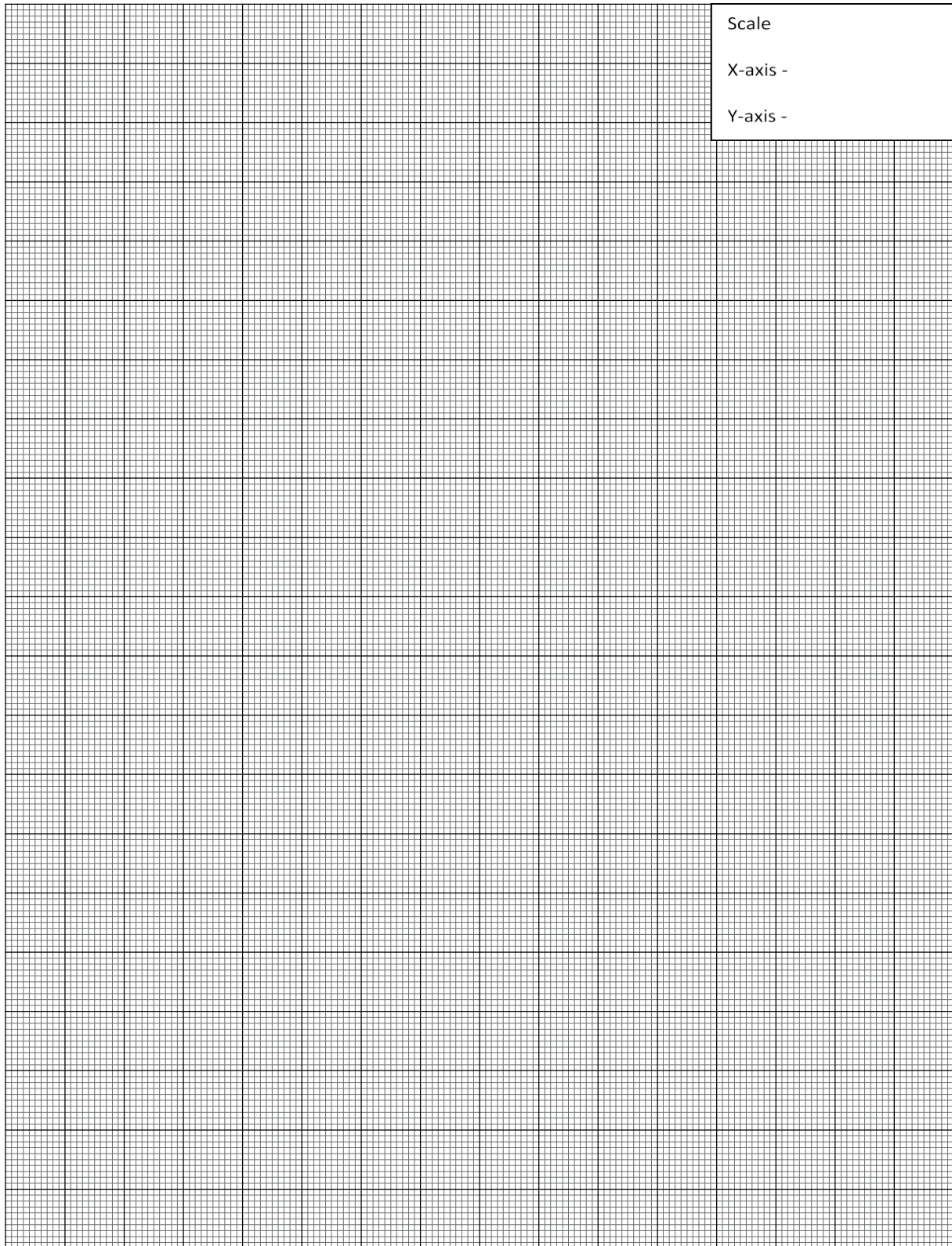

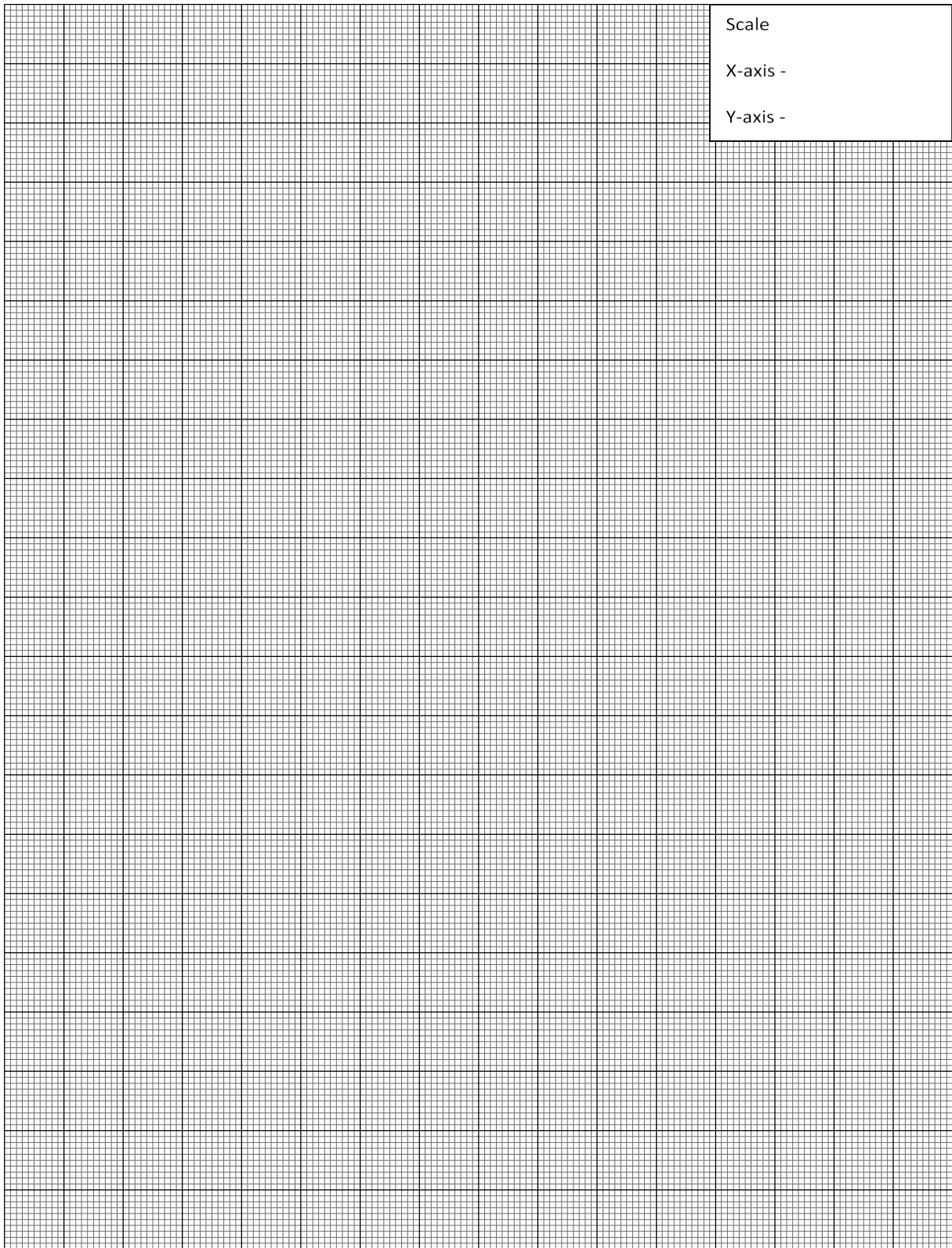

## **Practical No. 4-B: Determine mechanical advantage and velocity ratio of Double purchase crab winch for different load and effort.**

### **I. Practical Significance**

There is often a need to lift loads and different lifting machines are used depending on the type of load, intensity of the load and other site conditions. The Double Purchase Crab machine is used for lifting heavy loads in confined spaces. According to per. Through this experiment, a qualified engineer can decide on the suitability of a double purchase crab based on the given lifting situation.

### **II. Industry/Employer Expected Outcomes**

Apply the principles of engineering mechanics to analyze, design and automation the prototypes and equipment's of various industries

### **III. Course Level Learning Outcome(s)**

CO1-Select the suitable machine under given loading condition.

### **IV. Laboratory Learning Outcome(s)**

Verify law of machine under the given condition.

### **V. Relevant Affective Domain related Outcome(s)**

- a. Follow safety practices and precautions.
- b. Demonstrate working as a leader/a team member.
- c. Maintain tools and equipment.

### **VI. Relevant Theoretical Background**

**Double Purchase Crab:** Crab and winch are machines used for hoisting heavy loads applying smaller amount of effort. These machines use gear systems in order to augment velocity ratio. Depending on the number of gear assemblies, crab and winch systems can be classified into two types single and double purchase crab.

In double purchase crab machine, two sets of gear assemblies are used. One additional axle, called an intermediate axle, is deployed. The pinion of teeth  $T_1$ , mounted on effort wheel axle meshes with spur wheel of teeth  $T_2$ , mounted on the intermediate axel.

Similarly, the pinion of teeth  $T_3$ , on intermediate axle meshes with spur wheel of teeth  $T_4$ , mounted on the load drum. A rope is wound around the effort wheel of diameter  $D$  through effort is applied and load is attached to another rope wound around the load drum. Effort then moves the pinion and thereby the spur wheel gets rotated. As the spur wheel is mounted intermediate axle it gets rotated. As intermediate axle rotates the load drum of diameter  $d$ , will get rotated. A strong rope is attached with load drum, at the end of which load is connected. Thus, the load is lifted by the rotation of the effort wheel.

For a single rotation of the effort wheel, distance travelled by effort =  $\pi D$ . For single rotation of pinion, on effort axle, spur wheel on intermediate axle rotates =  $T_1/T_2$  times. Now the pinion on the intermediate axle also rotates =  $T_1/T_2$  times. So, the spur wheel of the load drum rotates =  $(T_1/T_2) \times (T_3/T_4)$  times. Thus, the displacement of load =  $\pi d \times (T_1/T_2) \times (T_3/T_4)$

$$\text{Hence, Velocity Ratio (V.R.)} = \frac{\pi D}{\pi d \left(\frac{T_1}{T_2}\right)\left(\frac{T_3}{T_4}\right)} = \frac{D \times T_2 \times T_4}{d \times T_1 \times T_3}$$

Where,

D = Diameter of effort wheel

d = Diameter of load drum

T<sub>1</sub> and T<sub>3</sub> = No. of teeth on the pinion wheel

T<sub>2</sub> and T<sub>4</sub> = No. of thread on spur wheel.

**VII. Actual diagram used in laboratory with equipment specifications.**

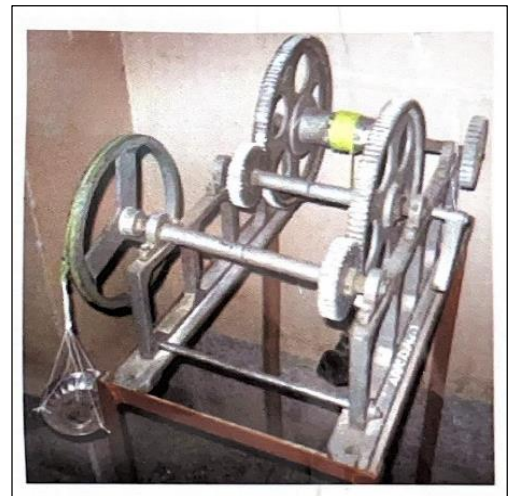
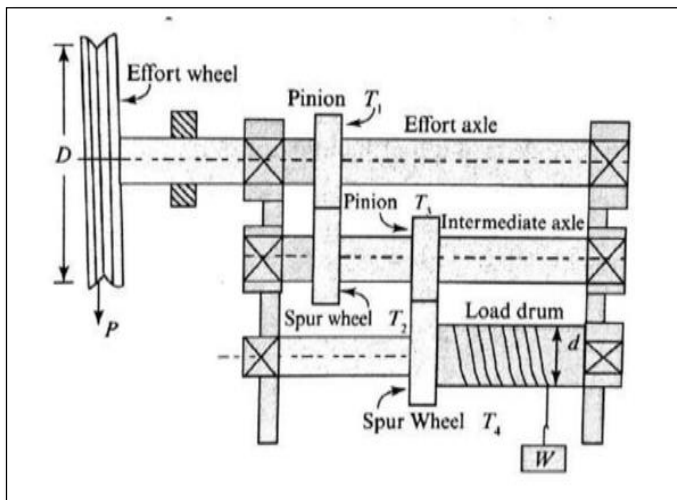

**Fig. 4B.1 Double Purchase Crab**

**VIII. Requires Recourses/Apparatus/Equipment with Specifications**

Sr. No.	Particulars	Broad Specifications	Quantity	Remarks (If Any)
1	Double Purchase Crab	Double Purchase Crab winch (Having assembly same as single purchase crab but with double set gearing arrangement)	01 for Group of 4 to 5 students.	

**IX. Precautions to be followed**

1. Effort should not be pulled suddenly.
2. Friction in pulley should be less.
3. String should not be extensible and weightless.
4. Any overlapping of the string should be avoided.
5. Lubricate the screw before starting the experiment.
6. Trapping should be done after adding the weight in the effort hanger.

**X. Procedure**

1. Observe the machine carefully and identify the various components of machine.

2. Set the machine and check the reversibility of machine.
3. Calculate friction in the machine based on zero load.
4. Apply the load starting with smaller magnitude.
5. Apply the effort for each corresponding load.
6. Record the observations of load and effort in observation table. Take at least five readings.
7. Measure the radius of effort wheel and load drum. Count number of teeth on pinion gear and spur wheels.
8. Determine M.A., V.R., Efficiency, Ideal effort and Effort lost in friction for given Double Purchase Crab.
9. Plot graphs viz. load against effort and load against efficiency

**Observations and Calculations**

$$\text{Velocity Ratio} = \frac{D \times T_2 \times T_4}{d \times T_1 \times T_3}$$

1. D = ..... mm
2. d = ..... mm
3. T<sub>1</sub> = ..... No.
4. T<sub>2</sub> = ..... No.
5. T<sub>3</sub> = ..... No
6. T<sub>4</sub> = ..... No

**XI. Observations Table**

Sr. No.	Load W (N)	Effort P (N)	M.A.	Velocity Ratio	Efficiency η (%)	Ideal Effort P <sub>i</sub> (N)	Effort Lost in Friction P <sub>f</sub> (N)
1							
2							
3							
4							
5							

**Sample Calculations**

$$M.A. = \frac{\text{Load}}{\text{Effort}} = \frac{W}{P} =$$

$$\text{Efficiency } (\eta) = \frac{M.A.}{V.R.} \times 100\% =$$

$$P_i = \frac{W}{V.R.} =$$

$$P_f = P - P_i =$$

Law of Machine is  $P = mW + C$

Where,

$$M = \text{Slope} = \frac{P_2 - P_1}{W_2 - W_1} =$$

$C = Y \text{ intercept (i.e. Machine Friction)} = \text{_____} N$

**XII. Results**

1. The law of machine is  $P = (\text{.....}) W + (\text{.....}) N$
2. The average efficiency of machine is = ..... %

**XIII. Interpretation of results**

Machine is .....

Friction loss is (i.e. Y – intercept = ..... ) reduced by ..... the machine.

The graph between load and effort is a straight line which indicates.....

The graph between load and efficiency is a curve which indicates.....

**XIV. Conclusions and Recommendations**

.....  
.....  
.....

**XV. Practical Related Questions**

Note: Below given are few sample questions for reference. Teachers must design more such questions so as to ensure the achievement of identified CO. Write answers of minimum three questions.

1. Calculate the effort required to lift a load of 50 kn from the graph of load against effort.
2. State any two field conditions where this machine can be used.
3. State the difference between single purchase crab and double purchase crab.
4. Describe the law of double purchase crab machine.
5. State, single or double purchase crab machine is preferred at construction site. Give reason.

**Space for answers**

.....  
.....  
.....  
.....  
.....  
.....  
.....  
.....  
.....  
.....



**XVII. Suggested Assessment Scheme**

Performance Indicators		Weightage (%)
<b>Process related: 15 Marks</b>		<b>60 %</b>
1	Handling of the machine.	5 %
2	Determination of V. R. of machine.	10 %
3	Applying load and determine effort of machine.	20 %
4	Identify the type of machine i.e. reversible or self-locking.	10 %
5	Calculation of parameters concerned.	10 %
6	Working in team.	5 %
<b>Product related: 10 Marks</b>		<b>40 %</b>
1	Error estimation.	5 %
2	Interpretation of result and graph.	10 %
3	Conclusion and Recommendation.	10 %
4	Answer to the practical related questions.	10 %
5	Submission of report in time.	5 %
<b>Total: 25 Marks</b>		<b>100 %</b>

Marks Obtained			Dated sign of Teacher
Process Related(15)	Product Related(10)	Total(25)	

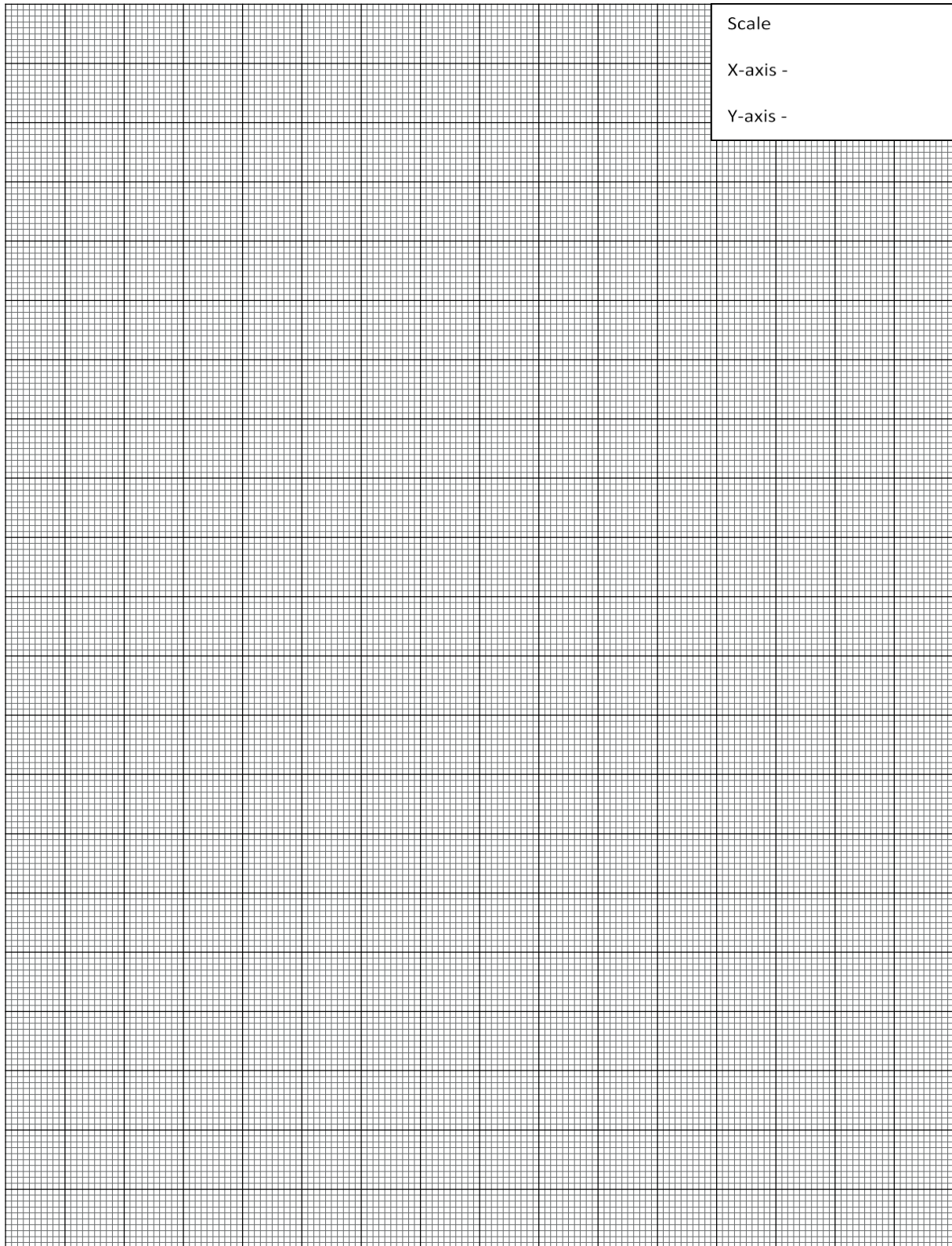

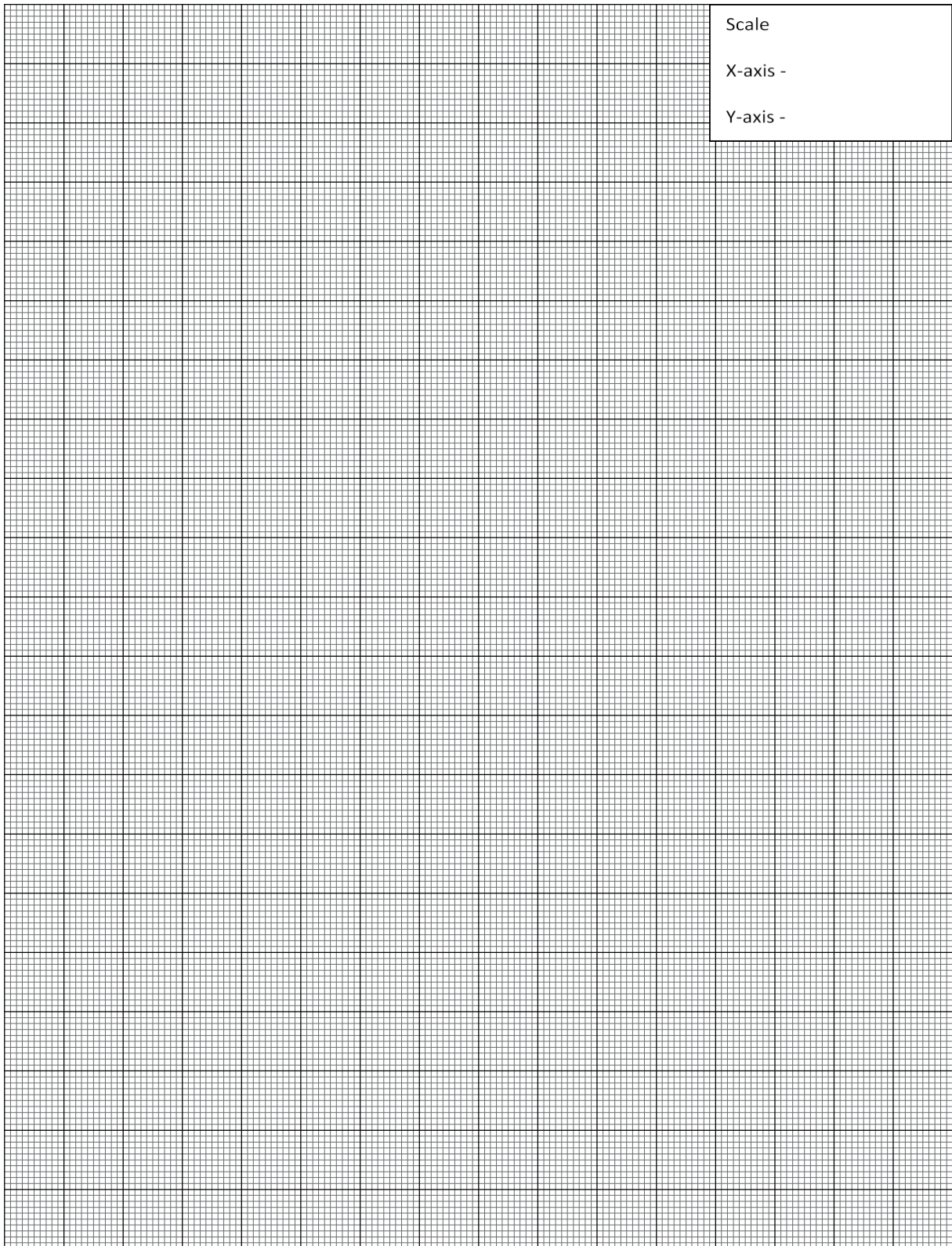

**Practical No. 5: Determine mechanical advantage and velocity ratio of Simple screw jack for different load and effort.**

**I. Practical Significance**

There is often a need to lift loads and different lifting machines are used depending on the type of load, intensity of the load and other site conditions. A simple screw jack is used to lift heavy loads in confined spaces. After carrying out this experiment, a qualified engineer is able to assess the suitability of a screw jack based on the given load lifting situation.

**II. Industry/Employer Expected Outcomes**

Apply the principles of engineering mechanics to analyze, design and automation the prototypes and equipment's of various industries

**III. Course Level Learning Outcome(s)**

CO1-Select the suitable machine under given loading condition.

**IV. Laboratory Learning Outcome(s)**

Verify law of machine under the given condition.

**V. Relevant Affective Domain related Outcome(s)**

- a. Follow safety practices and precautions.
- b. Demonstrate working as a leader/a team member.
- c. Maintain tools and equipment.

**VI. Relevant Theoretical Background**

**Simple Screw Jack:** A screw jack is a simple device which is used to lift heavy loads such as large vehicles. It mainly consists of three parts. A nut attached to a pedestal or stand, a large screw fitted within the nut and lever attached to the head of the screw.

The weight which is to be lifted is placed on either on the head of the screw or on the platform attached to the screw. Sometimes a wheel is fixed at top and effort is applied tangentially to the circumference of the wheel. A screw thread is cut just like an inclined plane. The distance which the screw advances in one turn is called lead distance and distance measured between two consecutive threads is called pitch distance. The screw jack works on the principle similar to that of an inclined plane.

$$\text{Velocity Ratio (V. R.)} = \frac{2\pi R}{p}$$

Where,

R = Length of arm or Radius of wheel

p = Pitch of the screw

**VII. Actual diagram used in laboratory with equipment specifications.**

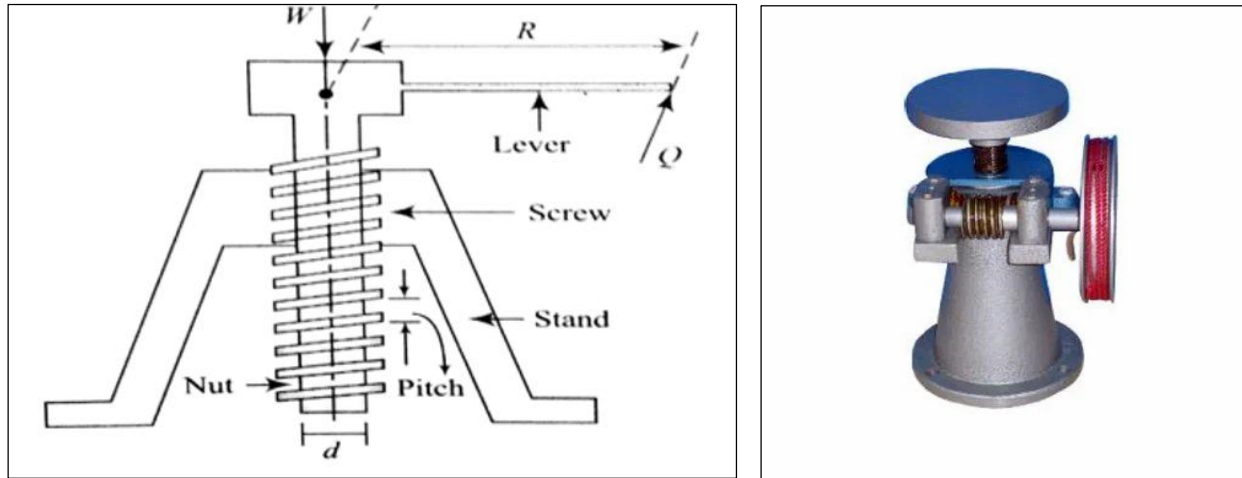

**Fig. 5.1 Simple Screw Jack**

**VIII. Requires Recourses/Apparatus/Equipment with Specifications**

Sr. No.	Particulars	Broad Specifications	Quantity	Remarks (If Any)
1	Simple Screw Jack	Table mounted Metallic body, screw with a pitch of 5 mm carrying a double flanged tum table of 20 cm diameter.	01 for Group of 4 to 5 students.	

**IX. Precautions to be followed**

1. Effort must be applied gradually

**X. Procedure**

1. Observe the machine carefully and identify the various components of machine.
2. Set the machine and check the reversibility of machine
3. Calculate friction in the machine at zero load.
4. Apply the load starting with smaller magnitude.
5. Apply the effort for each corresponding load.
6. Record the observations of load and effort in observation table. Take at least five readings.
7. Determine M.A., V.R., Efficiency, Ideal effort and Effort lost in friction for given screw jack.
8. Plot graphs load against effort and load against efficiency.

**Observations and Calculations**

$$V. R. = \frac{2\pi R}{p}$$

1. R = ..... mm
2. p = ..... mm

**XI. Observations Table**

Sr. No.	Load W (N)	Effort P (N)	M.A.	Velocity Ratio	Efficiency $\eta$ (%)	Ideal Effort $P_i$ (N)	Effort Lost in Friction $P_f$ (N)
1							
2							
3							
4							
5							

**Sample Calculations**

$$M.A. = \frac{\text{Load}}{\text{Effort}} = \frac{W}{P} =$$

$$\text{Efficiency } (\eta) = \frac{M.A.}{V.R.} \times 100\% =$$

$$P_i = \frac{W}{V.R.} =$$

$$P_f = P - P_i =$$

Law of Machine is  $P = mW + C$

Where,

$$M = \text{Slope} = \frac{P_2 - P_1}{W_2 - W_1} =$$

$C = Y$  intercept (i.e. Machine Friction) = \_\_\_\_\_ N

**XII. Results**

1. The law of machine is  $P = (\dots\dots\dots) W + (\dots\dots\dots) N$
2. The average efficiency of machine is = ..... %

**XIII. Interpretation of results**

Machine is .....

Friction loss is (i.e.  $Y -$  intercept = .....) reduced by ..... the machine.

The graph between load and effort is a straight line which indicates.....

The graph between load and efficiency is a curve which indicates.....

.....

**XIV. Conclusions and Recommendations**

.....  
 .....  
 .....





**XVII. Suggested Assessment Scheme**

Performance Indicators		Weightage (%)
<b>Process related: 15 Marks</b>		<b>60 %</b>
1	Handling of the machine.	5 %
2	Determination of V. R. of machine.	10 %
3	Applying load and determine effort of machine.	20 %
4	Identify the type of machine i.e. reversible or self-locking.	10 %
5	Calculation of parameters concerned.	10 %
6	Working in team.	5 %
<b>Product related: 10 Marks</b>		<b>40 %</b>
1	Error estimation.	5 %
2	Interpretation of result and graph.	10 %
3	Conclusion and Recommendation.	10 %
4	Answer to the practical related questions.	10 %
5	Submission of report in time.	5 %
<b>Total: 25 Marks</b>		<b>100 %</b>

Marks Obtained			Dated sign of Teacher
Process Related(15)	Product Related(10)	Total(25)	

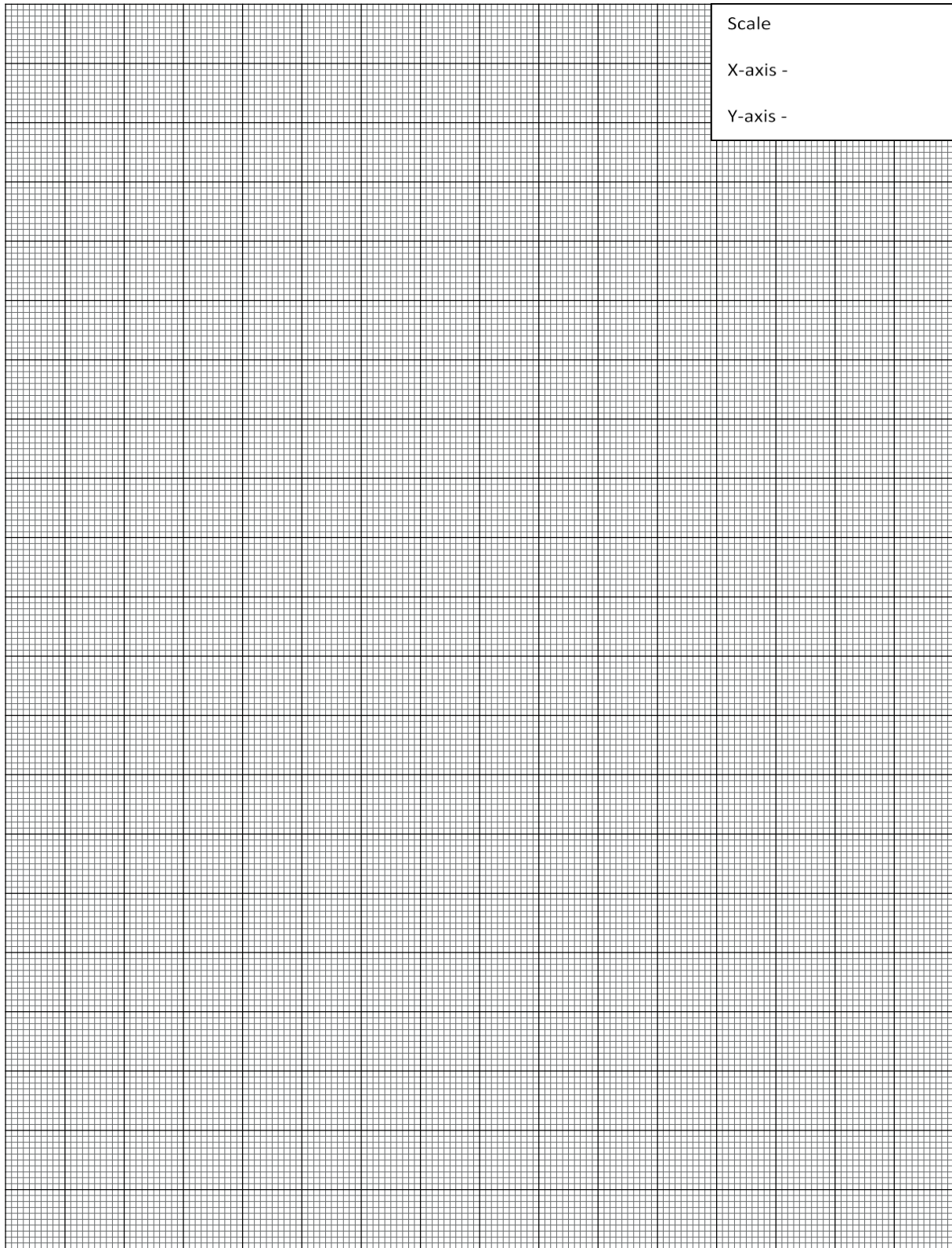

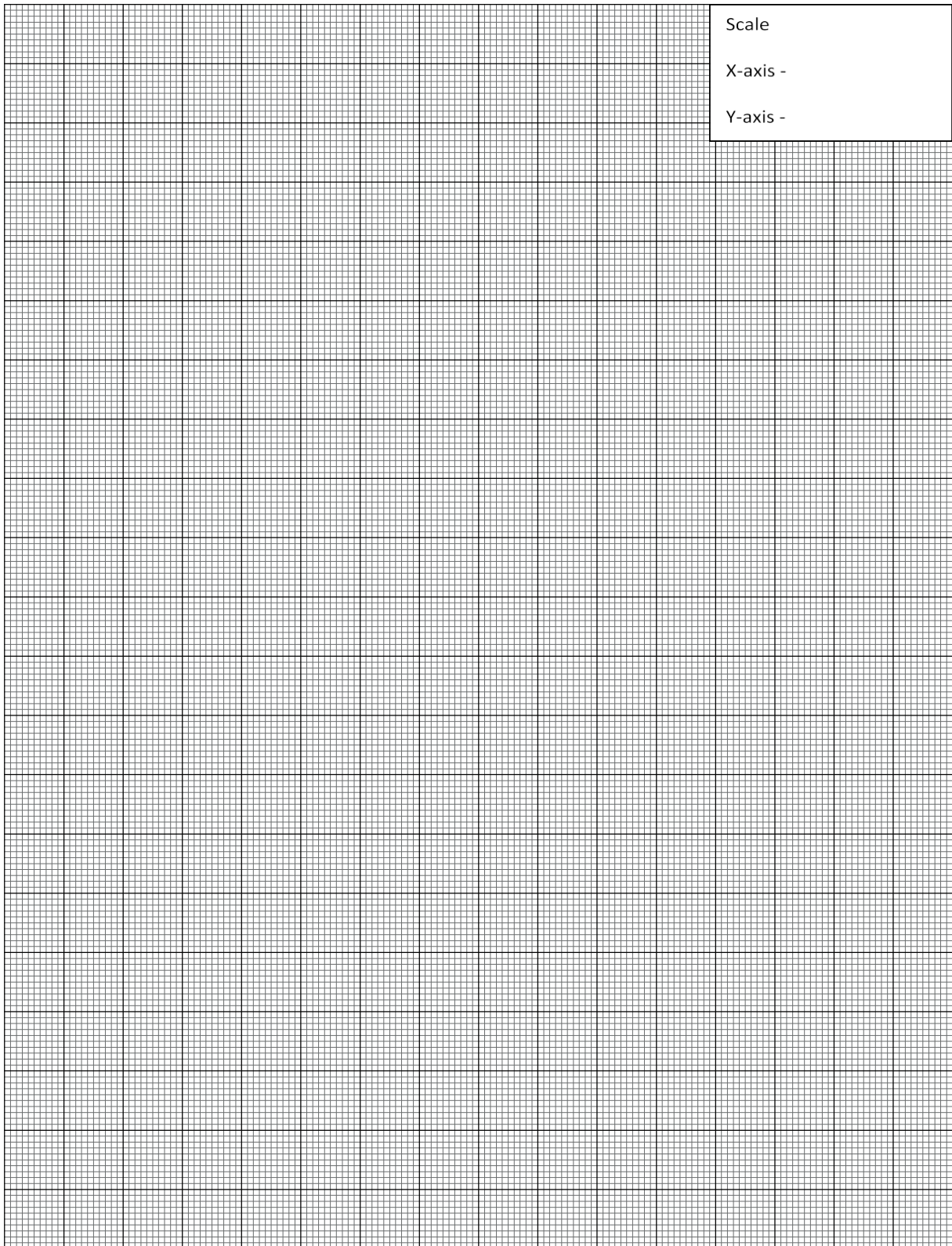

## **Practical No. 6: Determine mechanical advantage and velocity ratio of Weston's differential pulley for different load and effort.**

### **I. Practical Significance**

There is often a need to lift loads and different lifting machines are used depending on the type of load, intensity of the load and other site conditions. Weston's differential pulley block is used for lifting heavy loads in confined spaces. After conducting this experiment, a graduate engineer can evaluate the suitability of the Weston differential pulley block based on the given load lifting situation.

### **II. Industry/Employer Expected Outcomes**

Apply the principles of engineering mechanics to analyze, design and automation the prototypes and equipment's of various industries

### **III. Course Level Learning Outcome(s)**

CO1-Select the suitable machine under given loading condition.

### **IV. Laboratory Learning Outcome(s)**

Verify law of machine under the given condition.

### **V. Relevant Affective Domain related Outcome(s)**

- a. Follow safety practices and precautions.
- b. Demonstrate working as a leader/a team member.
- c. Maintain tools and equipment.

### **VI. Relevant Theoretical Background**

**Weston's Differential Pulley Block:** This differential pulley block was invented by Thomas Aldridge Weston from king's Norton, England, in 1854. Hence, this simple machine is also called as Weston's differential pulley block. This is a special type of pulley system, which is normally used to hoist very large masses to small distance, for example, the pulley system is used for manually lifting car engines. This system consists of two fixed pulleys of unequal radii, which are coaxially attached to each other and can rotate together and are fixed to the support, a single pulley hanging at the bottom and holding load and an endless rope wrapped around the pulleys. In order to avoid slipping, generally rope is substituted by a chain and connected to pulleys by sprockets (i.e. tooth or cogs on pulleys). The displacement of the effort in one revolution of upper pulley block =  $\pi D$ . This is also equal to length of the chain pulled over the large pulley. Since the smaller pulley also turns with the larger one, therefore length of the chain released by the smaller pulley =  $\pi d$ . Net shortening of the chain =  $\pi D - \pi d = \pi (D-d)$ . This shortening of chain will be equally divided between the portion of the chain, supporting the load. Therefore, the distance the load moves up by a distance  $\pi (D-d)/2$ .

$$\begin{aligned} \text{Velocity Ratio (V. R.)} &= \frac{2D}{D-d} \\ &= \frac{2T_1}{T_1 - T_2} \end{aligned}$$

Where,

1.  $D$  = Diameter of pulley  $P_1$
2.  $d$  = Diameter of pulley  $P_2$
3.  $T_1$  = No. of teeth or cogs of pulley  $P_1$
4.  $T_2$  = No. of teeth or cogs on pulley  $P_2$

**VII. Actual diagram used in laboratory with equipment specifications.**

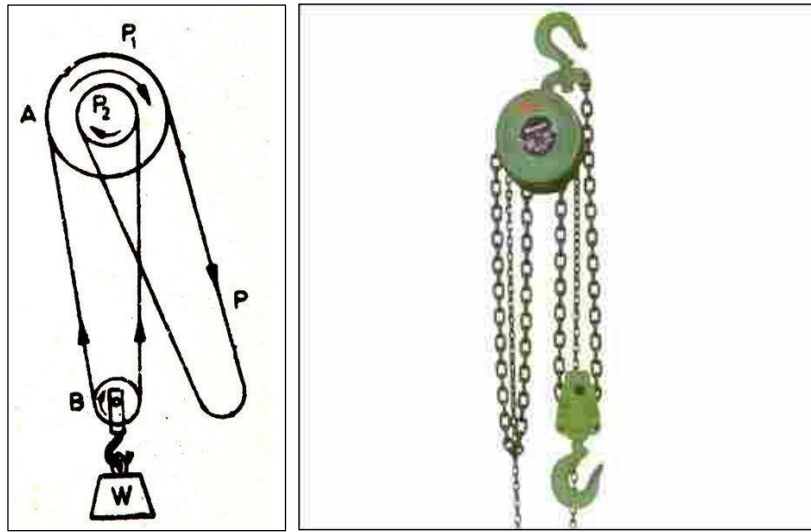

**Fig. 6.1 Weston's Differential Pulley Block**

**VIII. Requires Recourses/Apparatus/Equipment with Specifications**

Sr. No.	Particulars	Broad Specifications	Quantity	Remarks (If Any)
1	Weston's Differential Pulley Block	Weston's Differential pulley block (consisting of two pulleys; one bigger and other smaller)	01 for Group of 4 to 5 students.	

**IX. Precautions to be followed**

1. Effort must be applied gradually

**X. Procedure**

1. Observe the machine carefully and identify the various components of machine.
2. Set the machine and check the reversibility of it.
3. Calculate friction in the given machine at zero load.
4. Apply the load starting with smaller magnitude.
5. Apply the effort for each corresponding load.
6. Record the observations of load and effort in observation table. Take at least five readings.

7. Measure the radius or number of cogs of larger and smaller pulley.
8. Determine M.A., V.R., Efficiency, Ideal effort and Effort lost in friction for given Weston's Differential pulley block.
9. Plot graphs viz. load against effort and load against efficiency.

**Observations and Calculations**

$$V. R. = \frac{2D}{D - d} = \frac{2T_1}{T_1 - T_2}$$

1.  $T_1 = \dots\dots\dots$  No.
2.  $T_2 = \dots\dots\dots$  No.

**XI. Observations Table**

Sr. No.	Load W (N)	Effort P (N)	M.A.	Velocity Ratio	Efficiency $\eta$ (%)	Ideal Effort $P_i$ (N)	Effort Lost in Friction $P_f$ (N)
1							
2							
3							
4							
5							

**Sample Calculations**

$$M. A. = \frac{\text{Load}}{\text{Effort}} = \frac{W}{P} =$$

$$\text{Efficiency } (\eta) = \frac{M. A.}{V. R.} \times 100\% =$$

$$P_i = \frac{W}{V.R.} =$$

$$P_f = P - P_i =$$

Law of Machine is  $P = mW + C$

Where,

$$M = \text{Slope} = \frac{P_2 - P_1}{W_2 - W_1} =$$

$$C = \text{Y intercept (i.e. Machine Friction)} = \text{_____} \text{N}$$

**XII. Results**

1. The law of machine is  $P = (\dots\dots\dots) W + (\dots\dots\dots) N$





**XVII. Suggested Assessment Scheme**

<b>Performance Indicators</b>		<b>Weightage (%)</b>
<b>Process related: 15 Marks</b>		<b>60 %</b>
1	Handling of the machine.	5 %
2	Determination of V. R. of machine.	10 %
3	Applying load and determine effort of machine.	20 %
4	Identify the type of machine i.e. reversible or self-locking.	10 %
5	Calculation of parameters concerned.	10 %
6	Working in team.	5 %
<b>Product related: 10 Marks</b>		<b>40 %</b>
1	Error estimation.	5 %
2	Interpretation of result and graph.	10 %
3	Conclusion and Recommendation.	10 %
4	Answer to the practical related questions.	10 %
5	Submission of report in time.	5 %
<b>Total: 25 Marks</b>		<b>100 %</b>

<b>Marks Obtained</b>			<b>Dated sign of Teacher</b>
<b>Process Related(15)</b>	<b>Product Related(10)</b>	<b>Total(25)</b>	



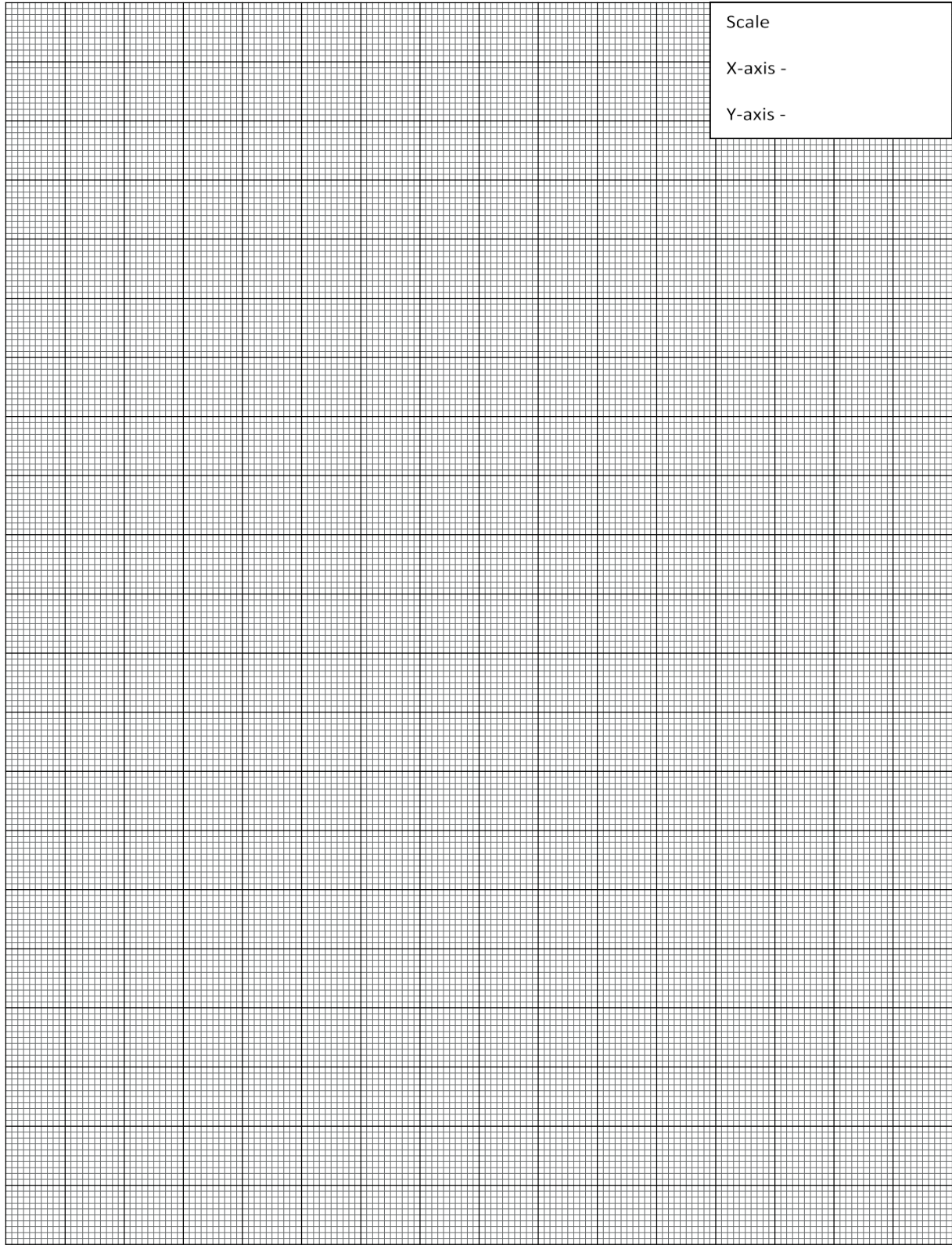

## **Practical No. 7: Determine mechanical advantage and velocity ratio of geared pulley block for different load and effort.**

### **I. Practical Significance**

There is often a need to lift loads and different lifting machines are used depending on the type of load, intensity of the load and other site conditions. The gear pulley is used for lifting heavy loads in confined spaces. After conducting this experiment, a graduate engineer can assess the suitability of the Geard pulley based on the given load lifting situation.

### **II. Industry/Employer Expected Outcomes**

Apply the principles of engineering mechanics to analyze, design and automation the prototypes and equipment's of various industries

### **III. Course Level Learning Outcome(s)**

CO1-Select the suitable machine under given loading condition.

### **IV. Laboratory Learning Outcome(s)**

Verify law of machine under the given condition.

### **V. Relevant Affective Domain related Outcome(s)**

- a. Follow safety practices and precautions.
- b. Demonstrate working as a leader/a team member.
- c. Maintain tools and equipment.

### **VI. Relevant Theoretical Background**

**Worm Gear Pulley Block:** In a gear pulley block, an axle is coaxially attached to an effort wheel having  $T_1$  number teeth. A pinion having teeth  $T_2$  and a ratchet and clutch are attached coaxially on the axle. A pawl presses against this ratchet and clutch with the help of a spring. The pinion is geared with a spur wheel having teeth  $T_3$ . On the same axle as spur wheel a load drum having teeth  $T_4$  is keyed on its circumference. An endless rope or chain is wound over effort wheel with which the effort is applied. The motion is transmitted from effort wheel to load drum through pinion and spur wheel. A separate rope is wound around half the perimeter of load drum. One end of it is fixed to the frame and other end holds the load. When the load is hoisted, the ratchet passes under the pawl. On the removal of effort, the pawl prevents the load from falling down. Hence, it is self-locking arrangement. In single rotation of effort wheel, effort moves through a distance proportional to  $T_1$ . At the same time, the spur wheel and the load drum rotate by  $(T_2/T_1)$  of a rotation. In single rotation of load drum, the load is lifted through distance proportional to 4. So far, a single rotation of effort wheel, the load is lifted by a distance  $(T_2/T_3) \times T_4$ .

Hence,

$$\text{Velocity Ratio (V. R.)} = \frac{T_1}{\frac{T_2}{T_3} - T_4} = \frac{T_1 \times T_3}{T_2 \times T_4}$$

Where,

$T_1$  = No. of teeth or cogs on effort wheel

$T_2$  = No. of teeth or cogs on pinion wheel

$T_3$  = No. of teeth or cogs on spur wheel

$T_4$  = No. of teeth or cogs on load drum

**VII. Actual diagram used in laboratory with equipment specifications.**

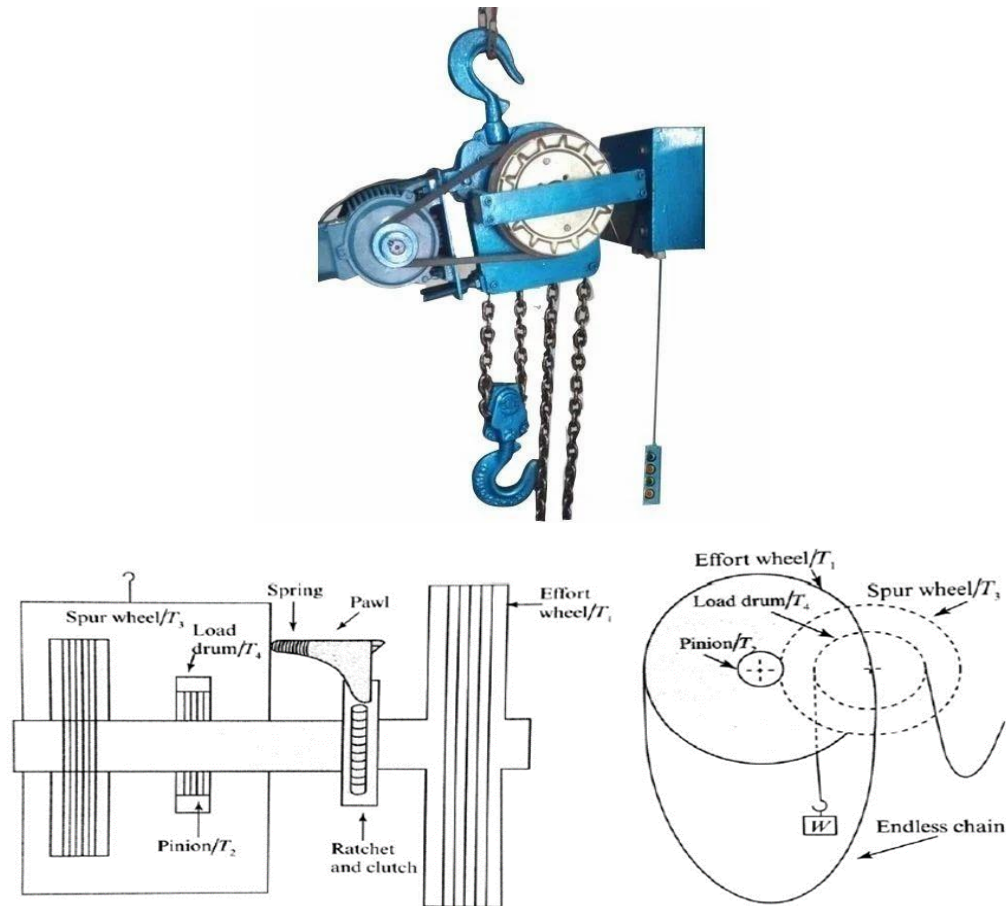

**Fig. 7.1 Worm Gear Pulley Block**

**VIII. Requires Recourses/Apparatus/Equipment with Specifications**

Sr. No.	Particulars	Broad Specifications	Quantity	Remarks (If Any)
1	Worm Gear Pulley Block.	Worm gear pulley block consists of a metallic (preferably steel) cogged wheel of about 20 cm along with a protruded load drum of 10 cm diameter to suspend the weights of 10 kg, 20 kg and 50 kg weights.	01 for Group of 4 to 5 students.	

**IX. Precautions to be followed**

1. Effort must be applied gradually

**X. Procedure**

1. Observe the machine carefully and identify the various components of machine.
2. Set the machine and check the reversibility of it.
3. Calculate friction in the given machine at zero load.
4. Apply the load starting with smaller magnitude.
5. Apply the effort for each corresponding load.
6. Record the observations of load and effort in observation table. Take at least five readings.
7. Measure the radius or number of cogs of larger and smaller pulley.
8. Determine M.A., V.R., Efficiency, Ideal effort and Effort lost in friction for given Weston's differential pulley block.
9. Plot graphs load against effort and load against efficiency.

**Observations and Calculations**

$$V. R. = \frac{T_1}{\frac{T_2}{T_3} - T_4} = \frac{T_1 \times T_3}{T_2 \times T_4}$$

1.  $T_1 = \dots\dots\dots$  No.
2.  $T_2 = \dots\dots\dots$  No.
3.  $T_3 = \dots\dots\dots$  No.
4.  $T_4 = \dots\dots\dots$  No.

**XI. Observations Table**

Sr. No.	Load W (N)	Effort P (N)	M.A.	Velocity Ratio	Efficiency $\eta$ (%)	Ideal Effort $P_i$ (N)	Effort Lost in Friction $P_f$ (N)
1							
2							
3							
4							
5							

**Sample Calculations**

$$M. A. = \frac{\text{Load}}{\text{Effort}} = \frac{W}{P} =$$

$$\text{Efficiency } (\eta) = \frac{M. A.}{V. R.} \times 100\% =$$

$$P_i = \frac{W}{V.R.} =$$

$$P_f = P - P_i =$$

Law of Machine is  $P = mW + C$

Where,

$$M = \text{Slope} = \frac{P_2 - P_1}{W_2 - W_1} =$$

C = Y intercept (i.e. Machine Friction) = \_\_\_\_\_ N

**XII. Results**

1. The law of machine is  $P = (\dots\dots\dots) W + (\dots\dots\dots) N$
2. The average efficiency of machine is = ..... %

**XIII. Interpretation of results**

Machine is .....

Friction loss is (i.e. Y – intercept = ..... ) reduced by ..... the machine.

The graph between load and effort is a straight line which indicates.....

The graph between load and efficiency is a curve which indicates.....

.....

**XIV. Conclusions and Recommendations**

.....  
.....  
.....

**XV. Practical Related Questions**

Note: Below given are few sample questions for reference. Teachers must design more such questions so as to ensure the achievement of identified CO. Write answers of minimum three questions.

1. Determine the effort required to lift a load of 200 kn from law of machine.
2. State the two situations in field where worm gear pulley block is used
3. Differentiate between differential and worm gear pulley block.
4. State is the capacity of chain block you have used?
5. State no. of chain used in differential pulley block and worm geared pulley block.

**Space for answers**

.....  
.....  
.....  
.....  
.....  
.....  
.....  
.....  
.....  
.....



**XVII. Suggested Assessment Scheme**

<b>Performance Indicators</b>		<b>Weightage (%)</b>
<b>Process related: 15 Marks</b>		<b>60 %</b>
1	Handling of the machine.	5 %
2	Determination of V. R. of machine.	10 %
3	Applying load and determine effort of machine.	20 %
4	Identify the type of machine i.e. reversible or self-locking.	10 %
5	Calculation of parameters concerned.	10 %
6	Working in team.	5 %
<b>Product related: 10 Marks</b>		<b>40 %</b>
1	Error estimation.	5 %
2	Interpretation of result and graph.	10 %
3	Conclusion and Recommendation.	10 %
4	Answer to the practical related questions.	10 %
5	Submission of report in time.	5 %
<b>Total: 25 Marks</b>		<b>100 %</b>

<b>Marks Obtained</b>			<b>Dated sign of Teacher</b>
<b>Process Related(15)</b>	<b>Product Related(10)</b>	<b>Total(25)</b>	

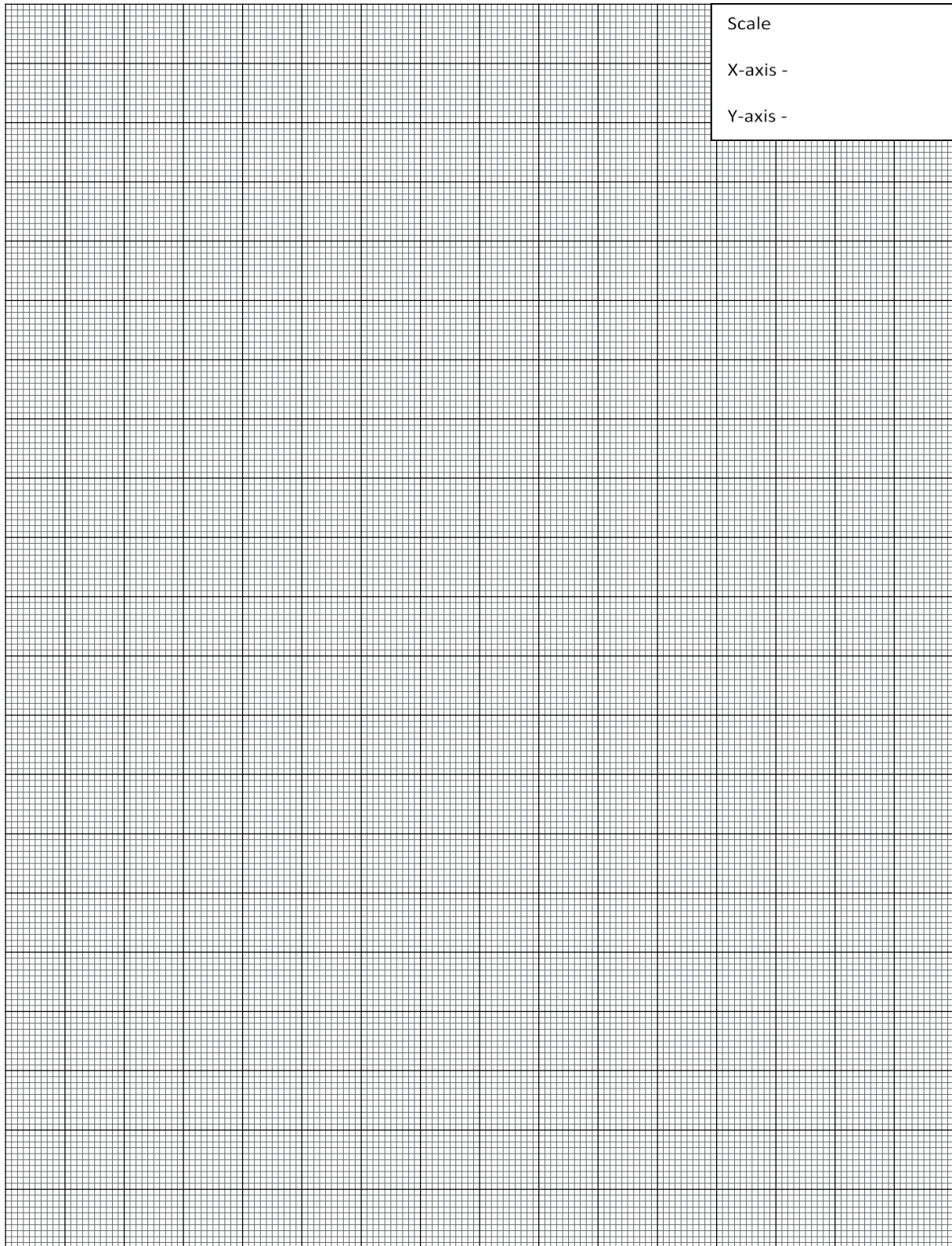

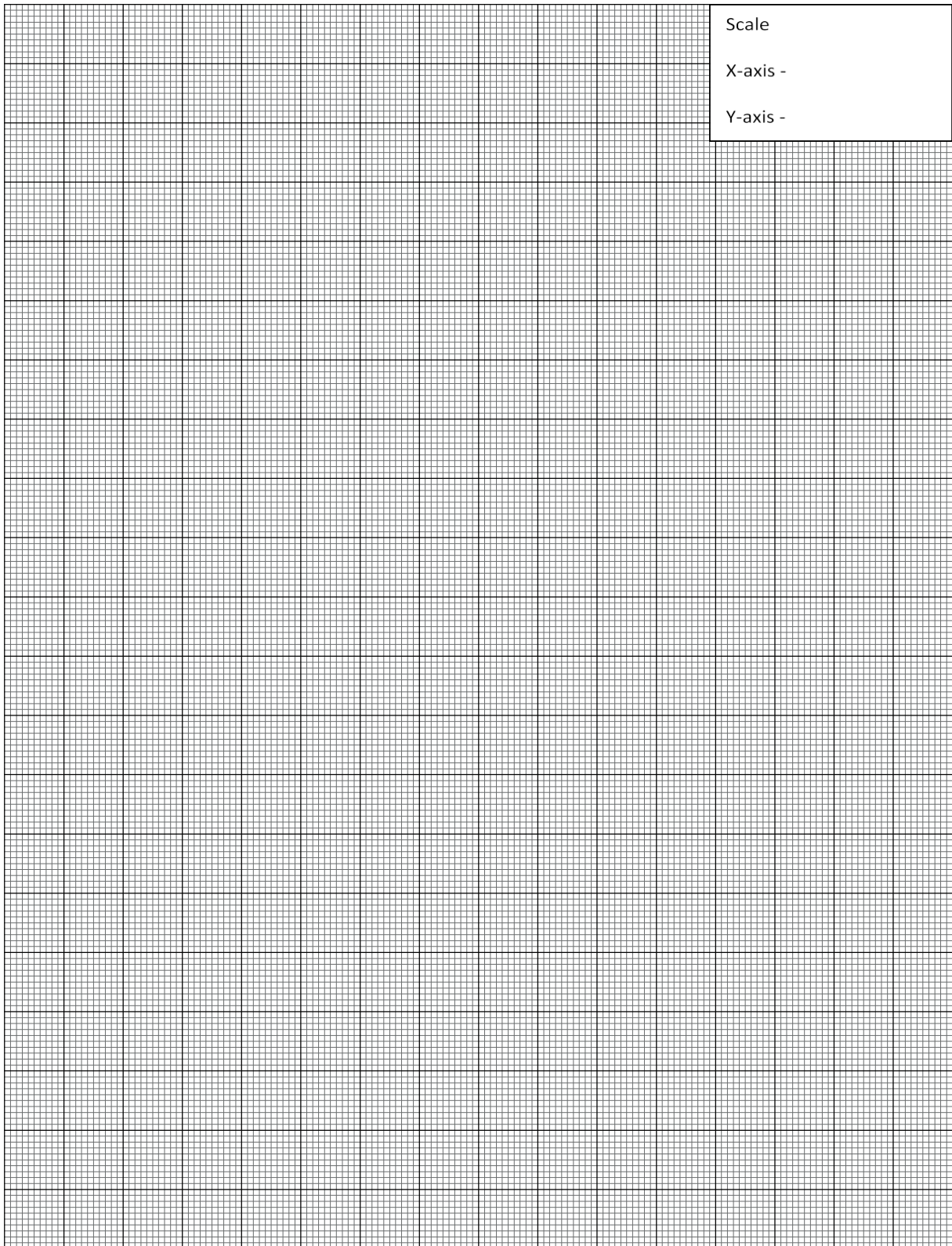

## Practical No. 08-A: Determine mechanical advantage and velocity ratio of two sheave pulley block for different load and effort.

### I. Practical Significance

There is often a need to lift loads and different lifting machines are used depending on the type of load, intensity of the load and other site conditions. Two sheave pulley blocks are used for lifting heavy loads in confined spaces. After conducting this experiment, a graduate engineer will be able to assess the suitability of a two-sheave pulley based on the given load lifting situation.

### II. Industry/Employer Expected Outcomes

Apply the principles of engineering mechanics to analyze, design and automation the prototypes and equipment's of various industries.

### III. Course Level Learning Outcome(s)

CO1-Select the suitable machine under given loading condition.

### IV. Laboratory Learning Outcome(s)

Verify law of machine under the given condition.

### V. Relevant Affective Domain related Outcome(s)

- Follow safety practices and precautions.
- Demonstrate working as a leader/a team member.
- Maintain tools and equipment.

### VI. Relevant Theoretical Background

**Two Sheave pulley block:** It also consists of upper block and lower block each having the pulleys in their sheave; therefore, total number of pulley are four. Upper block is fixed that of lower block is moveable. As the load  $W$  is equally shared by the four parts of the rope; tension ( $T$ ) in each rope is  $W/P$  for an ideal machine  $M.A. = V.R.$

Hence,

$$\text{Velocity Ratio (V.R.)} = \frac{(W)}{(\frac{W}{4})} = 4 \quad \therefore \text{V.R.} = 2 \times \text{Number of sheaves} \quad W = \text{Load}$$

### VII. Actual diagram used in laboratory with equipment specifications.

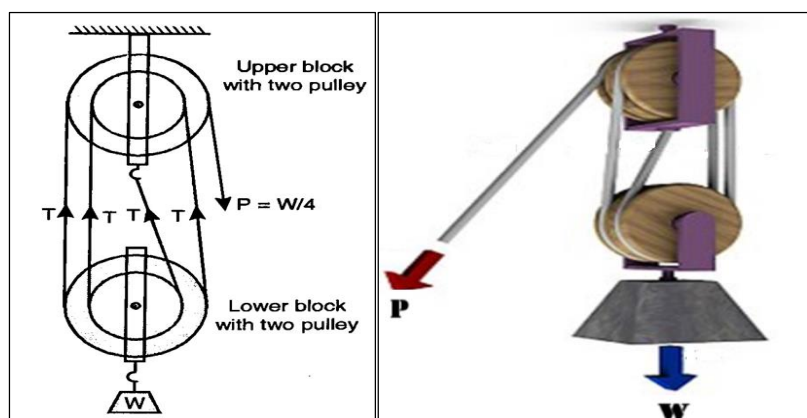

Fig. 8A.1 Two Sheaves Pulley Block

**VIII. Requires Recourses/Apparatus/Equipment with Specifications**

Sr. No.	Particulars	Broad Specifications	Quantity	Remarks (If Any)
1	Two sheaves pulley block	Two sheave pulley block consists of a metallic (preferably steel) cogged wheel of about 20 cm along with a protruded load drum of 10 cm diameter to suspend the weights of 10 kg, 20 kg and 50 kg weights.	01 for Group of 4 to 5 students.	

**IX. Precautions to be followed**

1. Effort must be applied gradually.

**X. Procedure**

1. Observe the machine carefully and identify the various components of machine.
2. Set the machine and check the reversibility of it.
3. Calculate friction in the given machine at zero load.
4. Apply the load starting with smaller magnitude.
5. Apply the effort for each corresponding load.
6. Record the observations of load and effort in observation table. Take at least five readings.
7. Measure the radius or number of cogs of larger and smaller pulley.
8. Determine M.A., V.R., Efficiency, Ideal effort and Effort lost in friction for given pulley block.
9. Plot graphs load against effort and load against efficiency.

**Observations and Calculations**

$$V. R. = \frac{(W)}{\left(\frac{W}{4}\right)} = 4$$

**XI. Observations Table**

Sr. No.	Load W (N)	Effort P (N)	M.A.	Velocity Ratio	Efficiency $\eta$ (%)	Ideal Effort $P_i$ (N)	Effort Lost in Friction $P_f$ (N)
1							
2							
3							
4							
5							

**Sample Calculations**

$$M. A. = \frac{\text{Load}}{\text{Effort}} = \frac{W}{P} =$$

$$\text{Efficiency } (\eta) = \frac{M. A.}{V. R.} \times 100\% =$$

$$P_i = \frac{W}{V. R.} =$$

$$P_f = P - P_i =$$

Law of Machine is  $P = mW + C$

Where,

$$M = \text{Slope} = \frac{P_2 - P_1}{W_2 - W_1} =$$

$C = Y$  intercept (i.e. Machine Friction) = \_\_\_\_\_ N

**XII. Results**

1. The law of machine is  $P = (\dots\dots\dots) W + (\dots\dots\dots) N$
2. The average efficiency of machine is = ..... %

**XIII. Interpretation of results**

Machine is .....

Friction loss is (i.e.  $Y -$  intercept = ..... ) reduced by ..... the machine.

The graph between load and effort is a straight line which indicates.....

The graph between load and efficiency is a curve which indicates.....

.....

**XIV. Conclusions and Recommendations**

.....  
.....  
.....

**XV. Practical Related Questions**

Note: Below given are few sample questions for reference. Teachers must design more such questions so as to ensure the achievement of identified CO. Write answers of minimum three questions.

1. Differentiate between single sheave and two sheave pulley block.
2. Write use of two sheave in working of machine.
3. State the two situations in field where two sheave pulley block is used.
4. Give reason. Chain is not slipping from the pulley when the load is being lifted.
5. State velocity ratio of two sheave block.





**XVII. Suggested Assessment Scheme**

Performance Indicators		Weightage (%)
<b>Process related: 15 Marks</b>		<b>60 %</b>
1	Handling of the machine.	5 %
2	Determination of V. R. of machine.	10 %
3	Applying load and determine effort of machine.	20 %
4	Identify the type of machine i.e. reversible or self-locking.	10 %
5	Calculation of parameters concerned.	10 %
6	Working in team.	5 %
<b>Product related: 10 Marks</b>		<b>40 %</b>
1	Error estimation.	5 %
2	Interpretation of result and graph.	10 %
3	Conclusion and Recommendation.	10 %
4	Answer to the practical related questions.	10 %
5	Submission of report in time.	5 %
<b>Total: 25 Marks</b>		<b>100 %</b>

Marks Obtained			Dated sign of Teacher
Process Related(15)	Product Related(10)	Total(25)	

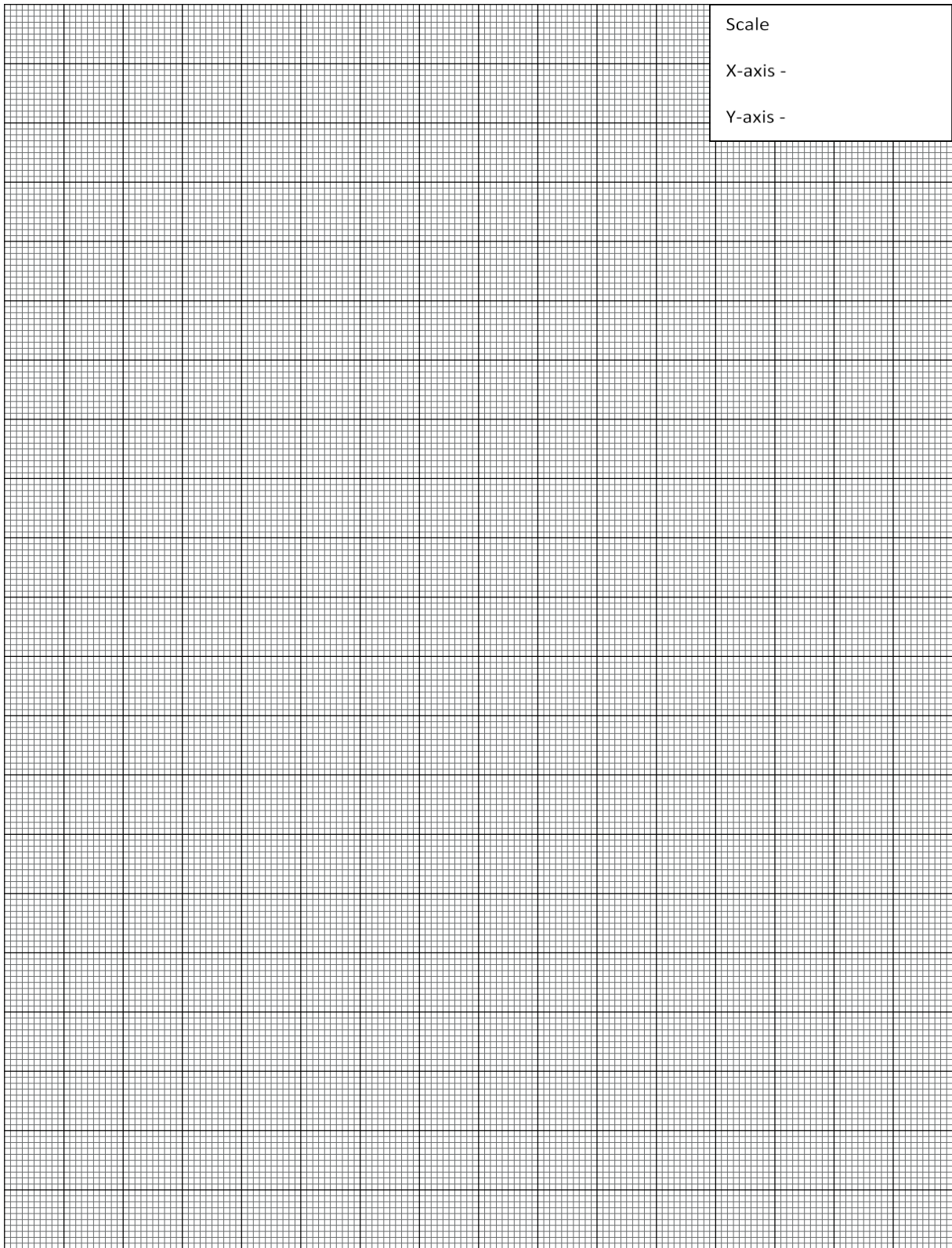

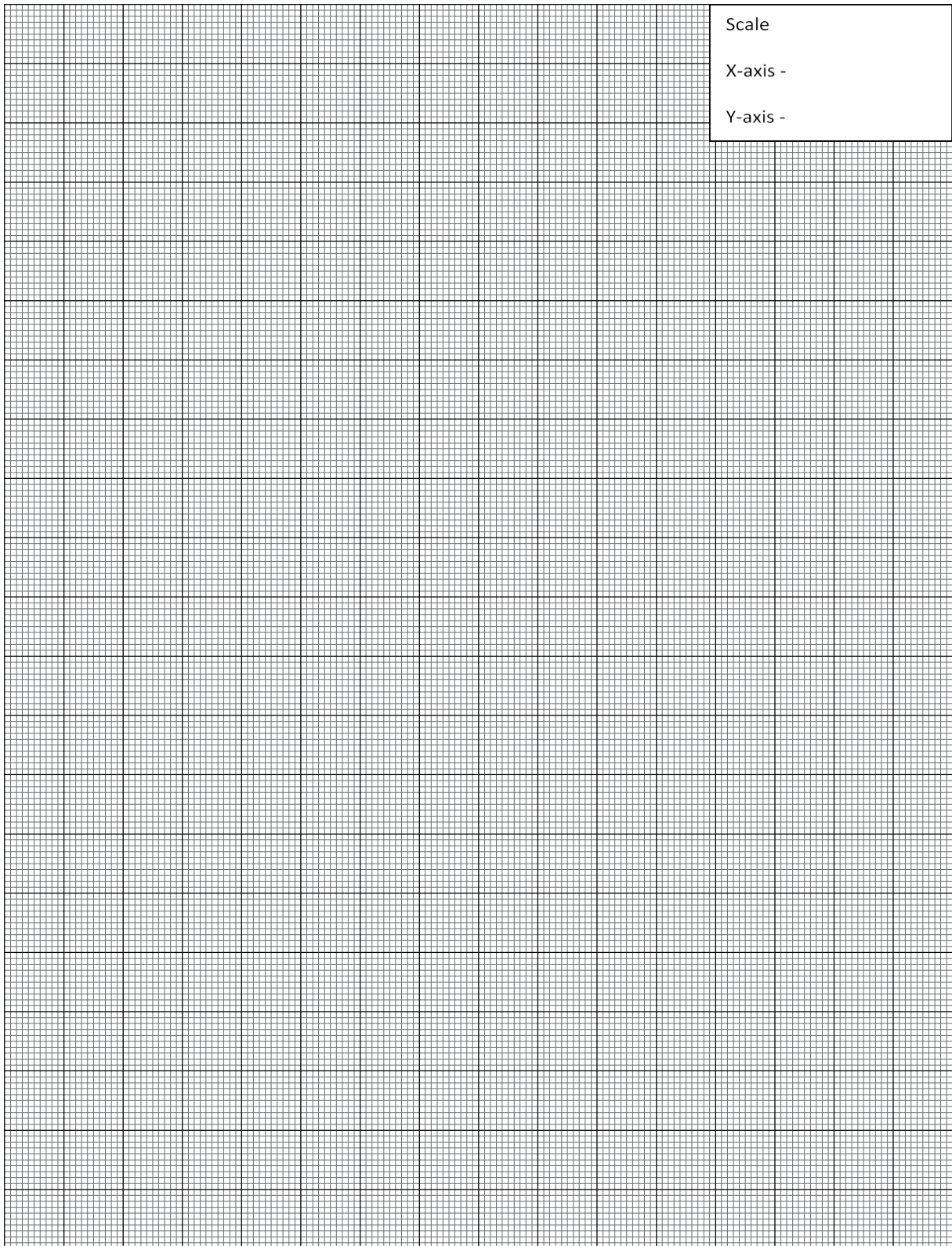

**Practical No. 08-B: Determine mechanical advantage and velocity ratio of three sheave pulley block for different load and effort.**

**I. Practical Significance**

There is often a need to lift loads and different lifting machines are used depending on the type of load, intensity of the load and other site conditions. Three sheave pulley blocks are used for lifting heavy loads in confined spaces. After conducting this experiment, a graduate engineer will be able to assess the suitability of a three-sheave pulley based on the given load lifting situation.

**II. Industry/Employer Expected Outcomes**

Apply the principles of engineering mechanics to analyze, design and automation the prototypes and equipment's of various industries.

**III. Course Level Learning Outcome(s)**

CO1-Select the suitable machine under given loading condition.

**IV. Laboratory Learning Outcome(s)**

Verify law of machine under the given condition.

**V. Relevant Affective Domain related Outcome(s)**

- a. Follow safety practices and precautions.
- b. Demonstrate working as a leader/a team member.
- c. Maintain tools and equipment.

**VI. Relevant Theoretical Background**

**Two Sheave pully block:** It also consists of upper block and lower block each having the pulleys in their sheave; therefore, total number of pulley are four. Upper block is fixed that of lower block is moveable. As the load  $W$  is equally shared by the four parts of the rope; tension ( $T$ ) in each rope is  $W/P$  for an ideal machine  $M.A. = V.R.$

Hence, 
$$\text{Velocity Ratio (V.R.)} = \frac{(W)}{\left(\frac{W}{6}\right)} = 6 \therefore V.R. = 2 \times \text{Number of sheaves} \quad W = \text{Load}$$

**VII. Actual diagram used in laboratory with equipment specifications.**

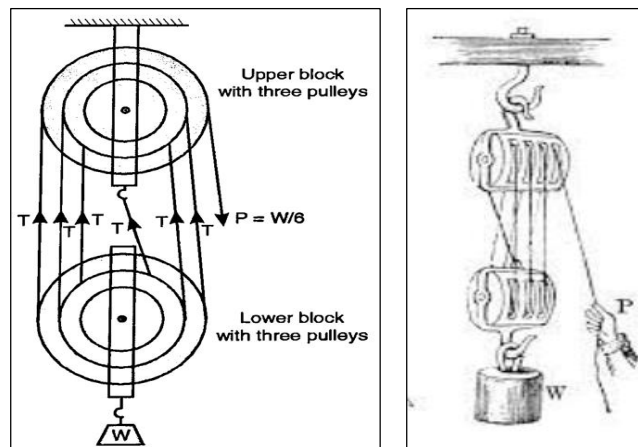

**Fig. 8B.1 Three Sheaves Pulley Block**

**VIII. Requires Recourses/Apparatus/Equipment with Specifications**

Sr. No.	Particulars	Broad Specifications	Quantity	Remarks (If Any)
1	Three sheaves pulley block	Three sheave pulley block consists of a metallic (preferably steel) cogged wheel of about 20 cm along with a protruded load drum of 10 cm diameter to suspend the weights of 10 kg, 20 kg and 50 kg weights.	01 for Group of 4 to 5 students.	

**IX. Precautions to be followed**

1. Effort must be applied gradually

**X. Procedure**

1. Observe the machine carefully and identify the various components of machine.
2. Set the machine and check the reversibility of it.
3. Calculate friction in the given machine at zero load.
4. Apply the load starting with smaller magnitude.
5. Apply the effort for each corresponding load.
6. Record the observations of load and effort in observation table. Take at least five readings.
7. Measure the radius or number of cogs of larger and smaller pulley.
8. Determine M.A., V.R., Efficiency, Ideal effort and Effort lost in friction for given pulley block.
9. Plot graphs load against effort and load against efficiency.

**Observations and Calculations**

$$V. R. = \frac{(W)}{\left(\frac{W}{6}\right)} = 6$$

**XI. Observations Table**

Sr. No.	Load W (N)	Effort P (N)	M.A.	Velocity Ratio	Efficiency $\eta$ (%)	Ideal Effort Pi (N)	Effort Lost in Friction Pf (N)
1							
2							
3							
4							
5							

**Sample Calculations**

$$M. A. = \frac{\text{Load}}{\text{Effort}} = \frac{W}{P} =$$

$$\text{Efficiency } (\eta) = \frac{M. A.}{V. R.} \times 100\% =$$

$$P_i = \frac{W}{V. R.} =$$

$$P_f = P - P_i =$$

Law of Machine is  $P = mW + C$

Where,

$$M = \text{Slope} = \frac{P_2 - P_1}{W_2 - W_1} =$$

$C = Y$  intercept (i.e. Machine Friction) = \_\_\_\_\_ N

**XII. Results**

1. The law of machine is  $P = (\dots\dots\dots) W + (\dots\dots\dots) N$
2. The average efficiency of machine is = ..... %

**XIII. Interpretation of results**

Machine is .....

Friction loss is (i.e.  $Y -$  intercept = .....) reduced by ..... the machine.

The graph between load and effort is a straight line which indicates.....

The graph between load and efficiency is a curve which indicates.....

.....

**XIV. Conclusions and Recommendations**

.....  
.....  
.....

**XV. Practical Related Questions**

Note: Below given are few sample questions for reference. Teachers must design more such questions so as to ensure the achievement of identified CO. Write answers of minimum three questions.

1. State the given machine is reversible or not. Give reason.
2. State the capacity of three, sheave pulley block.
3. State the two situations in field where two sheave pulley block is used.
4. Write use of three sheave in working of machine.
5. State velocity ratio of three sheave block.





**XVII. Suggested Assessment Scheme**

Performance Indicators		Weightage (%)
<b>Process related: 15 Marks</b>		<b>60 %</b>
1	Handling of the machine.	5 %
2	Determination of V. R. of machine.	10 %
3	Applying load and determine effort of machine.	20 %
4	Identify the type of machine i.e. reversible or self-locking.	10 %
5	Calculation of parameters concerned.	10 %
6	Working in team.	5 %
<b>Product related: 10 Marks</b>		<b>40 %</b>
1	Error estimation.	5 %
2	Interpretation of result and graph.	10 %
3	Conclusion and Recommendation.	10 %
4	Answer to the practical related questions.	10 %
5	Submission of report in time.	5 %
<b>Total: 25 Marks</b>		<b>100 %</b>

Marks Obtained			Dated sign of Teacher
Process Related(15)	Product Related(10)	Total(25)	

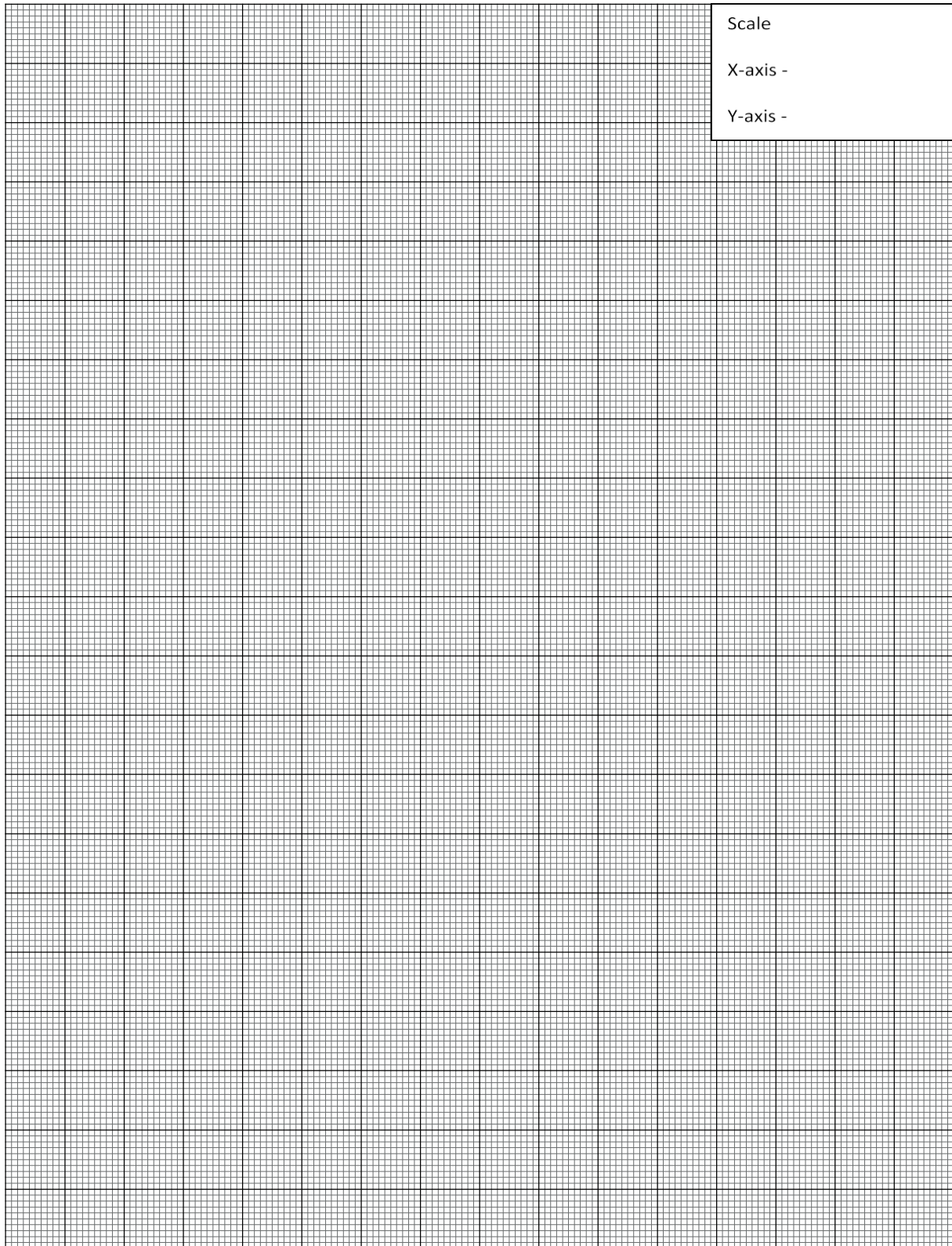

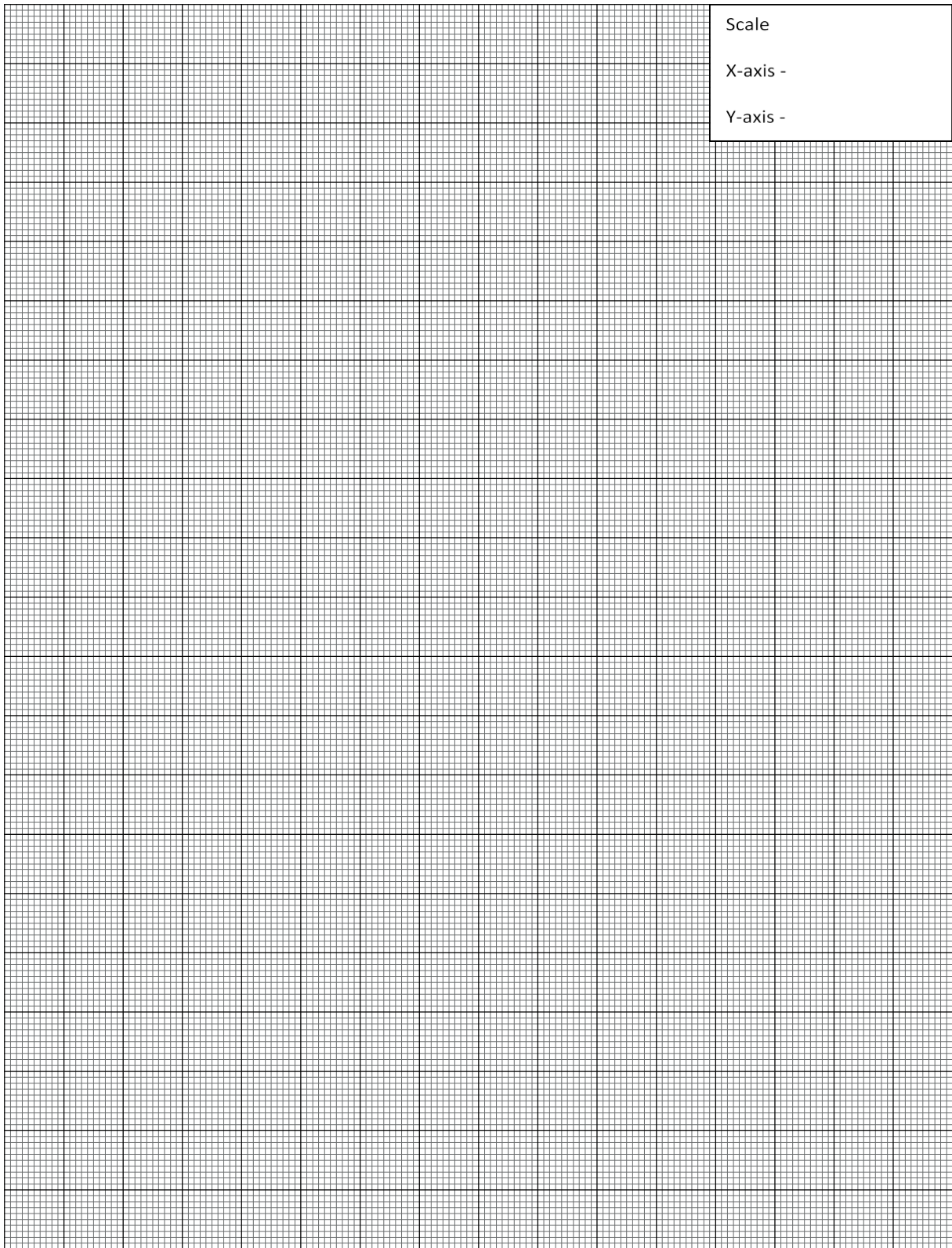

## **Practical No. 09: Verify law of polygon of forces using Universal force table for given forces.**

### **I. Practical Significance**

Many times there is a need to determine the resultant force. Depending upon the type of force system resultant can be determined by applying law of polygon of forces. After performing this experiment students will be able to find the resultant of three or more forces by graphically using law of polygon.

### **II. Industry/Employer Expected Outcomes**

Apply the principles of engineering mechanics to find resultant of concurrent forces acting on structure (analytically and graphically).

### **III. Course Level Learning Outcome(s)**

CO2 - Analyze the given force system to calculate resultant force.

### **IV. Laboratory Learning Outcome(s)**

Analyze the resultant force of given force system.

### **V. Relevant Affective Domain related Outcome(s)**

- a. Follow safety practices and precautions.
- b. Demonstrate working as a leader/a team member.
- c. Maintain tools and equipment.

### **VI. Relevant Theoretical Background**

The law states that “If a number of forces acting simultaneously on a particle, be represented in magnitude and direction, by sides of a polygon taken in order, then the resultant of all these forces is represented in magnitude and direction by closing side of polygon taken in opposite direction.”

This experiment is used to study the forces acting on a particle with the help of Universal force table as shown in figure.

### **VII. Actual diagram used in laboratory with equipment specifications.**



**Fig. 9.1 Universal Force table**

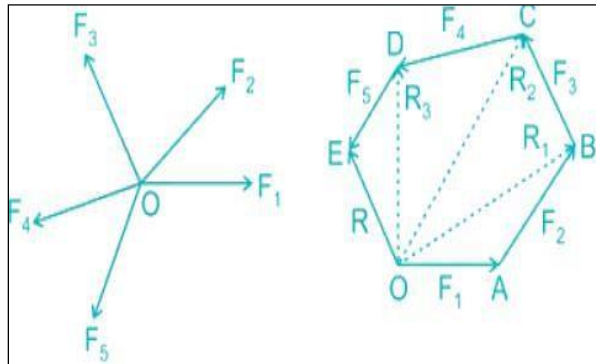

Fig. 9.2 Polygon

### VIII. Requires Recourses/Apparatus/Equipment with Specifications

Sr. No.	Particulars	Broad Specifications	Quantity	Remarks (If Any)
1	Universal Force Table	It Consists of circular 40cm dia. Aluminium disc, graduated into 360degrees with all accessories	01 for Group of 4 to 5 students	
2	Slotted weights	50gms and 100gms	3 sets of 5 weight each	
3	Cotton String			

### IX. Precautions to be followed

1. All the pulleys should be free from friction.
2. Pivot and ring must be concentric with each other.
3. Angles should be measured carefully.

### X. Procedure

1. Place the universal force table on plane surface. Make the circular disc in horizontal position with the help of foot screws and also check position with spirit level.
2. Attach five pulleys at such position that angle between any two is not very acute angle.
3. Pass the thread on these pulleys as shown in fig & attach the pan to each thread.
4. Put some weights on each pan (or hang slotted weights with each thread) and adjust the weights such that the ring is exactly in the centre under the effect of all this forces.
5. Note the sum of slotted weights in each hanger and weight of hanger and consider it as one force  $F_1$  and next forces  $F_2, F_3, F_4, F_5$  in order. Also note down angle between them.
6. Repeat the step 5 by changing any one or two pulleys position and take three set of observation and Select a suitable scale & draw a polygon taking the forces in order.
7. Since all forces are in equilibrium the polygon shall be closed one.
8. If the polygon is not closed one calculate the closing error by analytical and graphical method.

**XI. Observations Table**

Obs. No.	Magnitude of Forces in (N) (Weight in hanger +Weight of hanger)					Angles between two forces in(degree)					
	F1	F2	F3	F4	F5 (From graph)	$\theta_1$	$\theta_2$	$\theta_3$	$\theta_4$	$\theta_5$	$\theta_5$ From graph
1											
2											
3											
4											
5											

**XII. Results**

1. The force polygon is closed/not closed.

**XIII. Interpretation of results**

.....  
 .....  
 .....

**XIV. Conclusions and Recommendations**

1. If the force polygon is closed.....
2. If the force polygon is not closed.....

**XV. Practical Related Questions**

Note: Below given are few sample questions for reference. Teachers must design more such questions so as to ensure the achievement of identified CO. Write answers of minimum three questions.

1. State & explain law of polygon of forces.
2. What can be the sources of error in this experiment?
3. Distinguish the following system of forces with a suitable sketch. a) Coplanar b) concurrent c) Parallel d) Collinear.
4. If the force polygon is not a closed figure, what does it indicates.

**Space for answers**

.....  
 .....



**XVI. References/Suggestions for further Reading**

Sr. No.	Link	Description
1	<a href="https://www.youtube.com/watch?v=Fudcc0JoXdo">https://www.youtube.com/watch?v=Fudcc0JoXdo</a>	Force System
2	<a href="https://www.youtube.com/watch?v=ljDIIMvx-eg">https://www.youtube.com/watch?v=ljDIIMvx-eg</a>	Equilibrium of Rigid bodies
3	<a href="https://5.imimg.com/data5/OW/MR/ET/SELLER-10457901/force-table-250x250.jpg">https://5.imimg.com/data5/OW/MR/ET/SELLER-10457901/force-table-250x250.jpg</a>	Universal Force Table Image

**XVII. Suggested Assessment Scheme**

Performance Indicators		Weightage (%)
<b>Process related: 15 Marks</b>		<b>60 %</b>
1	Handling of the machine.	5 %
2	Calculation of force.	10 %
3	Measurement of angle.	10 %
4	Proper Reading	10 %
5	Calculation of parameters concerned.	10 %
6	Drawing force polygon	10%
7	Working in team.	5 %
<b>Product related: 10 Marks</b>		<b>40 %</b>
1	Error estimation.	5 %
2	Interpretation of result and graph.	10 %
3	Conclusion and Recommendation.	10 %
4	Answer to the practical related questions.	10 %
5	Submission of report in time.	5 %
<b>Total: 25 Marks</b>		<b>100 %</b>

Marks Obtained			Dated sign of Teacher
Process Related(15)	Product Related(10)	Total(25)	

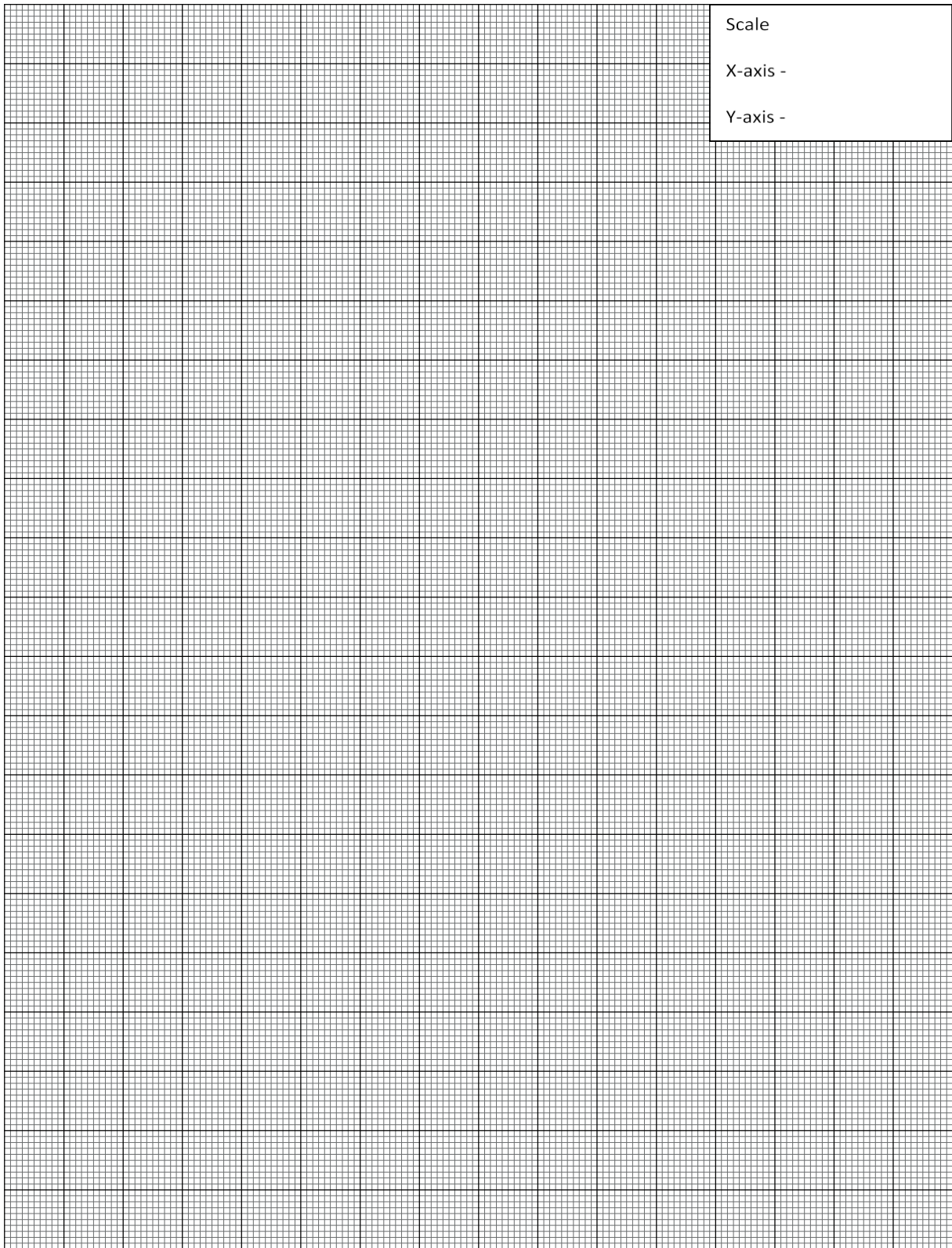

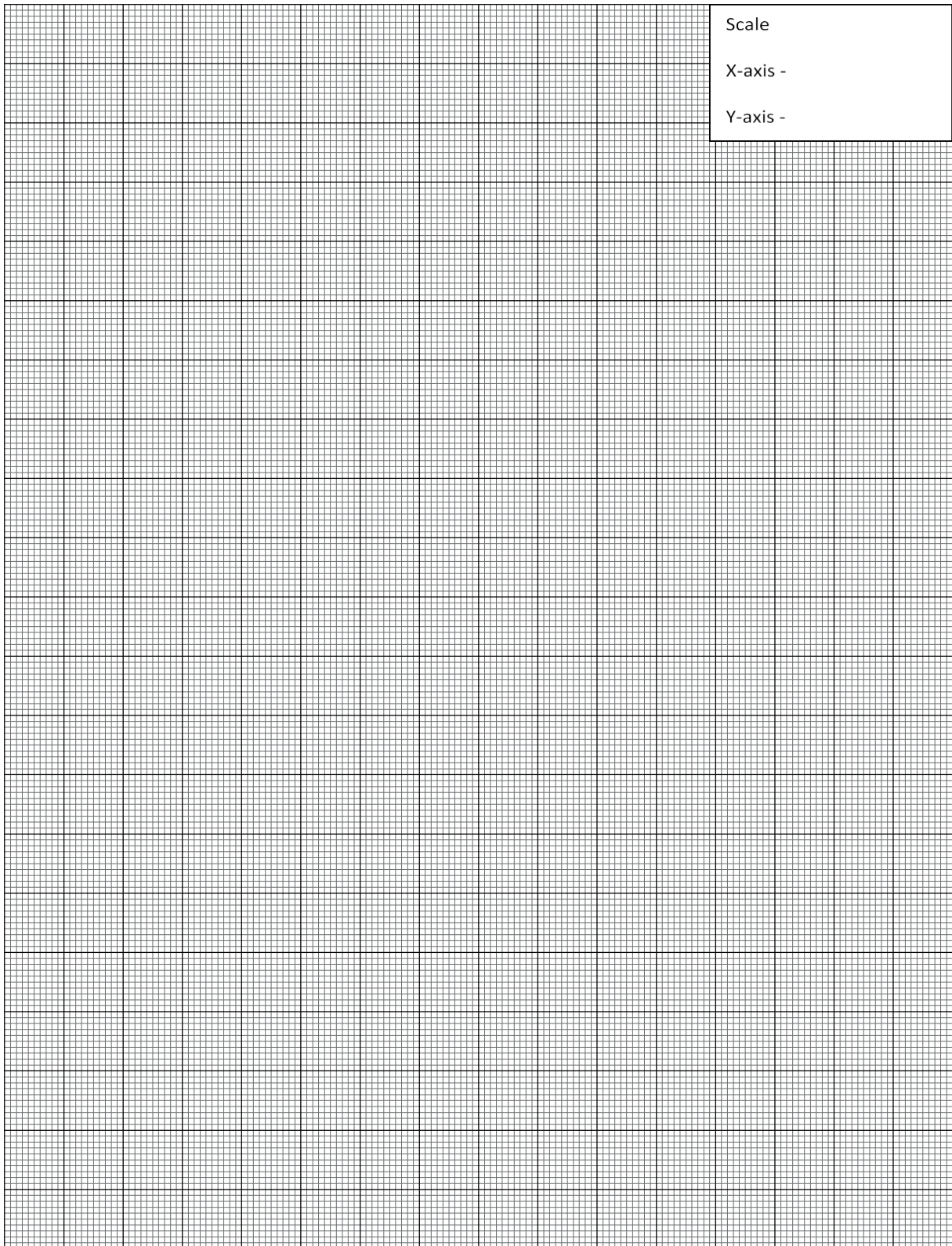

## Practical No. 10: Verify law of moment of forces using law of moment apparatus for given forces.

### I. Practical Significance

The Principle of Moments states that when a body is balanced, the total clockwise moment about a point equals the total anticlockwise moment about the same point. The real examples on moment of force in real life are the opening and closing of a door along a fixed hinge, a seesaw, and unscrewing a nut with a spanner.

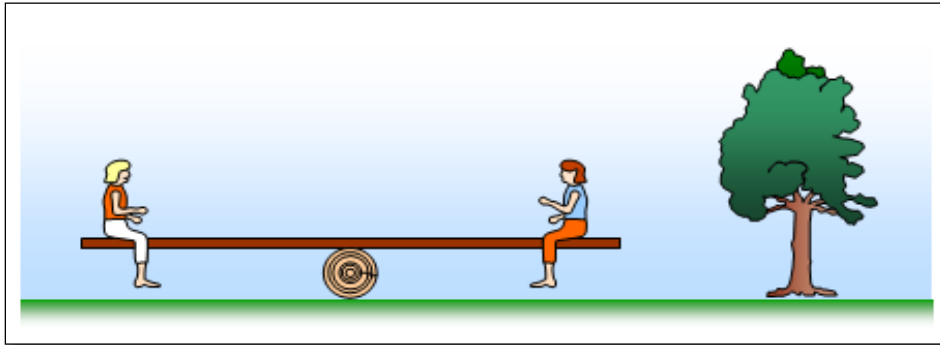

**Fig.10.1**

When an object is balanced on a pivot the turning effect of the forces on one side of the pivot must balance the turning effect of the forces on the other side of the pivot - if they didn't it would not balance. In the picture (Fig.10.1) two girls are sitting on a see saw. They have moved until it is balanced. They are the same weight and so to balance the see saw they must sit the same distance from the pivot.

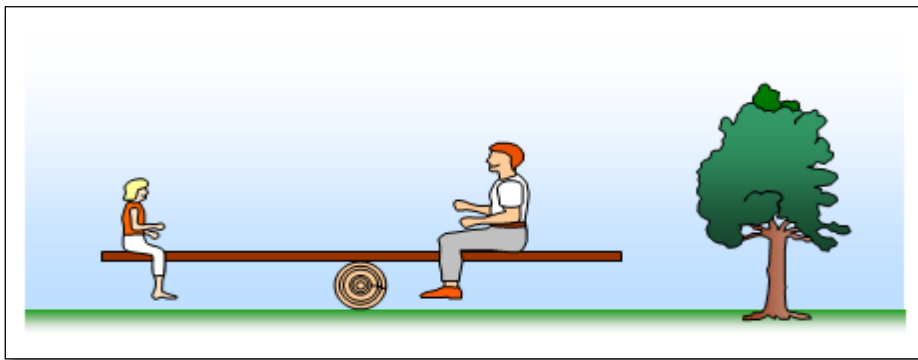

**Fig.10.2**

In the picture (Fig.10.2) one of the girls gets off and a man sits on instead. They move until the see saw is balanced. The girl is much lighter than the man and so she has to sit further away from the pivot than he does so that she can balance his extra weight.

You should remember that the turning effect of a force is called the moment of the force and is found by multiplying the force by its distance from the pivot. When the see saw is balanced we say that the anticlockwise moments (those trying to turn the object anticlockwise) equal the Clockwise moments (those trying to turn the object clockwise). In our example the man's weight tries to turn the see saw clockwise and the girl's weight tries to turn it anticlockwise.

**II. Industry/Employer Expected Outcomes**

Moment of force has numerous applications in various fields of science and engineering, including in automobiles (torque is used to measure the power output of an engine), in robotics, torque is used to control the movement of robot arms and joints. Industrial machinery, torque is Used to measure the effectiveness of machines. Moment of force is used in sports such as gymnastics, diving, and ice skating to perform complex rotational movements. Moment of force is used in biology to understand the mechanics of biological systems, such as the motion of joints in the human body.

**III. Course Level Learning Outcome(s)**

CO2 - Analyze the given force system to calculate resultant force

**IV. Laboratory Learning Outcome(s)**

Analyze the resultant force of given force system.

**V. Relevant Affective Domain related Outcome(s)**

- a. Follow safety practices and precautions.
- b. Demonstrate working as a leader/a team member.
- c. Maintain tools and equipment.

**VI. Relevant Theoretical Background**

The Principle of Moments states that when a body is balanced, the total clockwise moment about a point equals the total anticlockwise moment about the same point. Clockwise and Anticlockwise moment example as shown below.

**VII. Actual diagram used in laboratory with equipment specifications.**

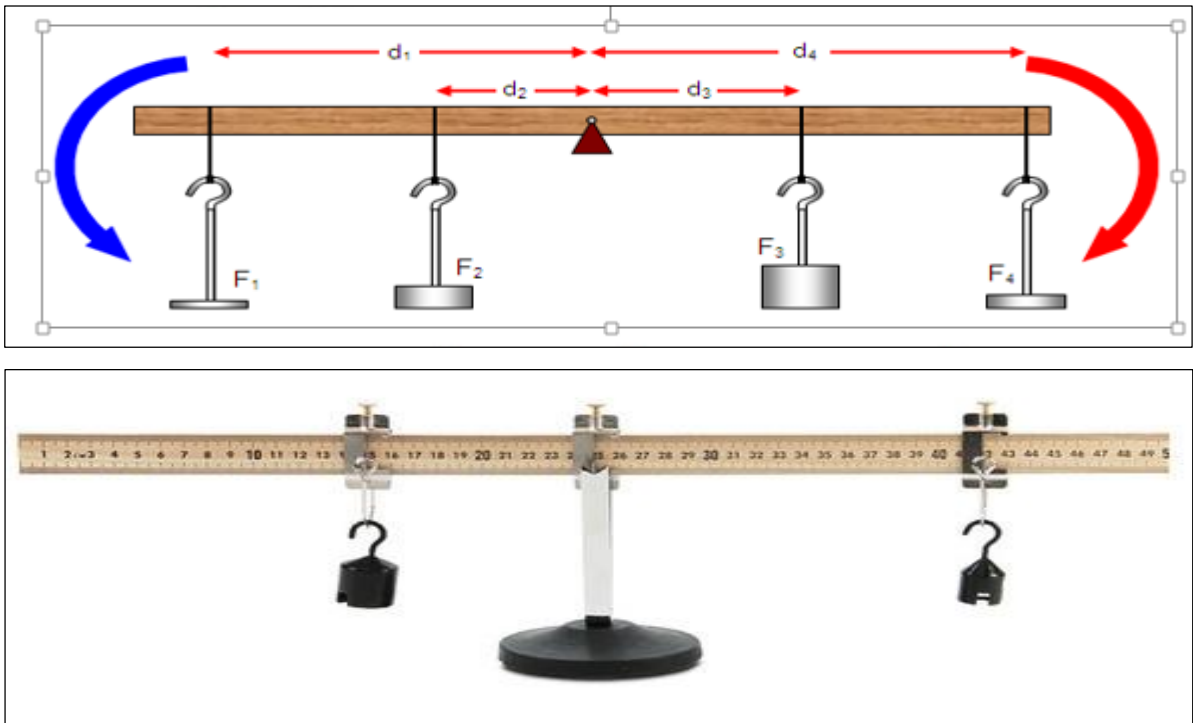

**Fig. 10.3 Law of moment apparatus.**

The Above diagram (Figure 3) shows the effect of having more than one force on each side of the pivot. The Law of Moment is given by  $F_1d_1 + F_2d_2 = F_3d_3 + F_4d_4$ .

**VIII. Requires Recourses/Apparatus/Equipment with Specifications**

Sr. No.	Particulars	Broad Specifications	Quantity	Remarks (If Any)
1	Meter rule	With small hole drilled at 50cm mark.	01 for Group of 4 to 5 students	
2	Smooth optical pin	At least 5cm Long	01	
3	Slotted weights	50gms and 100gms	Three sets of 5 weight each	
4	Split cork		01	

**IX. Precautions to be followed**

1. Meter rule should be perfectly horizontal.
2. Pivot should be at the center.
3. Weight should be place properly at required distance.

**X. Procedure**

1. Place unequal weights on each side of the pivot.
2. Move the weight until the meter rule balances.
3. When this occurs take note of the anti-clockwise and clockwise moments.
4. Repeat several times by changing distance on each side. And take more sets of observations.

**XI. Observations Table**

Sr. No.	Force $F_1(N)$	Force $F_2(N)$	Distance $d_1(cm)$	Distance $d_2(cm)$	Anti-clockwise Moment $F_1 d_1(N-cm)$	Clockwise Moment $F_2 d_2 (N-cm)$
1						
2						
3						
4						
5						

**XII. Results**

1. Anticlockwise moment and Clockwise moment are..... (Equal/Nearly eual/Not equal).
1. The difference in anticlockwise moment and Clockwise moment is because of.....(Error of manipulation/Instrument error/observation error)





**XVII. Suggested Assessment Scheme**

Performance Indicators		Weightage (%)
<b>Process related: 15 Marks</b>		<b>60 %</b>
1	Handling of the machine.	5 %
2	Application of different weights at different locations.	15 %
3	Observation of weights and distances.	10 %
4	Measuring of weights and distances.	10 %
5	Calculation of clockwise and anticlockwise moments.	15 %
6	Working in team.	5 %
<b>Product related: 10 Marks</b>		<b>40 %</b>
1	Error estimation.	5 %
2	Interpretation of result and graph.	10 %
3	Conclusion and Recommendation.	10 %
4	Answer to the practical related questions.	10 %
5	Submission of report in time.	5 %
<b>Total: 25 Marks</b>		<b>100 %</b>

Marks Obtained			Dated sign of Teacher
Process Related(15)	Product Related(10)	Total(25)	

## Practical No. 11: Verify the Lamis theorem using Universal force table apparatus for given forces.

### I. Practical Significance

Lami's theorem relates the magnitudes of coplanar, concurrent and non-collinear forces that maintain an object in static equilibrium. The theorem is very useful in analyzing most of the mechanical as well as structural systems.

Lami's theorem has been obtained from the Sine Rule for triangles. By representing the forces as lines as in a free-body diagram and translating them in such a way that one head touches the tail of another, then it will be noticed that when there are three forces, if they are supposed to cancel each other, they resultantly form a triangle. If they are not supposed to cancel each other, they form an open curve. The Sine Rule is only applicable for triangles only and hence Lami's Theorem is only applicable to three forces, but not for the 'n' number of forces.

### II. Industry/Employer Expected Outcomes

After Studying this Practical Students will be able to find tension in string in three coplanar, concurrent forces.

### III. Course Level Learning Outcome(s)

CO3 - Determine unknown force(s) of given load combinations in the given situation.

### IV. Laboratory Learning Outcome(s)

Analyse the resultant force of given force system.

### V. Relevant Affective Domain related Outcome(s)

- a. Follow safety practices and precautions.
- b. Demonstrate working as a leader/a team member.
- c. Maintain tools and equipment.

### VI. Relevant Theoretical Background

If three coplanar forces acting at a point are in equilibrium then each force is directly proportional to the Sin of the angle included between the other two forces. By using simple weights, pulleys & strings placed around a circular table, several forces can be applied to an object located in the centre of the table in such a way that the forces exactly cancel each other, leaving the objects in equilibrium (the object will appear to be at rest). Force table and Newton's First Law is used to study the components at the force vector.

### VII. Actual diagram used in laboratory with equipment specifications.

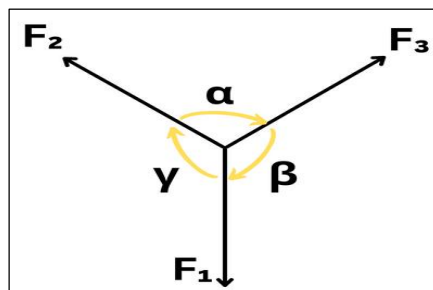

**Fig.11.1 Lamis Theorem**



**Fig.11.2 Universal Force table**

The Above diagram (Figure 3) shows the effect of having more than one force on each side of the pivot. The Law of Moment is given by  $F_1d_1 + F_2d_2 = F_3d_3 + F_4d_4$ .

### VIII. Requires Recourses/Apparatus/Equipment with Specifications

Sr. No.	Particulars	Specification	Quantity	Remark
1	Universal Force table	Circular graduated disc supported on rd and the assembly supported on three adjustable screws	01 for Group of 4to5 students	
2	Circular ring of metal tied to the three strings.		One ring Three strings.	
3	Load Hanger	50gms and 100gms	3Nos each	
4	Slotted weights	50gms and 100gms	Three sets of 5 weight each	
5	Spirit level	10cm Long	One	

### IX. Precautions to be followed

1. Hangers should sit in pulleys properly.
2. All the pulleys should be free from friction.
3. Force table should be perfectly horizontal.
4. Pivot and ring must be concentric with each other.

### X. Procedure

1. Place the Universal Force Table on firm platform.
2. Make the circular disc in horizontal position with the help of boot screws.
3. Check the horizontal position of circular disc by spirit level
4. Clamp the three detachable pulleys to the circular disc at three different positions.
5. Keep the ring at the centre of disc and pass the other ends of each string over the three pulleys.
6. Hang three hangers to these ends of strings passing over the pulleys.

7. Put slotted weights to each hanger so as to make pivot and ring concentric with each other.
8. Note the sum of slotted weights in each hanger and weight of hanger as three forces F1, F2, F3.
9. Measure the angles included between the two adjacent pulleys and note them as  $\theta_1, \theta_2, \theta_3$ .
10. Record these observations in table.
11. Repeat step (7) by changing one or two pulleys position and take two sets of observation.

**XI. Observations Table**

Sr. No.	Force(N)			Angle(Degree)			Ratio		
	P	Q	R	$\alpha$	B	$\gamma$	$P/\sin \alpha$	$Q/\sin \beta$	$R/\sin \gamma$
1									
2									
3									
4									

**XII. Results**

1. Ratios  $P/\sin \alpha, Q/\sin \beta, R/\sin \gamma$  are.....(Equal/Nearly equal/Not equal).

**XIII. Interpretation of results**

If the ratio of force to the sin of opposite angle remains constant then the third observed equilibrant force is correct.

**XIV. Conclusions and Recommendations**

.....  
 .....  
 .....

**XV. Practical Related Questions**

Note: Below given are few sample questions for reference. Teachers must design more such questions so as to ensure the achievement of identified CO.

1. Define Lamis theorem.
2. Give the Practical Example where Lamis theorem is used.
3. State limitations of Lamis theorem.

**Space for answers**

.....  
 .....  
 .....  
 .....  
 .....  
 .....  
 .....  
 .....



**XVII. Suggested Assessment Scheme**

<b>Performance Indicators</b>		<b>Weightage (%)</b>
<b>Process related: 15 Marks</b>		<b>60 %</b>
1	Handling of force table.	5 %
2	Application of different weight at different location.	15 %
3	Observation of weight in hanger and included angles.	5 %
4	Measuring of weights in hangers and included angles.	15 %
5	Calculation of third equilibrant force	15 %
6	Working in team.	5 %
<b>Product related: 10 Marks</b>		<b>40 %</b>
1	Error estimation.	5 %
2	Interpretation of result and graph.	10 %
3	Conclusion and Recommendation.	10 %
4	Answer to the practical related questions.	10 %
5	Submission of report in time.	5 %
<b>Total: 25 Marks</b>		<b>100 %</b>

<b>Marks Obtained</b>			<b>Dated sign of Teacher</b>
<b>Process Related(15)</b>	<b>Product Related(10)</b>	<b>Total(25)</b>	

**Practical No. 12: Determine support reaction of simply supported beam using parallel forces of beam reaction apparatus for given vertical forces.**

**I. Practical Significance**

A simply supported beam is one whose ends are resting freely on two supports that provide only vertical reaction. Typical practical applications of simply supported beams with point loadings include bridges, beams and beds of machine tools.

**II. Industry/Employer Expected Outcomes**

After Studying this Practical Students will be able to find support reactions of beam which further use for analysis of beam.

**III. Course Level Learning Outcome(s)**

CO3 - Determine unknown force(s) of given load combinations in the given situation.

**IV. Laboratory Learning Outcome(s)**

Analyse the given force system acting on structural element.

**V. Relevant Affective Domain related Outcome(s)**

- a. Follow safety practices and precautions.
- b. Demonstrate working as a leader/a team member.
- c. Maintain tools and equipment.

**VI. Relevant Theoretical Background**

The beam is said to be simply supported beam when only vertical reaction, at supports exist. In this experiment this condition is achieved by applying only vertical forces. The test is based on the ‘**Principle of Moments.**’ It states that if a system of coplanar forces acts on a rigid body, and the body remains in equilibrium despite the forces being acted upon, the summation of all the vertical forces acting on the body is zero, the summation of all the horizontal forces is zero and the algebraic sum of their moments at any point inside the plane is also zero.

Mathematically:

The body will be in equilibrium, if

$\Sigma H = 0$  i.e. the algebraic sum of all horizontal forces is zero.

$\Sigma V = 0$  i.e. the algebraic sum of all Vertical forces is zero.

$\Sigma M = 0$  i.e. the algebraic sum of all moments about a point is zero.

Parallel force apparatus to find support reaction of a simply supported beam meter scale, weights etc.

The apparatus consists of a graduated wooden beam supported at its ends on spring balance OR Dial type balance. The balance facilitates to read the reaction due to applied loads directly. The detachable hangers hold the desired load resting in the grooves.

**VII. Actual diagram used in laboratory with equipment specifications.**



**Fig. 12.1 Beam apparatus.**

**VIII. Requires Recourses/Apparatus/Equipment with Specifications**

Sr. No.	Particulars	Specification	Quantity	Remark
1	Beam apparatus	1000mm long beam with Scale fitted along length.	01 for Group of 4 to5 student	
2	Force measuring Dials	Laest count:100gm Max:10kg	2Nos	
3	Measuring weights	500gms	3Nos. 3Nos	
4	Load Hangers	1000gms	3Nos.	

**IX. Precautions to be followed**

1. Dials to be set to zero before loading the beam.
2. Measure the Distance accurately.
3. Hangers should be sit in the grooves properly.

**X. Procedure**

1. Keep the Beam Reaction Apparatus on the table.
2. Note down the initial reading of parallel force apparatus both left &right.
3. For one point load put one weight hanger and attach some weight to the weight hanger.
4. Note down the weight attach and its distance from left support and reading of compression balance both left and right.
5. For two point load attach two weight hanger at any point and note down the weight its distance from left support and reading of compression balance both left and right.
6. For three point load attach three weight hanger at any point and note down the weight its distance from left support and reading of compression balance both left and right.
7. Find the experimental value of reaction of the support by subtracting the initial reading of compression balance from the final reading.

8. Also find reaction by applying condition of equilibrium. Summation of  $F_y=0$ , summation of  $M=0$ .
9. Compare the experimental and theoretical value of support reaction.

**XI. Observations Table**

Sr. No.	Load W1(N)	Load W2(N)	Distance X1(mm)	Distance X2(mm)	Observed Reactions		Analytical Reactions	
					R <sub>A</sub> (N)	R <sub>B</sub> (N)	R <sub>A</sub> (N)	R <sub>B</sub> (N)
1								
2								
3								
4								
5								

**XII. Results**

1. Observed Reaction R<sub>A</sub> and Analytical Reaction R<sub>A</sub> .....  
(Equal/Nearly equal/Not equal)
2. Observed Reaction R<sub>B</sub> and Analytical Reaction R<sub>B</sub> .....  
(Equal/Nearly equal/Not equal)

**XIII. Interpretation of results**

.....  
 .....  
 .....

**XIV. Conclusions and Recommendations**

.....  
 .....  
 .....

**XV. Practical Related Questions**

Note: Below given are few sample questions for reference. Teachers must design more such questions so as to ensure the achievement of identified CO. Write answers of minimum three questions.

1. State different types of supports.
2. Explain types of beam with diagram.
3. Define the term Support reaction.
4. State the two situations in field where simply supported beams are used.

**Space for answers**

.....  
 .....





**XVII. Suggested Assessment Scheme**

Performance Indicators		Weightage (%)
<b>Process related: 15 Marks</b>		<b>60 %</b>
1	Handling of Beam Apparatus.	5 %
2	Application of different weight at different location.	15 %
3	Observation of weight and distance.	5 %
4	Measuring of weight and distance.	15 %
5	Reading Dialed gauge reading	15 %
6	Working in team.	5 %
<b>Product related: 10 Marks</b>		<b>40 %</b>
1	Error estimation.	5 %
2	Interpretation of result and graph.	10 %
3	Conclusion and Recommendation.	10 %
4	Answer to the practical related questions.	10 %
5	Submission of report in time.	5 %
<b>Total: 25 Marks</b>		<b>100 %</b>

Marks Obtained			Dated sign of Teacher
Process Related(15)	Product Related(10)	Total(25)	

## **Practical No. 13: Determine coefficient of friction using friction apparatus for given block on horizontal plane**

### **I. Practical Significance**

Friction is defined as resistive force offered by the surfaces that are in contact. When we kick a football it rolls for some distance and after that it stops after rolling for some time. This is because of the friction force between the ground and the ball. In this case force that is acting opposite to the motion of the ball and stops the ball is called the friction. Due to friction human can easily walk on surface without slipping. When a body is dragged along the rough plane friction force is more as compare to smooth surface because there is less interlocking between smooth surfaces Friction is very helpful in our daily activities like walking, running. Hence life would be very difficult without friction.

### **II. Industry/Employer Expected Outcomes**

Student will be able to apply the knowledge of frictional forces in automobile industries (braking system brings the vehicle to a stop). In construction industries (While making roads, runways and highways) etc.

### **III. Course Level Learning Outcome(s)**

CO4-Apply the laws of friction in the given situation.

### **IV. Laboratory Learning Outcome(s)**

Verify laws of forces related to forces.

### **V. Relevant Affective Domain related Outcome(s)**

- a. Follow safety practices and precautions.
- b. Demonstrate working as a leader/a team member.
- c. Maintain tools and equipment.

### **VI. Relevant Theoretical Background**

When there is a motion or tendency of motion between two surfaces in contact the Friction exists. The frictional force is opposite to the motion. In some practical situations the friction is required to reduce using lubrication. When the force causes the motion increases, the frictional force is also increased proportionately. Hence when the both are at the point of motion the frictional force is Maximum. This friction is known as Limiting Friction. Normal Reaction(R): The reaction which is right angle to the plane of motion is called as normal reaction. Coefficient of friction ( $\mu$ ): Is defined as ratio of limiting friction to normal reaction.

### **VII. Actual diagram used in laboratory with equipment specifications.**



**Fig.13.1 Friction Apparatus**

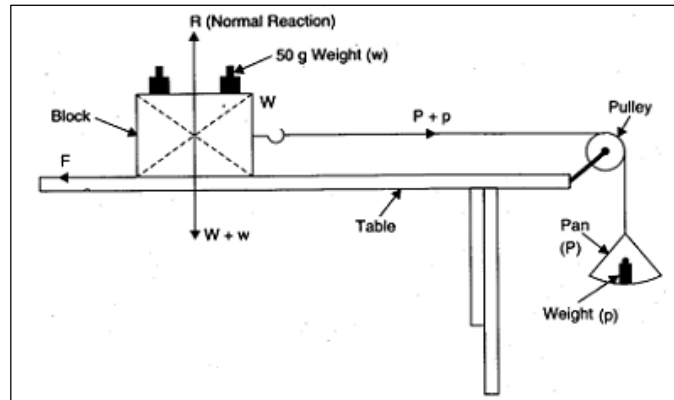

Fig.13.2 Study of force for sliding

**VIII. Requires Recourses/Apparatus/Equipment with Specifications**

Sr. No.	Particulars	Specification	Quantity	Remark
1	Adjustable inclined plane	Wooden make with protractor fitted to it for measurement of angle of inclination. A frictionless pulley fitted at its free end	One for Group of 4to5 students	
2	Block	Hollow wooden block with bottom fitted with different material sheets such aluminum, brass, copper, plywood etc.	One each	
3	Standard weight	Measuring 100,500and 1000gms a fractional weight box	Two each	
4	Inextensible string with pan	1m long tied to the block at one end and pan at the other	One for each block	

**IX. Precautions to be followed**

1. The plane should be clean and smooth
2. The load and effort should move slowly.
3. The thread should be free from knots.
4. Pulley should be frictionless.
5. Efforts must be applied gradually.
6. String should be knot free.

**X. Procedure**

1. Keeps the plane horizontal using spirit level.
2. Weight the box place the box on the surface of the frictional apparatus.

3. Attach a piece of string to the box and pass it over the pulley. At the other end of the string attach a pan.
4. Put some weight in the pan gently till the box is just at the point of motion. Note down the total weight in the pan.
5. Total hanging mass and its weight (P) and total mass of block with weight (w).
6. Add some weight in the box and repeat the above steps.
7. Take at least 6 readings of weight in box and the weights in pan.
8. Repeat the process with different set of surface in contact.

**XI. Observations Table**

Sr. No.	Surface in contact	Load W (N)	Effort P (N)	Force of Friction F=P(N)	Normal Reaction R=W(N)	Coefficient of Friction $\mu=F/R$	Average $\mu$
1							
2							
3							
4							
5							
6							

**XII. Results**

1. The average value of coefficient of static friction for surface in contact.
  - a).....and.....( $\mu$ )=.....

**XIII. Interpretation of results**

Coefficient of friction for a pair of surfaces in contact..... and ..... is more/less than that for.....and.....

**XIV. Conclusions and Recommendations**

.....  
 .....  
 .....

**XV. Practical Related Questions**

Note: Below given are few sample questions for reference. Teachers must design more such questions so as to ensure the achievement of identified CO. Write answers of minimum three questions.

1. Write any four field application of friction on horizontal surface.
2. Give laws of friction.
3. Give the difference between static friction and dynamic friction.
4. Weather the coefficient of friction will remain same for motion in reverse direction.





**XVII. Suggested Assessment Scheme**

Performance Indicators		Weightage (%)
<b>Process related: 15 Marks</b>		<b>60 %</b>
1	Handling and setting of the apparatus.	5 %
2	Proper determination and applying of effort.	15 %
3	Observation of motion.	10 %
4	Calculation of parameters concerned.	10 %
5	Determination of coefficient of friction.	15 %
6	Working in team.	5 %
<b>Product related: 10 Marks</b>		<b>40 %</b>
1	Error estimation.	5 %
2	Interpretation of result and graph.	10 %
3	Conclusion and Recommendation.	10 %
4	Answer to the practical related questions.	10 %
5	Submission of report in time.	5 %
<b>Total: 25 Marks</b>		<b>100 %</b>

Marks Obtained			Dated sign of Teacher
Process Related(15)	Product Related(10)	Total(25)	

## **Practical No. 14: Determine coefficient of friction using friction apparatus for given block on horizontal plane**

### **I. Practical Significance**

Friction is defined as resistive force offered by the surfaces that are in contact. When we kick a football it rolls for some distance and after that it stops after rolling for some time. This is because of the friction force between the ground and the ball. In this case force that is acting opposite to the motion of the ball and stops the ball is called the friction. Due to friction human can easily walk on surface without slipping. When a body is dragged along the rough plane friction force is more as compare to smooth surface because there is less interlocking between smooth surfaces Friction is very helpful in our daily activities like walking, running. Hence life would be very difficult without friction.

### **II. Industry/Employer Expected Outcomes**

Student will be able to apply the knowledge of frictional forces in automobile industries (braking system brings the vehicle to a stop). In construction industries (While making roads, runways and highways) etc.

### **III. Course Level Learning Outcome(s)**

CO4-Apply the laws of friction in the given situation.

### **IV. Laboratory Learning Outcome(s)**

Verify laws of forces related to forces.

### **V. Relevant Affective Domain related Outcome(s)**

- a. Follow safety practices and precautions.
- b. Demonstrate working as a leader/a team member.
- c. Maintain tools and equipment.

### **VI. Relevant Theoretical Background**

When there is a motion or tendency of motion between two surfaces in contact the Friction exists. The frictional force is opposite to the motion. In some practical situations the friction is required to reduce using lubrication. When the force causes the motion increases, the frictional force is also increased proportionately. Hence when the both are at the point of motion the frictional force is Maximum.

This friction is known as Limiting Friction. Normal Reaction(R): The reaction which is right angle to the plane of motion is called as normal reaction. Coefficient of friction ( $\mu$ ): Is defined as ratio of limiting friction to normal reaction. The frictional force also depends on the type of relative motion between the two surfaces in contact. The motion can be either sliding or rolling. On the basis of motion, the friction is referred as either a sliding or rolling friction.

**VII. Actual diagram used in laboratory with equipment specifications.**

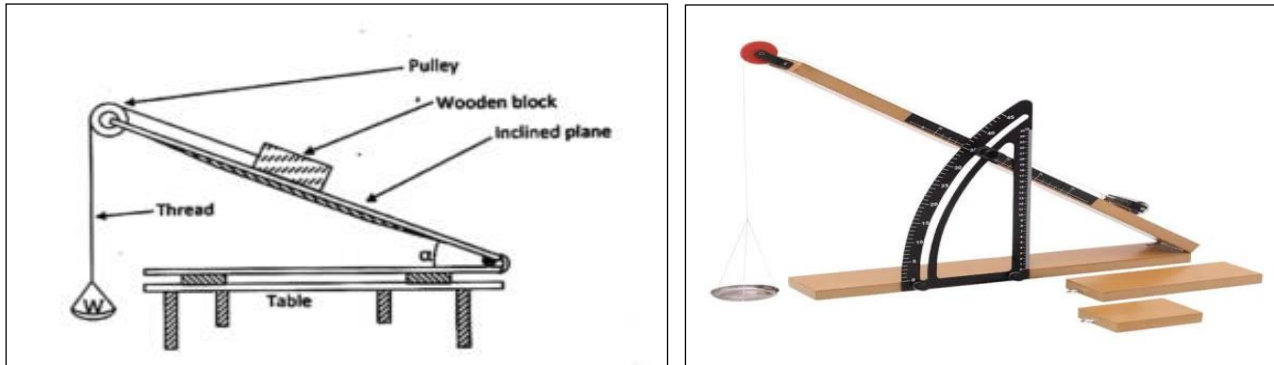

**Fig.14.1 Study of Motion on Inclined Plane**

**VIII. Requires Recourses/Apparatus/Equipment with Specifications**

Sr. No.	Particulars	Specification	Quantity	Remark
1	Adjustable inclined plane	Wooden make with protractor fitted to it for measurement of angle of inclination. A frictionless pulley fitted at its free end	One for Group of 4to5 students	
2	Block	Hollow wooden block with bottom fitted with different material sheets such aluminum, brass, copper ,plywood etc	One each	
3	Standard weight	Measuring 100,500and 1000gms a fractional weight box	Two each	
4	Inextensible string with pan	1m long tied to the block at one end and pan at the other	One for each block	

**IX. Precautions to be followed**

1. The plane should be clean and smooth
2. The load and effort should move slowly.
3. The thread should be free from knots.
4. Pulley should be frictionless.
5. Efforts must be applied gradually
6. String should be knot free.

**X. Procedure**

1. Place the Apparatus on table and make sure that base of the inclined plane is at horizontal surface.
2. Bring the inclined plane to the horizontal position so that the angle of inclination is zero. After that set the apparatus at desired angle.
3. Put a block on surface whose co-efficient of friction is required to be found, at the lower end of inclined plane connect the block with a string which will pass over the frictionless pulley connect the pan to it.
4. Put a limiting value of weight which will cause a uniform upward sliding of the surface block. Record angle, weight of pan as (P) weight of box and weight in box (W).
5. Increase the inclination angle, fixed value of weight pan and vary the weight in box place on surface so that the minimum value of weight in the box may cause uniform motion of the box down the plane Record angle, Total weight of pan as (P) weight of box and weight in box (W).
6. Repeat the above steps for box with different surface.

**XI. Observations Table**

Sr. No.	Surface in contact	Inclination of plane	Load W (N)	Effort P (N)	Sin $\theta$	Cos $\theta$	Coefficient of Friction $\mu$	Average $\mu$
1								
2								
3								
4								
5								
6								

**Draw FBD**

a) Body just sliding down the inclined plane.

b) Body just sliding up the inclined plane.

**Sample Calculation.**

a) **Body just sliding down the inclined plane.**

$$\mu = W \sin\theta - P / W \cos\theta$$

b) **Body just sliding up the inclined plane.**

$$\mu = -P - W \sin\theta / W \cos\theta$$

**XII. Results**

1. The average value of coefficient of static friction for surface in contact.

a).....and.....( $\mu$ )=.....  
.....  
.....

**XIII. Interpretation of results**

Friction depends on the nature of surface in contact and independent on area of contact

**XIV. Conclusions and Recommendations**

.....  
.....  
.....

**XV. Practical Related Questions**

Note: Below given are few sample questions for reference. Teachers must design more such questions so as to ensure the achievement of identified CO. Write answers of minimum three questions.

1. Define Coefficient of friction. Give laws of friction.
2. What is limiting friction?
3. List out the factors affecting friction.
4. State relation between coefficient of friction and angle of friction.
5. Give reason. In rainy season the moving vehicles skid on the road.
6. State advantages and disadvantages of friction.

**Space for answers**

.....  
.....  
.....  
.....





**XVII. Suggested Assessment Scheme**

Performance Indicators		Weightage (%)
<b>Process related: 15 Marks</b>		<b>60 %</b>
1	Handling and setting of the apparatus.	5 %
2	Proper determination and applying of effort.	15 %
3	Observation of motion.	10 %
4	Calculation of parameters concerned.	10 %
5	Determination of coefficient of friction.	15 %
6	Working in team.	5 %
<b>Product related: 10 Marks</b>		<b>40 %</b>
1	Error estimation.	5 %
2	Interpretation of result and graph.	10 %
3	Conclusion and Recommendation.	10 %
4	Answer to the practical related questions.	10 %
5	Submission of report in time.	5 %
<b>Total: 25 Marks</b>		<b>100 %</b>

Marks Obtained			Dated sign of Teacher
Process Related(15)	Product Related(10)	Total(25)	

## Practical No. 15: Verify centroid of plane figure of given dimensions by making simple paper model

### I. Practical Significance

We use various types of shapes, lamina, and composite bars/wires in the constructions, in machines and mechanisms for different purposes. Specific shape is chosen for cross section of a beam, column and other structural member. One of the most important geometric property of the shapes is center of gravity or centroid. The plane figure like circle triangle square has only area, but no mass. The centre of area of plane figure is known as centroid.

### II. Industry/Employer Expected Outcomes

Apply the principles of engineering mechanics to find out centroid of different structural cross-section such as Beam, Column, Dam and Retaining wall etc.

### III. Course Level Learning Outcome(s)

CO5- Determine the centroid/centre of gravity of the structural elements of having specific shape and size.

### IV. Laboratory Learning Outcome(s)

Apply the concept of centroid for given objects.

### V. Relevant Affective Domain related Outcome(s)

- Follow safety practices and precautions.
- Demonstrate working as a leader/a team member.
- Maintain tools and equipment.

### VI. Relevant Theoretical Background

**Centre of gravity:** The centre of gravity of a body is that point through which the resultant of the system of parallel forces formed by the weights of all the particles of the body passes. for all positions of the body.

**Centre of Mass:** The point at which the whole mass of a body is supposed to be concentrated is known as centre of mass.

**Centroid:** Is is the point at which whole area of the body is supposed to be concentrated.

### VII. Actual diagram used in laboratory with equipment specifications.

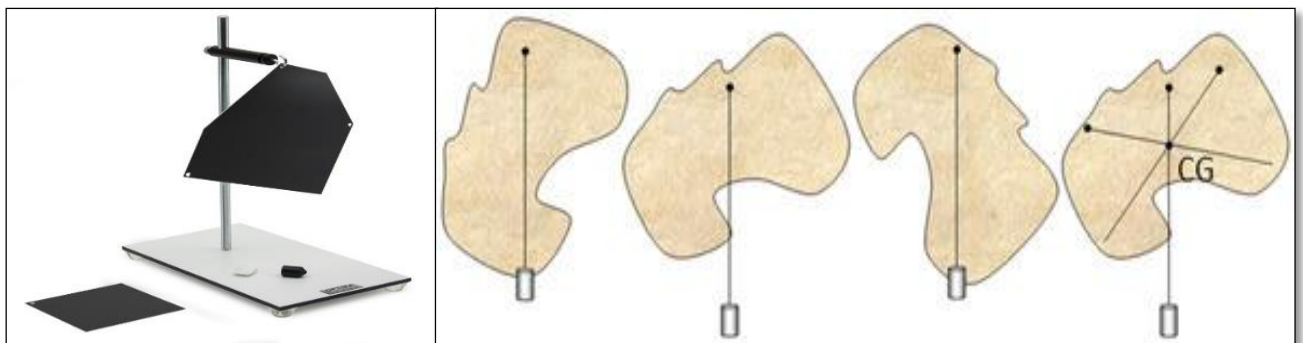

Fig.15.1 Step wise location of centroid with the help of centre of mass

**VIII. Requires Recourses/Apparatus/Equipment with Specifications**

Sr. No.	Particulars	Specification	Quantity	Remark
1	Sheet of paper / Hardboard		01 for each shape	
2	Scissor/cutter		01 for batch of 3 to4 students	
3	Plumb bob with string		01 for batch of 3 to4 students	
4	Marker pen		01 for batch of 3 to4 students	

**IX. Precautions to be followed**

- 1 Line should be connected to each other accurately.
- 2 Drawing errors should be reduced to minimum so as to get correct results

**X. Procedure**

1. Draw any shape on sheet of hard board. And mark holes on a Shape.
2. Hang that shape on a peg through the desire hole.
3. Hang a plumb bob and mark plumb line with marker.
4. Repeat same procedure for other holes.
5. Mark the point of intersection of these lines this point gives the centroid of that lamina by experimentally.
6. Also calculate the center of gravity of that plane lamina by analytically.

**XI. Observations Table**

Sr. No.	Shape	Dimensions (mm)			X-Coordinate(mm)	Y-Coordinate(mm)
1	Square					
2	Rectangle					
3	Triangle					
4	Circle					
5	Semicircle					
6	Trapezium					

**XII. Results**

1. Centroid of Square =
2. Centroid of Rectangle =







**XVII. Suggested Assessment Scheme**

Performance Indicators		Weightage (%)
<b>Process related: 15 Marks</b>		<b>60 %</b>
1	Handling of different geometrical shapes.	5 %
2	Keeping the plumb line vertical.	10%
3	Marking of line on plane lamina.	10 %
4	Determination of centroid of geometrical shapes.	10 %
5	Analytical calculation of centroid.	20 %
6	Working in team.	5 %
<b>Product related: 10 Marks</b>		<b>40 %</b>
1	Error estimation.	5 %
2	Interpretation of result and graph.	10 %
3	Conclusion and Recommendation.	10 %
4	Answer to the practical related questions.	10 %
5	Submission of report in time.	5 %
<b>Total: 25 Marks</b>		<b>100 %</b>

Marks Obtained			Dated sign of Teacher
Process Related(15)	Product Related(10)	Total(25)	