

SCHEME : K

Name : _____
Roll No. : _____ Year : 20__ 20__
Exam Seat No. : _____

LABORATORY MANUAL FOR MECHANICAL ENGINEERING MATERIALS (313317)

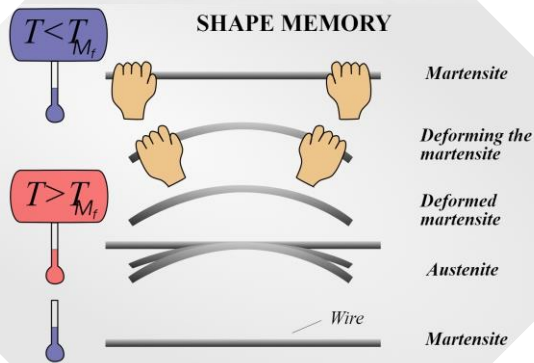

MECHANICAL ENGINEERING GROUP



**MAHARASHTRA STATE BOARD OF
TECHNICAL EDUCATION, MUMBAI**
(Autonomous) (ISO 9001: 2015) (ISO/IEC 27001:2013)

VISION

To ensure that the Diploma level Technical Education constantly matches the latest requirements of Technology and industry and includes the all-round personal development of students including social concerns and to become globally competitive, technology led organization.

MISSION

To provide high quality technical and managerial manpower, information and consultancy services to the industry and community to enable the industry and community to face the challenging technological & environmental challenges.

QUALITY POLICY

We, at MSBTE are committed to offer the best in class academic services to the students and institutes to enhance the delight of industry and society. This will be achieved through continual improvement in management practices adopted in the process of curriculum design, development, implementation, evaluation and monitoring system along with adequate faculty development programmes.

CORE VALUES

MSBTE believes in the following:

- Skill development in line with industry requirements.
- Industry readiness and improved employability of Diploma holders.
- Synergistic relationship with industry.
- Collective and Cooperative development of all stake holders.
- Technological interventions in societal development.
- Access to uniform quality technical education.

A Practical Manual for

Mechanical Engineering Materials

(313317)

Semester– (III/IV)
“K-SCHEME”

**(Diploma in Mechanical/ Mechatronics/Production
Engineering)
(ME/MK/PG)**

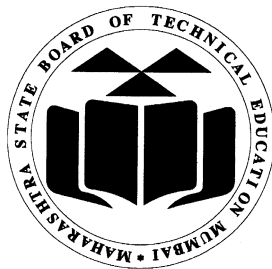

Maharashtra State
Board of Technical Education, Mumbai
(Autonomous) (ISO-9001-2015) (ISO/IEC 27001:2013)



Maharashtra State Board of Technical Education, Mumbai
(Autonomous) (ISO: 9001: 2015) (ISO/IEC 27001:2013)
4th Floor, Government Polytechnic Building, 49, Kherwadi,
Bandra (East), Mumbai – 400051,
(Printed On July, 2024)

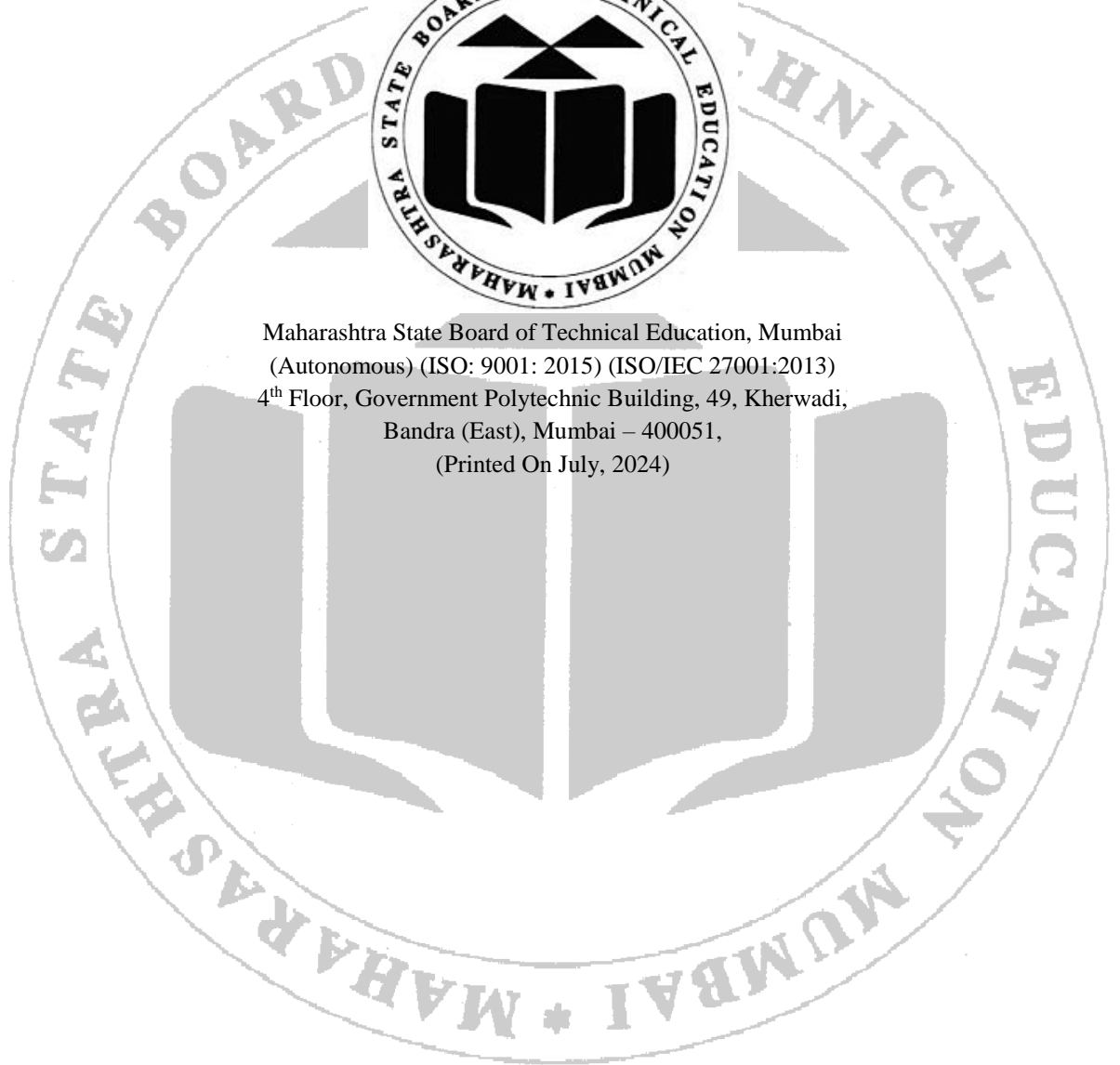

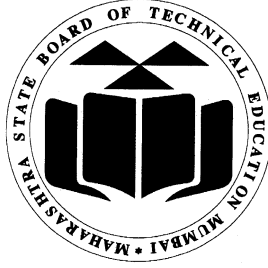

Maharashtra State Board of Technical Education, Mumbai

Certificate

This is to certify that Mr. / Ms. Roll
No..... of Third/Fourth Semester of Diploma in
.....of Institute
.....
(Code.....) has completed the term work satisfactorily in the
course Mechanical Engineering Materials (**313317**) for the academic year
20.....to 20..... as prescribed in the curriculum.

Place: Enrollment No.:
Date: Exam Seat No.:

Course Teacher

Head of the Department

Principal

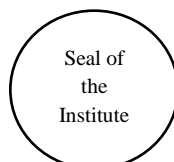

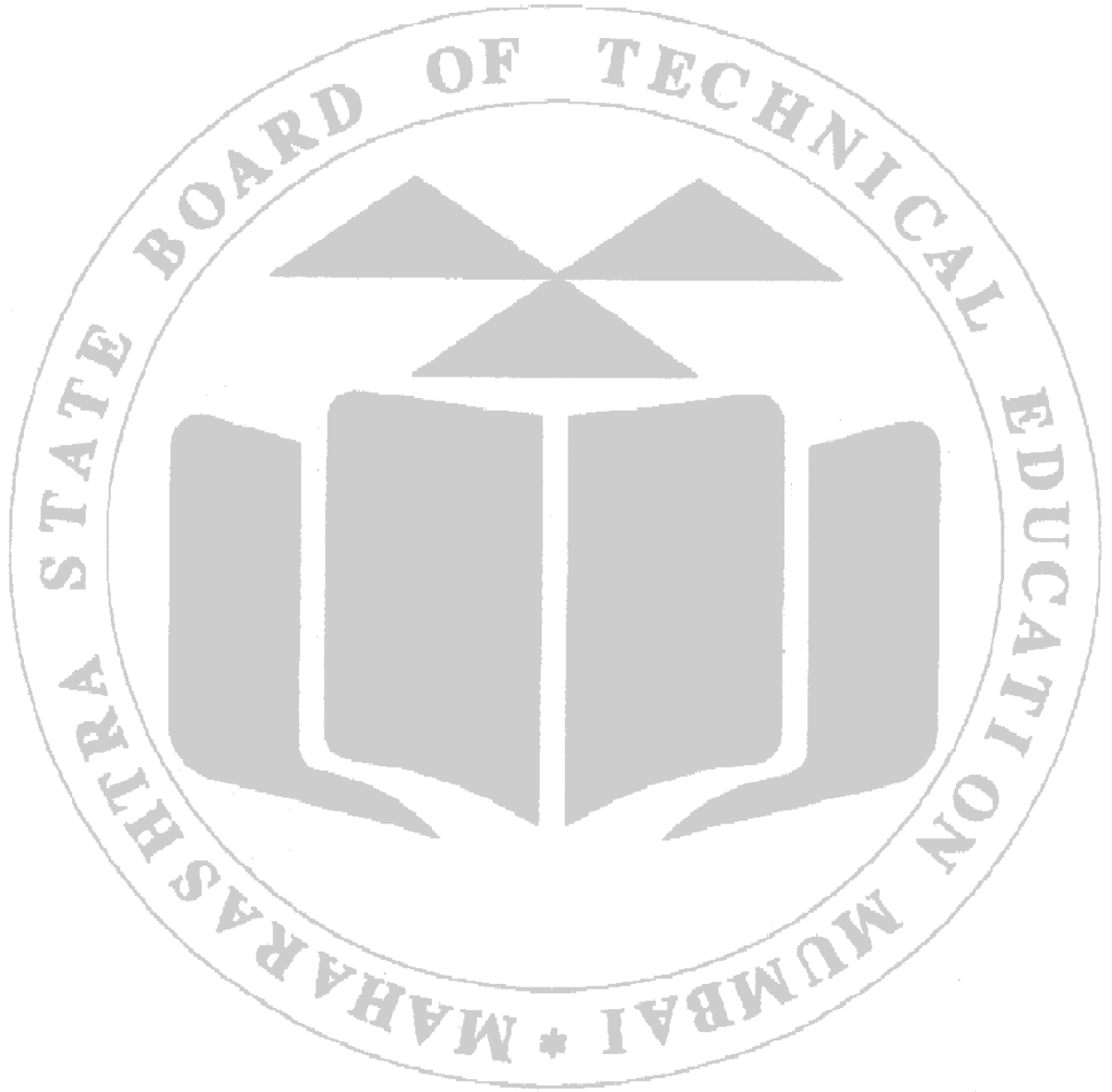

Preface

The primary focus of any engineering laboratory/ field work in the technical education system is to develop the much-needed industry relevant competencies and skills. With this in view, MSBTE embarked on this innovative 'K' Scheme curricula for engineering diploma programmes with National Education Policy 2020 (NEP2020) and outcome-based education as the focus and accordingly, relatively large amount of time is allotted for the practical work. This displays the great importance of laboratory work making each teacher; instructor and student to realize that every minute of the laboratory time need to be effectively utilized to develop these outcomes, rather than doing other mundane activities. Therefore, for the successful implementation of this outcome-based curriculum, every practical has been designed to serve as a '*vehicle*' to develop this industry identified competency in every student. The practical skills are difficult to develop through 'chalk and duster' activity in the classroom situation. Accordingly, the 'I' scheme laboratory manual development team designed the practical to *focus* on the *outcomes*, rather than the traditional age old practice of conducting practical to 'verify the theory' (which may become a byproduct along the way).

This laboratory manual is designed to help all stakeholders, especially the students, teachers and instructors to develop in the student the pre-determined outcomes. It is expected from each student that at least a day in advance, they have to thoroughly read through the concerned practical procedure that they will do the next day and understand the minimum theoretical background associated with the practical. Every practical in this manual begins by identifying the competency, industry relevant skills, course outcomes and practical outcomes which serve as a key focal point for doing the practical.

This manual also provides guidelines to teachers and instructors to effectively facilitate student-centered lab activities through each practical exercise by arranging and managing necessary resources in order that the students follow the procedures and precautions systematically ensuring the achievement of outcomes in the students.

With the advances made in the field of material science, millions of materials are now available to cater to various needs of mankind. These needs and service conditions dictate the properties to be developed in the materials. Therefore the subject Mechanical Engineering Materials has attracted a lot of attention. Materials like ferrous and nonferrous metals, polymers, ceramics and composites are widely used in variety of engineering applications. This course deals with these materials along with advance materials, their metallurgical considerations, heat treatment processes, structure-property relationship and applications.

The Practical manual development team wishes to thank MSBTE who took initiative in the development of curriculum and implementation and also acknowledge the contribution of individual course experts who have been involved in laboratory manual as well as curriculum development (K scheme) directly or indirectly.

Although all care has been taken to check for mistakes in this laboratory manual, yet it is impossible to claim perfection especially as this is the first edition. Any such errors and suggestions for improvement can be brought to our notice and are highly welcome.

Lab Manual Development Team

Programme Outcomes (POs) to be achieved through Practical of this Course

Following POs are expected to be achieved through the practicals of the (Mechanical Engineering Materials) course.

PO1. Basic and Discipline specific knowledge: Apply knowledge of basic mathematics, science and engineering fundamentals and engineering specialization to solve the mechanical engineering problems.

PO 2. Problem analysis: Identify and analyses well-defined mechanical engineering problems using codified standard methods.

PO 3. Design/ development of solutions: Design solutions for well-defined technical problems and assist with the design of systems components or processes to meet specified needs in mechanical engineering.

PO 4. Engineering Tools, Experimentation and Testing: Apply modern mechanical engineering tools and appropriate technique to conduct standard tests and measurements.

PO 5. Engineering practices for society, sustainability and environment: Apply appropriate technology in context of society, sustainability, environment and ethical practices.

PO 6. Project Management: Use engineering management principles individually, as a team member or a leader to manage projects and effectively communicate about well-defined engineering activities in diverse and multidisciplinary fields.

PO 7. Life-long learning: Ability to analyze individual needs and engage in updating in the context of technological changes in mechanical engineering.

List of Industry Relevant Skills-

The following industry relevant skills of the competency 'for mechanical engineers working in industries where materials play a crucial role, such as automotive, aerospace, energy, manufacturing, and consumer goods' are expected to be developed in you by undertaking the practical of this laboratory manual.

1. Use relevant hardness measuring instruments of machine components.
2. Select the relevant measuring instruments for heat treatment machine components.
3. Measure the hardness of ferrous and non-ferrous material.
4. Measure strength of plastics and rubber.
5. Proficiency in conducting and interpreting results from various material testing techniques such as hardness testing.
6. Ability to characterize materials using techniques such as microscopy (optical, electron, atomic force).
7. Skill in analyzing material failures to determine the root cause, whether it's due to mechanical, thermal, or chemical factors, and proposing solutions to prevent future failures.
8. Knowledge of composite materials, including their properties and applications in industries such as aerospace, automotive, and construction

9. Knowledge of surface modification techniques such as surface hardening and surface finishing to improve material performance and functionality.
10. Understanding of materials recycling processes and sustainable material choices to minimize environmental impact and promote circular economy principles.
11. Capacity to collaborate with professionals from other disciplines such as civil engineering, electrical engineering, and materials science to tackle complex engineering challenges effectively.

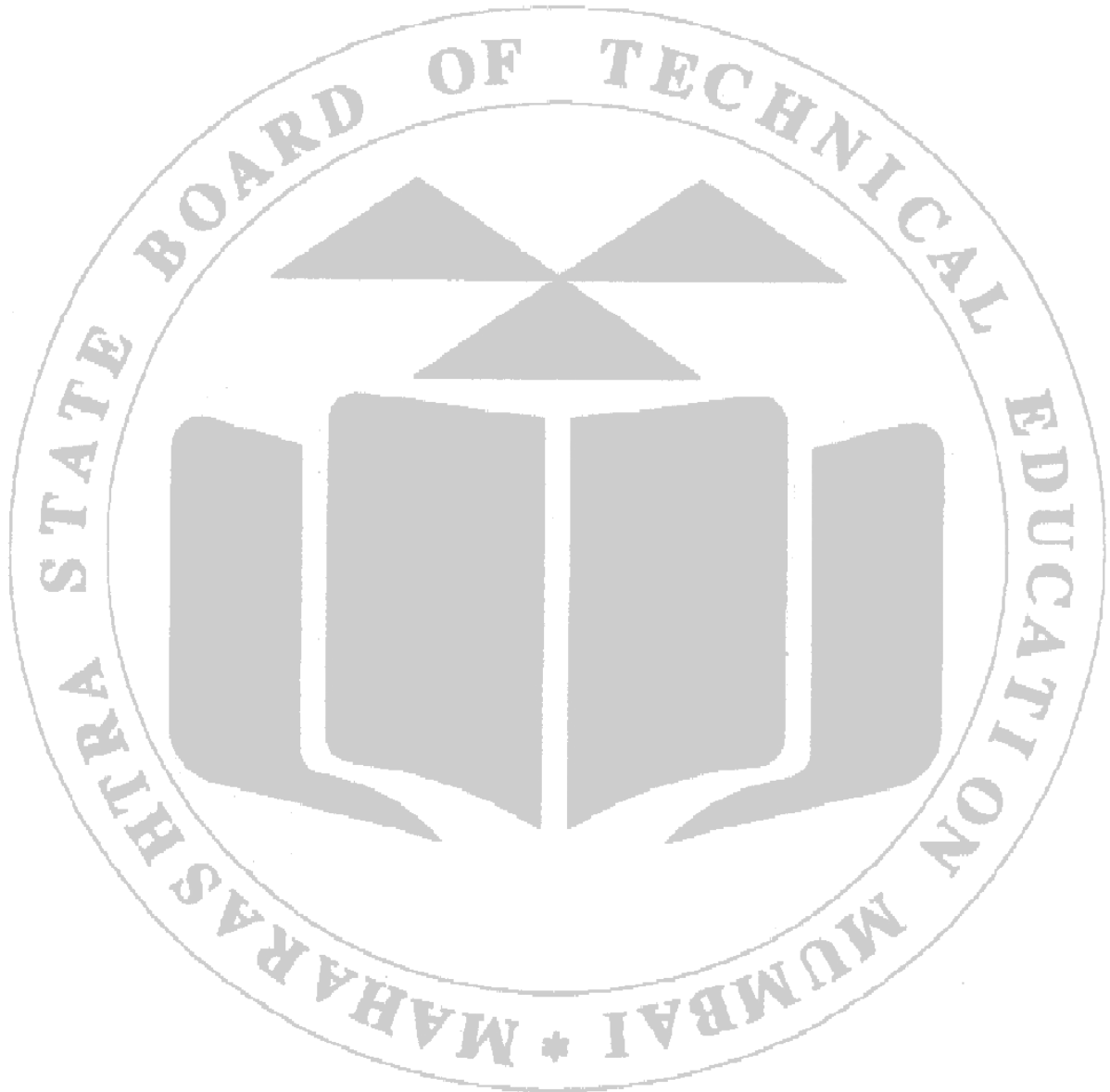

Practical- Course Outcome matrix**Course Outcomes (COs)**

- CO1 - Select suitable material(s) based on desired properties according to application.
 CO2 - Choose relevant alloy steel & Cast iron for mechanical components.
 CO3 - Select relevant nonferrous & powder material components for the engineering application.
 CO4 - Select relevant nonmetallic & Advanced material for the engineering application.
 CO5 - Use relevant heat treatment processes in given situations.

S. No.	Laboratory Practical Titles	CO 1.	CO 2.	CO 3.	CO 4.	CO 5.
1	*Specimen preparation of a given material for microscopic examination.	√	-	-	-	-
2	*Interpretation of microstructure of steels and alloy steels using metallurgical microscope on standard specimens.	√	-	-	-	-
3	*Hardness testing on Brinell Hardness tester of given sample material.	√	-	-	-	-
4	Hardness testing on Rockwell Hardness tester of given sample material.	√	-	-	-	-
5	Hardness testing on relevant hardness testers of given untreated and heat treated Mild Steels.	√	-	-	-	-
6	Hardness testing on relevant hardness testers of given untreated and heat treated Alloy Steels.	√	-	-	-	-
7	*Microstructure of cast iron using metallurgical microscope on standard specimens.	√	√	-	-	-
8	Hardness testing on relevant hardness testers of given Copper and Brass specimens.	√	-	√	-	-
9	Hardness testing on relevant hardness testers of given Aluminium specimens.	√	-	√	-	-
10	*Adhesive strength determination of cellophane tape and duct tape using a relevant peel tester.	-	-	√	-	-
11	Adhesive strength determination of scotch tape, electrical tape and masking tape using relevant peel testers.	-	-	√	-	-
12	*Identification of different types of plastics using flame tests.	-	-	√	-	-
13	*Identification of behavior of the shape-memory alloy as a function with regards to temperature using High-temperature oven or electrical current.	-	-	-	√	-
14	*Comparison of hardness of mild steel using quenching mediums like oil, water & brine in a muffle /box type furnace.	√	-	-	-	√

S. No.	Laboratory Practical Titles	CO 1.	CO 2.	CO 3.	CO 4.	CO 5.
15	Comparison of hardness of alloy steel using quenching mediums like oil, water & brine in a muffle /box type furnace.	√	-	-	-	√
16	Comparison of Ancient Indian material development processes with recent processes. (Compare any two)	√	√	√	√	√

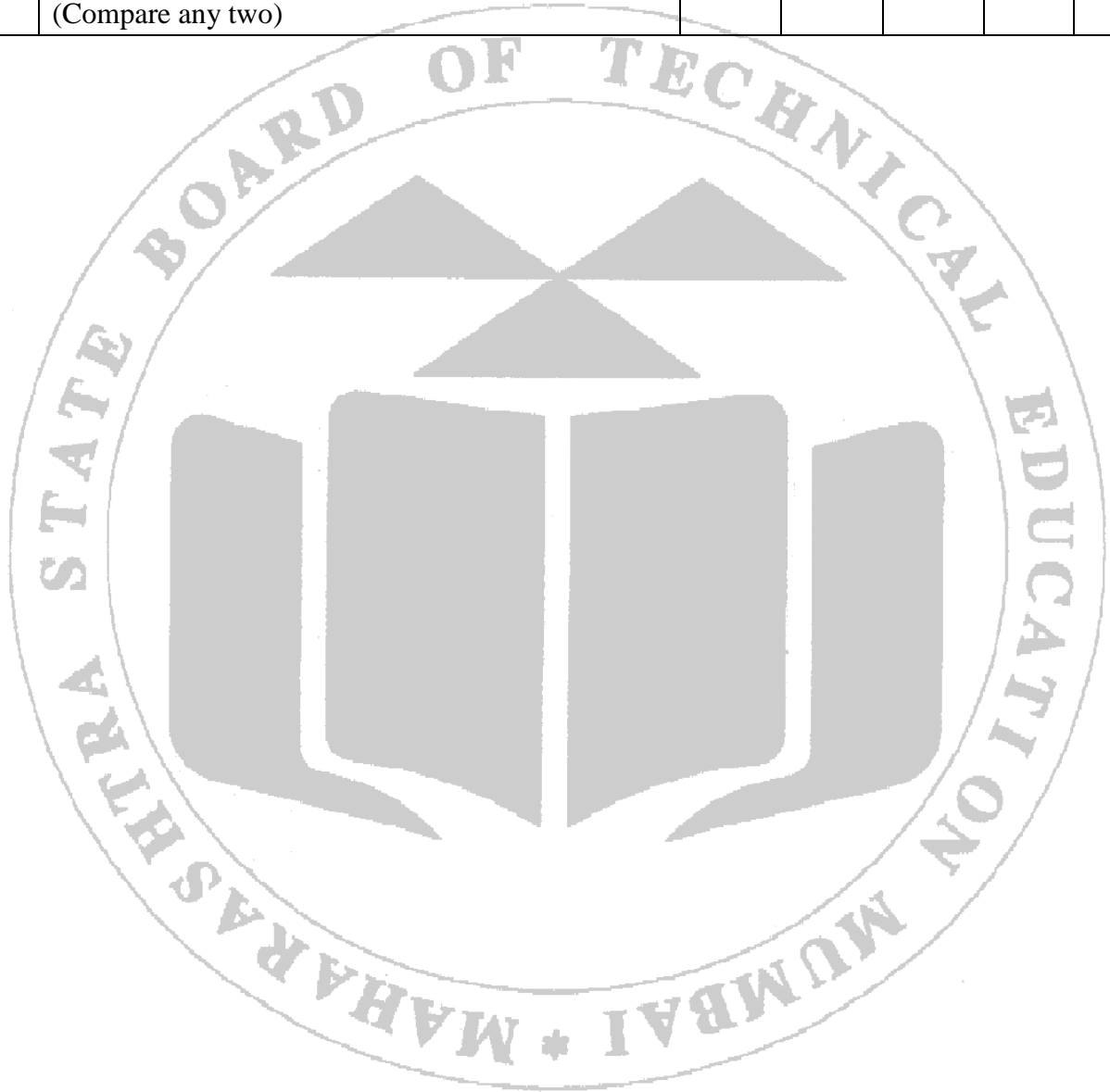

Guidelines to Teachers

1. **Teacher need to ensure that a dated log book** for the whole semester, apart from the laboratory manual is maintained by every student which s/he has to **submit for assessment to the teacher** in the next practical session.
2. There will be two sheets of blank pages after every practical for the student to report other matters (if any), which is not mentioned in the printed practical.
3. For difficult practical if required, teacher could provide the demonstration of the practical emphasizing of the skills which the student should achieve.
4. Teachers should give opportunity to students for hands-on after the demonstration.
5. Assess the skill achievement of the students and COs of each unit.
6. One or two questions ought to be added in each practical for different batches. For this teacher can maintain various practical related question banks for each course.
7. If some repetitive information like data sheet, use of software tools etc. has to be provided for effective attainment of practical outcomes, they can be incorporated in Appendix.
8. For effective implementation and attainment of practical outcomes, teacher ought to ensure that in the beginning itself of each practical, students must read through the complete write-up of that practical sheet.
9. During practical, ensure that each student gets chance and takes active part in taking observations/readings and performing practical.
10. Teacher ought to assess the performance of students continuously according to the MSBTE guidelines

Instructions for Students

1. For incidental writing on the day of each practical session every student should maintain a **dated log book** for the whole semester, apart from this laboratory manual which s/he has to **submit for assessment to the teacher** in the next practical session.
2. For effective implementation and attainment of practical outcomes, in the beginning of each practical, students need to read through the complete write-up including the practical related questions and assessment scheme of that practical sheet.
3. Student ought to refer the data books, IS codes, Safety norms, Technical Manuals, etc.
4. Student should not hesitate to ask any difficulties they face during the conduct of practical.

Content Page

List of Practical and Progressive Assessment Sheet

S. No	Laboratory Practical Titles	Page No.	Date of performance	Date of submission	FA PR marks (25)	Dated sign. of teacher	Remarks (if any)
1	*Specimen preparation of a given material for microscopic examination.	1					
2	*Interpretation of microstructure of steels and alloy steels using metallurgical microscope on standard specimens.	10					
3	*Hardness testing on Brinell Hardness tester of given sample material.	20					
4	Hardness testing on Rockwell Hardness tester of given sample material.	31					
5	Hardness testing on relevant hardness testers of given untreated and heat treated Mild Steels.	41					
6	Hardness testing on relevant hardness testers of given untreated and heat treated Alloy Steels.	53					
7	*Microstructure of cast iron using metallurgical microscope on standard specimens.	67					
8	Hardness testing on relevant hardness testers of given Copper and Brass specimens.	76					
9	Hardness testing on relevant hardness testers of given Aluminum specimens.	87					
10	*Adhesive strength determination of cellophane tape and duct tape using a relevant peel tester.	98					
11	Adhesive strength determination of scotch tape, electrical tape and masking tape using relevant peel testers.	106					
12	*Identification of different types of plastics using flame tests.	113					
13	*Identification of behavior of the shape-memory alloy as a function with regards to temperature using High-temperature oven or electrical current.	119					

S. No	Laboratory Practical Titles	Page No.	Date of performance	Date of submission	FA PR marks (25)	Dated sign. of teacher	Remarks (if any)
14	*Comparison of hardness of mild steel using quenching mediums like oil, water & brine in a muffle /box type furnace.	125					
15	Comparison of hardness of alloy steel using quenching mediums like oil, water & brine in a muffle /box type furnace.	134					
16	Comparison of Ancient Indian material development processes with recent processes.	142					

Note: To be transferred to Proforma of CIAAN-2023.

A suggestive list of LLOs is given in the above table. More such LLOs can be added to attain the COs and competency. A judicious mix of minimum 12 or more practical need to be performed, out of which, the practical marked as ‘*’ are compulsory, so that the student reaches the ‘Precision Level’ of Dave’s ‘Psychomotor Domain Taxonomy’ as generally required by the industry.

Practical No.1: Specimen Preparation of a Given Material for Microscopic Examination.

I. Practical Significance

Sample preparation is an essential part of microscopy and there are many techniques that can be used. Incorrect techniques in preparing a sample may result in altering the true microstructure and will most likely lead to erroneous conclusions. The basic sample preparation process consists of sectioning, mounting, coarse & fine grinding, and polishing.

II. Industry/Employer Expected Outcome (s)

This practical is expected to develop the following skills for the industry/Employer 'specimen preparation ensures that microscopic examination can provide valuable insights into the structure and properties of materials, supporting various applications in fields such as materials science, engineering, forensics, and biomedical research'.

III. Course Level Learning Outcome (CO)

CO1 - Select suitable material(s) based on desired properties according to application.

IV. Laboratory Learning Outcome(s)

- Use slitting machine to prepare sample of given dimension.
- Use grinding machine & polishing papers to prepare surface of given sample.

V. Relative Affective Domain related Outcome(s)-

- Demonstrate working as a leader/a team member.
- Maintain tools and equipment.
- Follow ethical Practices.
- Follow safety practices.
- Practice good housekeeping.

VI. Minimum Theoretical Background with diagram (if required)

1. Sectioning:

- **Purpose:** Sectioning involves cutting the sample into thin slices or sections for microscopic examination. This is essential for studying internal structures or features of the material.
- **Techniques:**
 - **Mechanical Sectioning:** Using a specialized cutting tool called a microtome, the sample is sliced into thin sections with precise control over thickness.
 - **Electron Beam Sectioning:** In electron microscopy, samples can be sectioned using a focused ion beam (FIB) to mill away material layer by layer.

2. Mounting:

- **Purpose:** After sectioning, the thin slices of the sample need to be affixed to a support for stability during subsequent preparation steps and examination.
- **Techniques:**

- **Adhesive Mounting:** The sample is typically attached to a glass slide using an adhesive such as glue or resin.
- **Hot Mounting:** For some materials like thermosetting polymers or metals, mounting may involve embedding the sample in a hot thermosetting resin which solidifies around it upon cooling.

3. Grinding

- Grinding is an abrasive machining process that uses a grinding wheel as the cutting tool. The purpose of the grinding step is to remove damage from cutting, planarize the Specimen, and to remove material approaching the area of interest. Grinding removes saw marks and levels and cleans the specimen.
 - **Coarse Grinding:**
 - **Purpose:** Coarse grinding is the initial step in reducing the thickness of the sample slices and removing excess material to bring the sample closer to the desired thickness.
 - **Techniques:**
 - **Abrasive Grinding:** Coarse grinding is usually achieved by using abrasive papers or wheels with progressively finer grit sizes to remove material efficiently.
 - **Fine Grinding:**
 - **Purpose:** Fine grinding follows coarse grinding and further refines the sample surface, reducing scratches and other surface imperfections left by coarse grinding.
 - **Techniques:**
 - **Polishing Abrasives:** Finer abrasives such as diamond paste or alumina suspensions are used in conjunction with polishing cloths or pads to achieve a smooth, uniform surface.
- ### 4. Polishing:
- In metallography and metallurgy, polishing is used to create a flat, defect-free surface for examination of a metal's microstructure under a microscope. Polishing is the process of creating a smooth and shiny surface by rubbing it or using a chemical action, leaving a surface with a significant specular reflection. Polishing is the most important step in preparing a specimen for microstructural analysis. It is the step which is required to completely eliminate previous damage. Surface Polishing removes the artifacts of grinding but very little stock.
 - **Purpose:** Polishing is the final step in sample preparation, producing a mirror-like surface finish suitable for microscopic examination, especially under high magnification.
 - **Techniques:**
 - **Chemical Polishing:** Some materials may undergo chemical polishing, where a chemical solution etches away a thin layer of material to reveal a smooth surface.

- **Mechanical Polishing:** Using polishing compounds and pads, the sample is buffed to a high shine, removing any remaining surface imperfections.

These steps are crucial for preparing samples for microscopic examination, ensuring that the material's structure and features are clearly visible and accurately represented in the resulting images or analyses.

VII. Experimental setup

1. Disc polishing machine



Fig. 1.1 Double disc Polishing machine

2. Sample preparation step

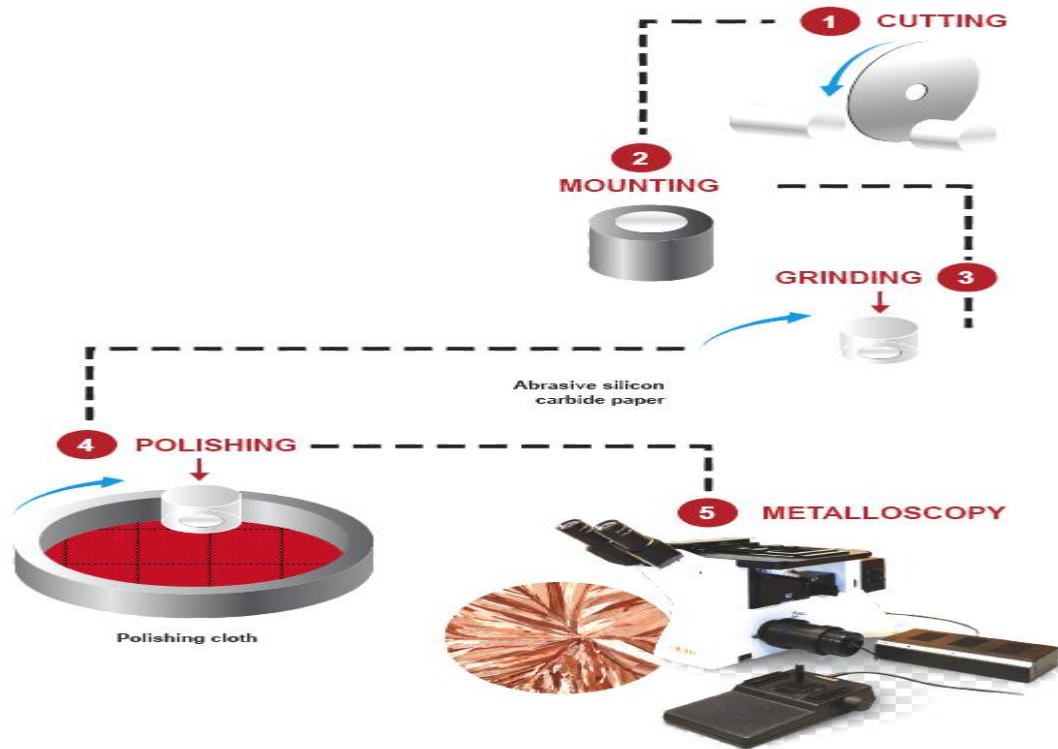

Fig. 1.2 Steps for sample preparation

VIII. Required Resources /Apparatus/Equipment with specification

Sr. No.	Name of Resource	Suggested Specification	Broad	Quantity
1	Given specimen	Carbon/ Alloy steel rod or bar of 25 mm dia. or 25mm x25mm c/s area		1 piece of 25 mm thickness per student
2	Slitting Machine	Slitting machine Specifications: • Capacity: 18 gauge / 1.2mm • Throat Depth: 24 inch(600mm) • Motor: 1 HP, 230V, 50 Hz. • Minimum Slitting Width: 1 inch (25.4mm)		01
3	Polishing Machine Grinding/polishing disc	Double Disk polishing machine. Two independent polishing units mounted on a common MS frame, Disc dia. 200mm, made of Aluminum. Speed continuously variable up to 950RPM. Rating - 0.25 HP single phase 220 Volt A.C. provided with sink and swing type laboratory water tap. Waterproof Formica table top.		01
4	Aluminum oxide abrasive solution	Commercial grade		1 bottle per 10students
5	Emery papers	(80,120,240,400,600,1200) Grades		1 set of Each for 4 students

IX. Precautions to be Followed

- Polishing should be slow, smooth and flat.
- Uniform pressure is applied throughout the polishing.
- When polishing the specimen, hold it with both hands, apply a moderate amount of pressure, and don't let it go. The rough polishing stages (5-25 microns) should take between 1 and 2 minutes each. If you let go of the specimen it may fly, harm you or others in the laboratory

and become damaged forcing you to start over again with coarse grinding - hold it tight and be careful.

- Do not contaminate the polishing wheel; cover the wheel when not in use.
- Do not touch the specimen surface after polishing.
- Metallographic sample preparation involves handling metallic samples for microscopic examination, often in the context of metallurgy or materials science. Here are some important precautions to consider during metallographic sample preparation:
 - Safety Gear: Always wear appropriate personal protective equipment (PPE) such as gloves, safety glasses, and lab coats to protect yourself from potential hazards.
 - Chemical Handling: Handle chemicals used in sample preparation with care, following all safety protocols and instructions provided by manufacturers. Many chemicals used in metallographic sample preparation can be hazardous if not handled properly.
 - Ventilation: Work in a well-ventilated area or use a fume hood when dealing with volatile or toxic chemicals to prevent inhalation of harmful fumes.
 - Machine Safety: When using mechanical equipment such as grinders, polishers, or cutting tools, follow safety guidelines and ensure that guards are in place to prevent accidents.
 - Electrical Safety: If using electrical equipment such as polishing machines, ensure that they are properly grounded to prevent electric shock hazards.
 - Sample Contamination: Take precautions to prevent contamination of samples during preparation. Clean all equipment thoroughly before and after use, and handle samples with clean gloves to avoid introducing foreign particles.
 - Proper Handling: Handle samples with care to avoid damage or distortion. Use soft materials or padding when transferring samples to prevent scratching or marring of surfaces.
 - Correct Techniques: Follow established metallographic sample preparation techniques carefully to ensure accurate and reproducible results. Improper techniques can lead to artifacts or inaccurate observations.

X. Procedure

1. Choose a representative portion of the material that contains the features or structures of interest.
2. Conduct a visual inspection of the sample to identify its surface condition and any contaminants that may need to be removed.
3. Clean the sample surface thoroughly to remove any dirt, grease, or other contaminants that could interfere with microscopy. Use appropriate solvents, such as ethanol or acetone, and clean wipes or brushes.
4. Mount the sample onto a suitable substrate or holder, depending on the microscopy technique. Common mounting methods include adhesive mounting on glass slides for light microscopy or embedding in epoxy resin for electron microscopy.
5. Cut the sample on slitting machine from the bar/rod as per the dimensions
6. Remove the burrs using file or coarse grinding paper.
7. Grind the specimen on emery papers starting from coarse(400) to fine grade (1200)
8. Clean your specimen and hands thoroughly before polishing.
9. Wear safety goggles when using the polishers.
10. Polish the specimen beginning with the 25-micron, nylon cloth polishing station.

11. Turn the water on adjusting to less than one drop per second.
12. Apply a small amount of the aluminum oxide abrasive solution to the polishing cloth.
13. Wash and dry both the specimen and your hands thoroughly, then rinse the specimen.
14. Repeat steps 6 through 9 for the 5-micron stage.
15. Proceed to the final polishing stage (1 micron).
16. The final polishing stage (I-micron) should take between 1/2 and 1 minute
17. Inspect the prepared sample under a microscope or with the naked eye to ensure that the desired surface quality has been achieved and that no artifacts are present.
18. Document the sample preparation process, including details such as sample identification, preparation methods, and any observations made during the process. This documentation is essential for reproducibility and data interpretation.

XI. Results

XII. Interpretation of Results

XIII. Conclusions and Recommendation

XIV. Practical Related Questions

Note: Below given are few sample questions for reference. Teachers must design more such questions so as to ensure the achievement of identified CO.

1. Enlist the steps involved in the preparation of a metallographic sample.
2. Explain Sectioning, Mounting, Coarse Grinding, Fine Grinding and Polishing in the preparation of a metallographic sample.
3. The need of washing and drying of metallographic samples before proceeding from one grinding or polishing operation to the next. Give justification if true or false.
4. Explain the correlation of grade number of the emery paper with its nature.
5. Explain the method for polishing small size sample which cannot be hold properly in the hand.
6. State the precautions to be taken to preserve the polished sample for future use.
7. List the various commercial brands of emery papers.
8. List the different ways of specifying the emery papers.
9. Explain how do the properties of the metallurgical sample (such as hardness and brittleness) influence the preparation techniques used.

[Space for Answer]

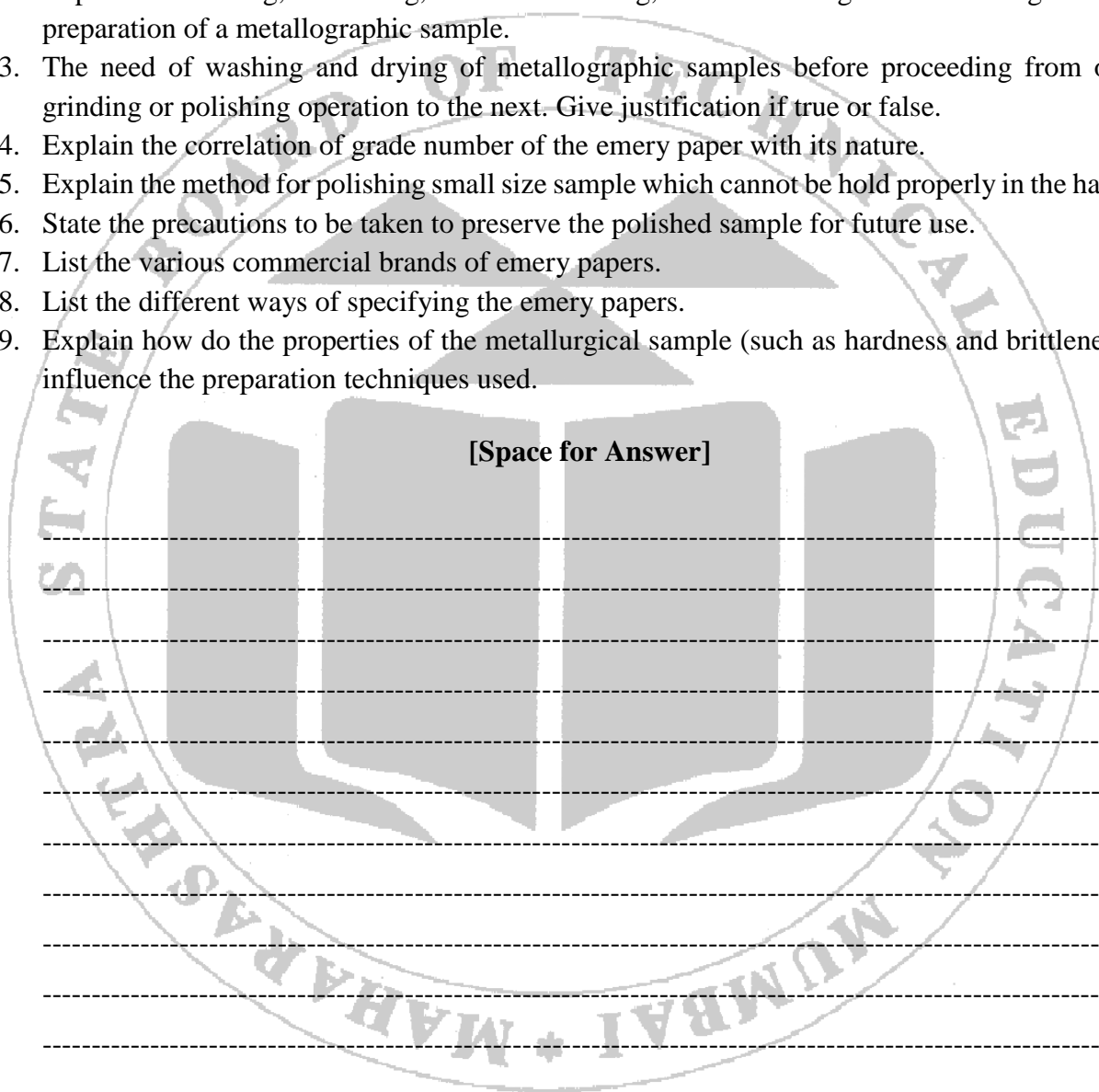

A large, faint watermark of the Maharashtra State Board of Technical Education logo is centered on the page. The logo features a book and a gear, with the text 'MAHARASHTRA STATE BOARD OF TECHNICAL EDUCATION' and 'MUMBAI' around it. Below the watermark, there are several horizontal dashed lines for writing answers.

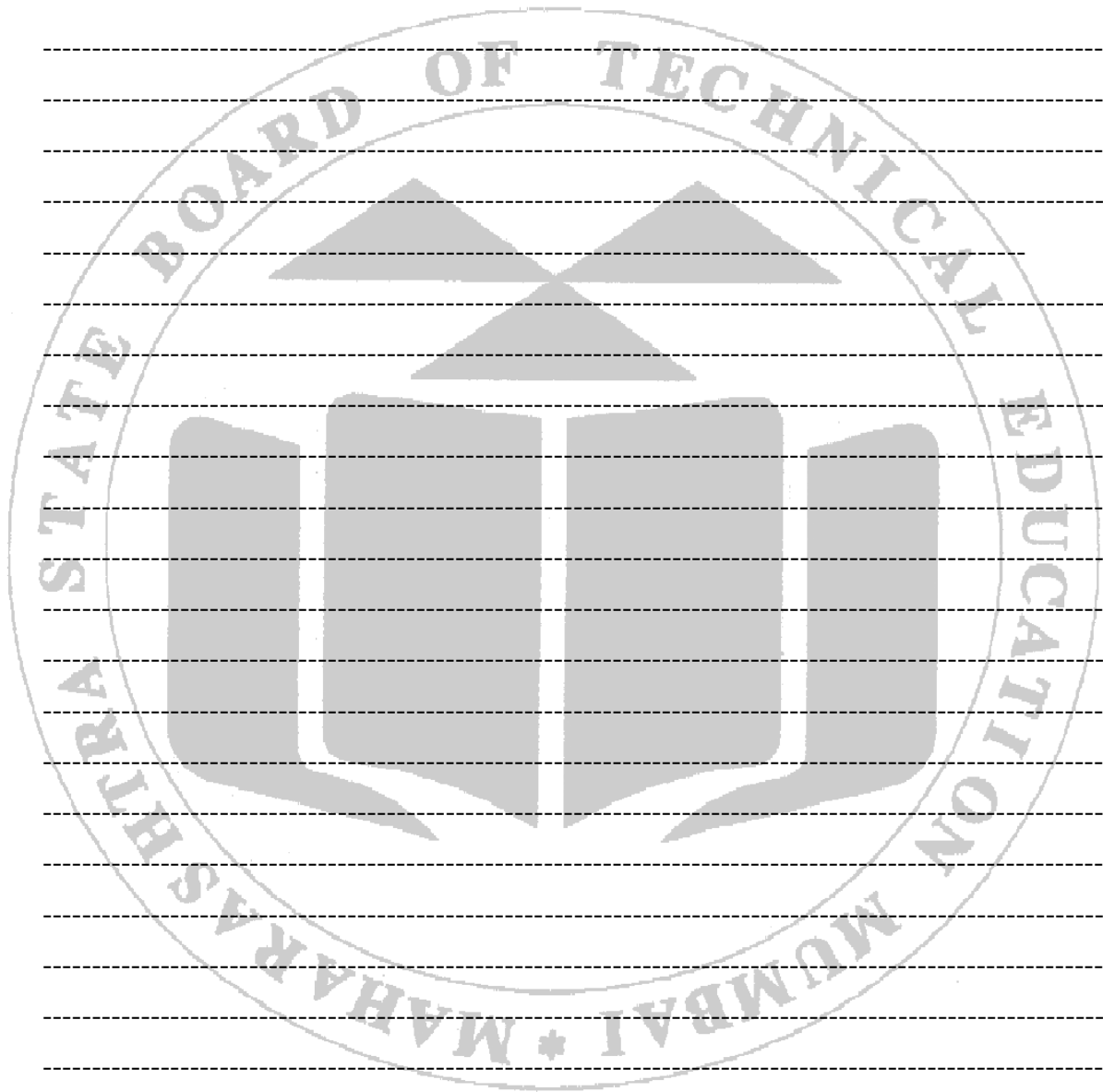

XV. References / Suggestions for Further Reading

- <https://www.youtube.com/watch?v=P4U1AJOKmlU>
- <https://youtu.be/fc8zrgYJCJw?t=75>
- <https://youtu.be/UuHofNW40Yw?t=63>

XVII Rubrics for Assessment Scheme

Performance Indicators		Weightage
Process Related (10 Marks)		(40%)
1	Preparation of experimental set up	10%
2	Cutting of specimen using slitting machine or hack saw	10%
3	Grinding and Polishing of specimen	20%
Product Related (15 Marks)		(60%)
4	Prepared specimen	30%
5	Interpretation of result	10%
6	Conclusions and recommendation	10%
7	Practical related questions	10%
Total (25 marks)		100 %

Marks Obtained			Dated signature of Teacher
Process Related(10)	Product Related(15)	Total (25)	

Practical No. 02: Interpretation of Microstructure of Steels and alloy Steels Using Metallurgical Microscope On standard Specimens.

I. Practical Significance

The microstructure of steel and alloy steels can strongly influence physical properties such as strength, toughness, ductility, hardness, corrosion resistance, high/low temperature behavior or wear resistance. These properties in turn govern the application of these materials in industrial practice. The effects of most industrial processes applied to metals to control their properties can be explained by studying their microstructures. In summary, the interpretation of microstructures of steels and alloy steels using metallurgical microscopy on standard specimens is essential for ensuring quality, optimizing processes, diagnosing failures, advancing research, and meeting regulatory requirements across various industrial sectors

II. Industry/Employer Expected Outcome (s)

This practical is expected to develop the following skills for the industry/Employer

1. Gaining proficiency in the use of metallurgical microscopes, including adjusting magnification, focus, and illumination to observe fine details of the microstructure.
2. Identifying different phases, grain structures, and microstructural features such as ferrite, pearlite, martensite, austenite, bainite, and carbide precipitates.
3. Adhering to safety protocols in the laboratory, including the safe handling of chemicals used in etching and the proper use of equipment.

III. Course Level Learning Outcome (CO)

CO1 - Select suitable material(s) based on desired properties according to application.

IV. Laboratory Learning Outcome(s)

- Use suitable etchant for microscopic examination of given sample.
- Use a metallurgical microscope to observe microstructure of given specimen.
- Interpret the micro structure of given specimen.

V. Relative Affective Domain related Outcome(s)-

- Demonstrate working as a leader/a team member.
- Maintain tools and equipment.
- Follow ethical Practices.
- Follow safety practices.
- Practice good housekeeping.

VI. Minimum Theoretical Background

Structures which are coarse enough to be differentiated by the naked eye or under low magnifications are termed 'macrostructures'. Those which require high magnification to be visible are termed 'microstructures'. Microscopes are required for the examination of the microstructure of the metals. The function of a microscope is to transform an object into an image, which is generally magnified to varying degree. Metals and alloys are polycrystalline, that is, they are composed of crystals commonly referred to as grains. The size, shape, and configuration of the grains within a metal or an alloy are a function of the way in which the metal was produced and used. The metallographic examination of specimens allows the

metallographer to observe and record the crystalline structures and to interpret from them the history of manufacture and use of the material.

Phases in Steel

Ferrite (α -Fe): The BCC structure, soft and ductile, low carbon solubility.

Austenite (γ -Fe): The FCC structure, non-magnetic, can dissolve more carbon than ferrite, stable at high temperatures.

Cementite (Fe_3C): Hard, brittle iron carbide phase, important in pearlite and other structures.

Pearlite: Eutectoid mixture of ferrite and cementite in a lamellar structure.

Martensite: A supersaturated solid solution of carbon in iron, formed by rapid quenching of austenite, very hard and brittle.

Bainite: A mixture of ferrite and cementite, with a microstructure that is finer than pearlite.

Phases and Microstructures in Alloy Steels

Ferrite (α -Fe): BCC structure, soft and ductile, present at room temperature in low-carbon steels.

Austenite (γ -Fe): FCC structure, non-magnetic, stable at high temperatures, important in stainless steels.

Cementite (Fe_3C): Hard and brittle iron carbide, found in pearlite, bainite, and spheroidite.

Martensite: A supersaturated solid solution of carbon in iron, formed by rapid quenching of austenite, very hard and brittle.

Bainite: A fine mixture of ferrite and cementite, formed at temperatures lower than pearlite but higher than martensite.

Pearlite: A eutectoid mixture of ferrite and cementite with a lamellar structure.

Spheroidite: Cementite particles within a ferrite matrix, resulting from prolonged heating at a temperature below the eutectoid temperature.

Etching:

In order to make the grain boundaries visible, after polishing the metal specimens are usually etched. Etching is the selective attack by a chemical reagent that reveals the micro-structural detail of the polished mount. Before etching, the polished specimen is thoroughly washed in running water. Then, the etching is done either by,

- (i) Immersing the polished surface of the specimen in the etching reagent or by
- (ii) Rubbing the polished surface gently with a cotton swab wetted with the etching reagent.

After etching, the specimen is again washed thoroughly and dried. Now, the specimen can be studied under the microscope.

Metals	Etching Reagent	Composition	Remarks
Steel and steel alloys	Nital	11 to 5% Nitric Acid	Carbon steels darkens pearlite, reveals ferrite boundaries; general use for high speed steels; Time: 1 to 60 sec.
		95to 99 Alcohol	
	Picral	4g Picric Acid 100ml Alcohol	Carbon and Low alloy steels, heat treated or not. Time: 5 to 120 sec.
Steel and steel alloys	Ferric Chloride & Hydrochloric Acid	5g FeCl ₃	Reveals structures of austenite and stainless steels
		50g HCl	
		100ml H ₂ O	

VII. Experimental setup (Model)-

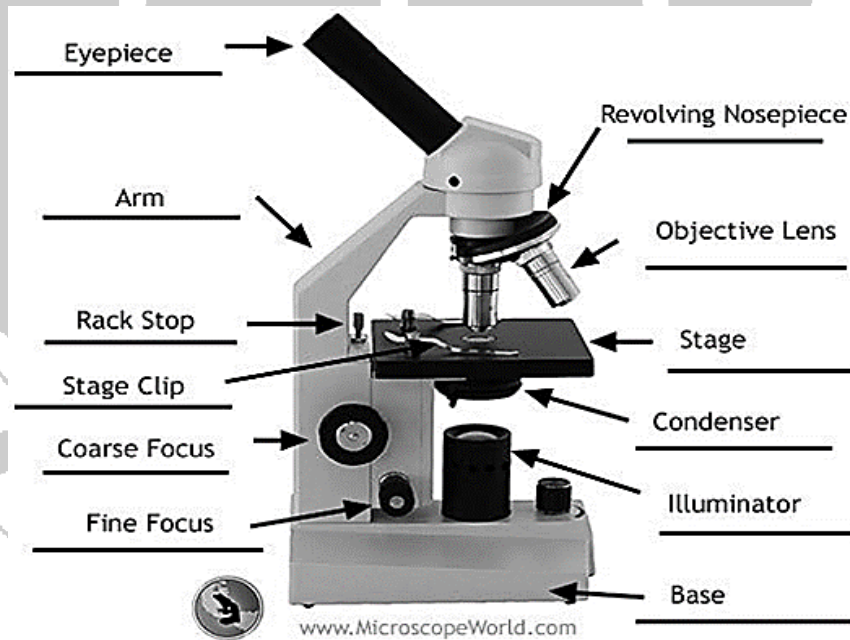

Fig.2.1 Metallurgical Microscope

VIII. Required Resources /Apparatus/Equipment with specification

Sr.No.	Name of Resource	Suggested Broad Specification	Quantity
1	Trinocular Upright Metallurgical Microscope:	Coaxial Body • Body: Trinocular Head inclined at 45-degrees. • Focusing: Both side co-axial focusing knobs. • Nose piece: Quadruple revolving nosepiece with accurate centering & amp; positive click stops.	01
2	Trinocular Inverted Metallurgical Microscope	(Magnification 100X, 200X, 400X &800X) Eyepieces - WF 10X, 20X (Paired) Objectives - M 5x, M 10x, M 20x and M 40x (SL) Stage - Built-in graduated mechanical stage of size 165mm.x180mm. is controlled by convenient low coaxial positioned knobs for easy and smooth scanning of specimen.	01
3	Standard Specimen of plain carbon steel and alloy steel	Rectangular shape 25 mm x 25 c/s area or circular shape 25 mm diameter or as per the availability Low, medium, high carbon steel, Ferritic. Austenitic and Martensitic Stainless steel, HSS, Spring steel	5 specimen of each type

IX. Precautions to be Followed

- Use appropriate personal protective equipment (PPE) such as gloves and goggles when handling etchants.
- Ensure the microscope is properly calibrated and focused to obtain clear images.
- Choose the correct magnification to adequately observe the microstructural features without distortion.
- Capture high-resolution images for detailed analysis and documentation.
- Take images from different areas of the specimen to get a comprehensive view of the microstructure.
- Only screw head should be rotated and the sleeve should not be rotated to avoid excess pressure.

- The screw should be always rotated in one direction to avoid backlash error.

X. Procedure

1. Ensure the metallurgical microscope is properly calibrated and clean.
2. Adjust the lighting to achieve optimal contrast (bright field illumination is commonly used).
3. Turn the lowest-power objective lens into place.
2. Turn the stage height focusing control to position the specimen about half a centimeter under the objective lens.
3. Look through the eyepieces and use the focusing controls (coarse and fine stage height controls) to bring the specimen into appropriate focus.
4. Scan the specimen surface by moving the stage using the stage position controls and select the areas that may warrant more complete study at higher magnification.
5. Turn the higher-power objective into place.
6. Adjust the stage height using the fine control until the specimen comes into sharp focus.
7. Put a drop of oil on specimen surface usually is needed at higher magnification (greater than X2000) to help with focusing.
8. Begin at a low magnification (e.g., 50x or 100x) to get an overview of the microstructure.
9. Increase the magnification (e.g., 500x or 1000x) to examine finer details such as grain boundaries and phase structures.
10. Put a drop of oil on specimen surface usually is needed at higher magnification (greater than X2000) to help with focusing.
11. Capture images of the microstructure at various magnifications for detailed analysis and documentation.
12. Observe the grain size and shape

XI. Observations and calculations

Observations:-

SR. No	The magnification used	Important phases noted	Shape	Size	Color	Distribution of phases
1						
2						
3						

4						
---	--	--	--	--	--	--

XII. Results

XIII. Interpretation of Results

XIV. Conclusions and Recommendation

XV Practical Related Questions

Note: Below given are few sample questions for reference. Teachers must design more such questions so as to ensure the achievement of identified CO.

1. Define Microscopy.

2. State the principle of Metallurgical Microscope.
3. List different etching agents used for specimen preparations.
4. Explain features of microstructures obtained in each case.
5. Explain the significance of grain size in the microstructure of metals. How is grain size measured, and what impact does it have on the mechanical properties of the material.
6. Explain common microstructural features observed in metallurgical samples, such as grain boundaries, phases, inclusions, and precipitates. How do these features relate to the material's properties.
7. Explain effects of over-etching and under-etching on the microstructure of a metallurgical sample? How can these effects be mitigated.
8. Explain the microstructure of low carbon steel.
9. Explain the microstructure of alloy steel.
10. Explain the microstructure of medium carbon steel.
11. List types of microscope.
12. Define etching
13. State the meaning of etching agents.
14. State types of steel with example.

[Space for Answer]

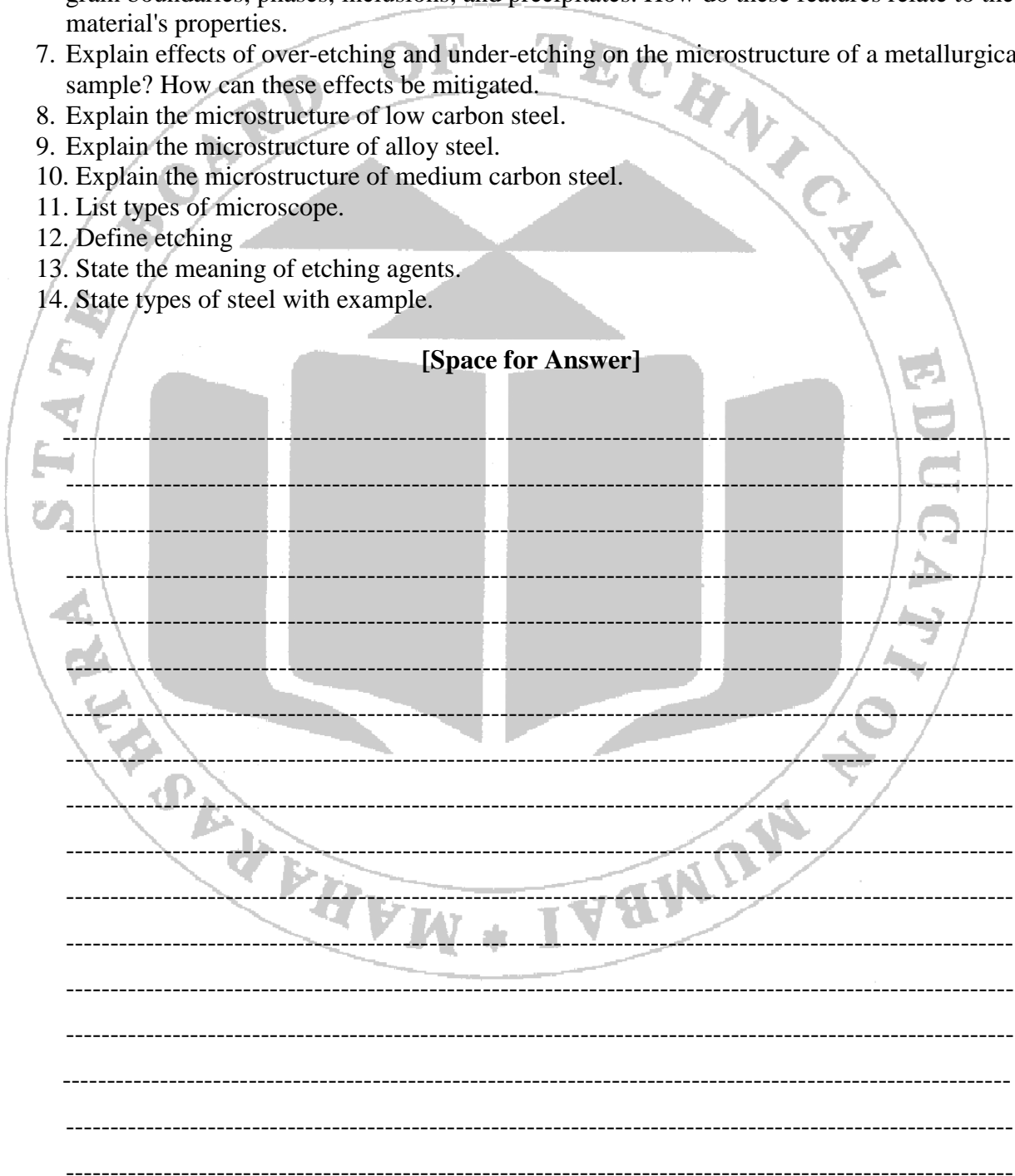

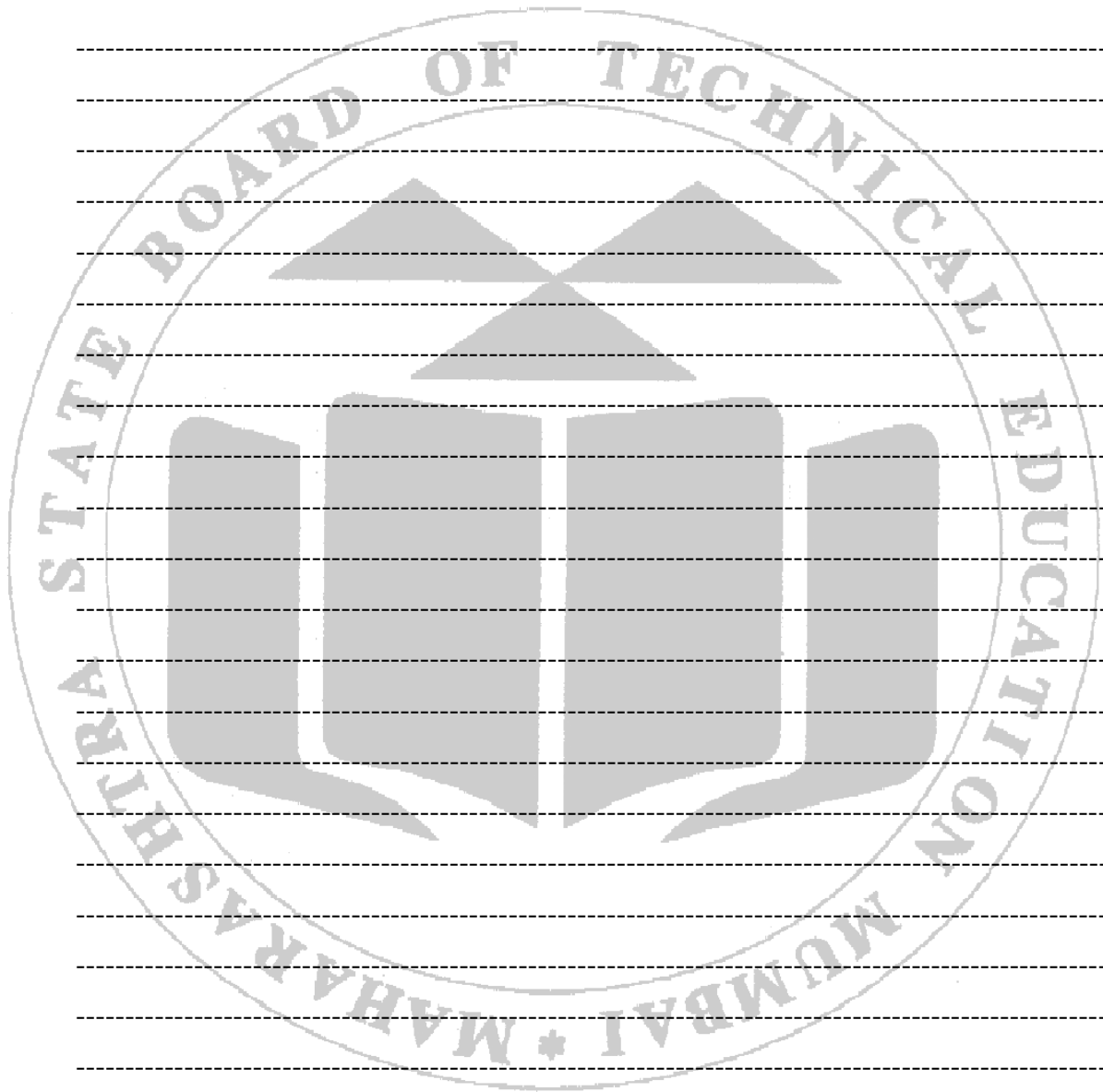

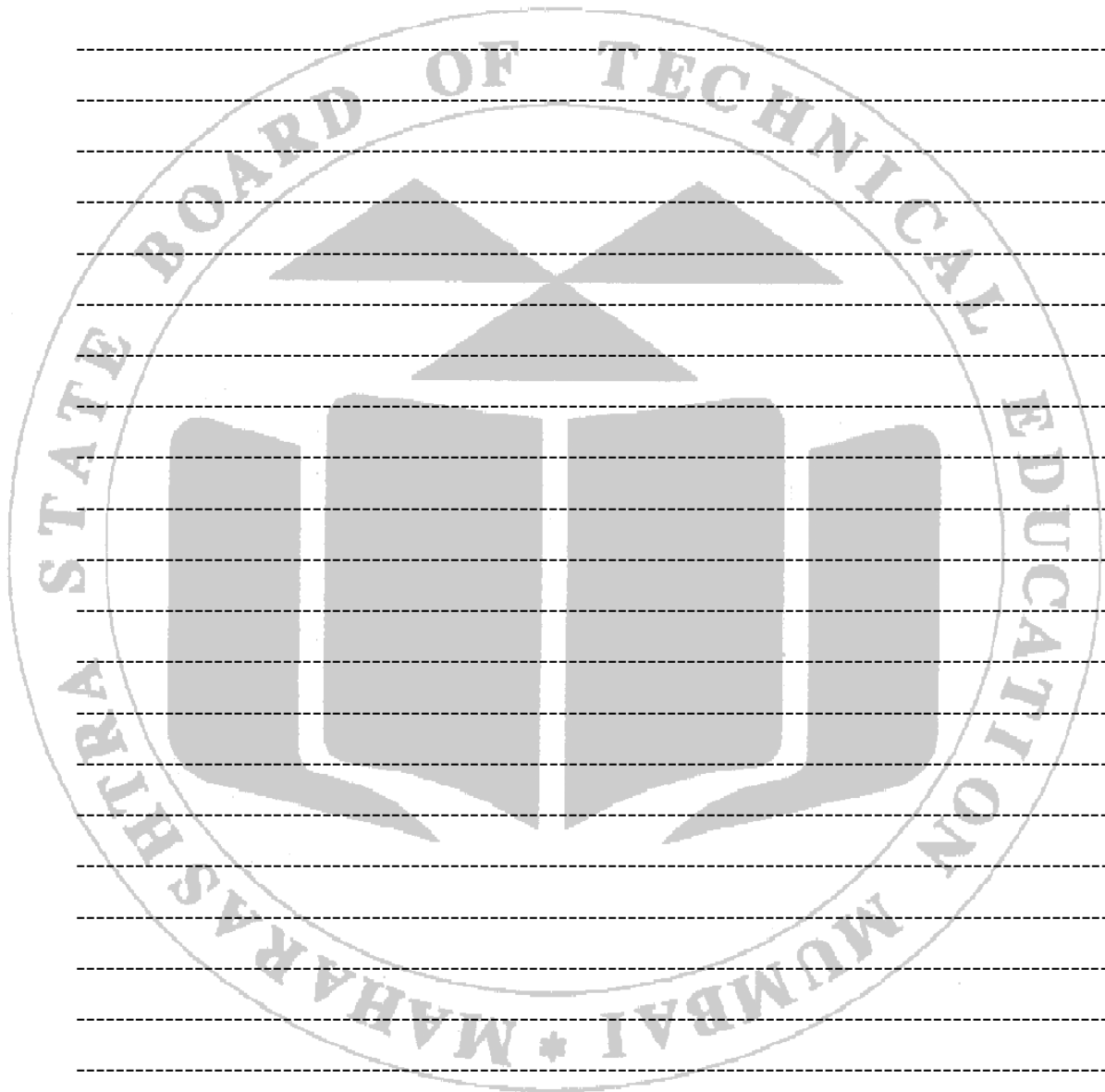

XVI. References / Suggestions for Further Reading

- <https://www.youtube.com/watch?v=fc8zrgYJCJw>
- <https://www.youtube.com/watch?v=UuHofNW40Yw>
- https://www.youtube.com/watch?v=d4_xSRQxDxs
- <https://www.youtube.com/watch?v=zCznMbj2Yn4>

- <https://www.youtube.com/watch?v=ljTEG-B-kGc>

XVII Rubrics for Assessment Scheme

Performance indicators		Weightage
Process related (15 Marks)		60%
1	Preparation of experimental set up	10%
2	Etching the specimen with suitable etchant	25%
3	Observation of the microstructure of the specimen at different magnification using microscope	25%
Product related (10 Marks)		40%
4	Follow Safety measures	10%
5	Answer experiment related questions	10%
6	Submit journal report on time	10%
7	Follow Housekeeping	10%
Total (25Marks)		100%

Marks Obtained			Dated signature of Teacher
Process Related(15)	Product Related(10)	Total (25)	

Practical No. 03: Hardness Testing on Brinell Hardness Tester of given Sample Material.

I. Practical Significance

The hardness tests can provide information from which many important mechanical properties can be derived. Since the hardness test can be conducted easily and quickly, they are very popular in industry. These are used to control processing and for inspection and acceptance of materials and components. The practical significance of the Brinell Hardness Test method lies in its ability to provide critical information about material properties, ensuring quality, reliability, and cost-efficiency in various applications across multiple industries.

II. Industry/Employer Expected Outcome (s)

This practical is expected to develop the following skills for the industry/Employer.

1. State Operation of Hardness Testing Equipment.
2. Applying hardness testing in evaluating components that must withstand high stress and wear, ensuring safety and reliability in critical applications.
3. Developing expertise in testing metals and alloys, understanding their properties, and improving material formulations

III. Course Level Learning Outcome (CO)

CO1 - Select suitable material(s) based on desired properties according to application.

IV. Laboratory Learning Outcome(s)

- Use Brinell Hardness tester
- Determine hardness of given sample.

V. Relative Affective Domain related Outcome(s)-

- Demonstrate working as a leader/a team member.
- Maintain tools and equipment.
- Follow ethical Practices.
- Follow safety practices.
- Practice good housekeeping.

VI. Minimum Theoretical Background with diagram (if required)

The method of hardness testing was introduced by J.A. Brinell in 1900. The Brinell Hardness Test involves pressing a hard spherical indenter into a material under a specified load and measuring the resulting indentation. The Brinell Hardness Number (BHN) is calculated based on the applied load and the indentation diameter. This test is essential for assessing material properties such as strength and wears resistance and is widely used in quality control and material selection processes. In this test, a standard hardened steel ball is indented into the surface of the specimen by a gradually applied load which is maintained on the specimen for a time (usually 10 or 15 sec). Ball of 10 mm, 5 mm, and 2.5 mm are generally used. The diameter of the impression or indentation is measured by microscope and the Brinell hardness number (B.H.N.) is found out by following formula.

Brinell Hardness Number (B.H.N.) = Total load/ surface area of indentation

$$\text{BHN} = \frac{2P}{\pi D(D - \sqrt{D^2 - d^2})}$$

Where:

P is the applied load (in kgf).

D is the diameter of the indenter (in mm).

d is the diameter of the indentation (in mm).

and h = depth of indentation = $(D - \sqrt{D^2 - d^2})/2$

This Brinell Hardness Test is used to determine the hardness number of hard, moderately hard, and soft material E.g. Brass, Bronze, Aluminum, Gold, Copper, etc. Very hard material and brittle material cannot be tested by Brinell hardness tester.

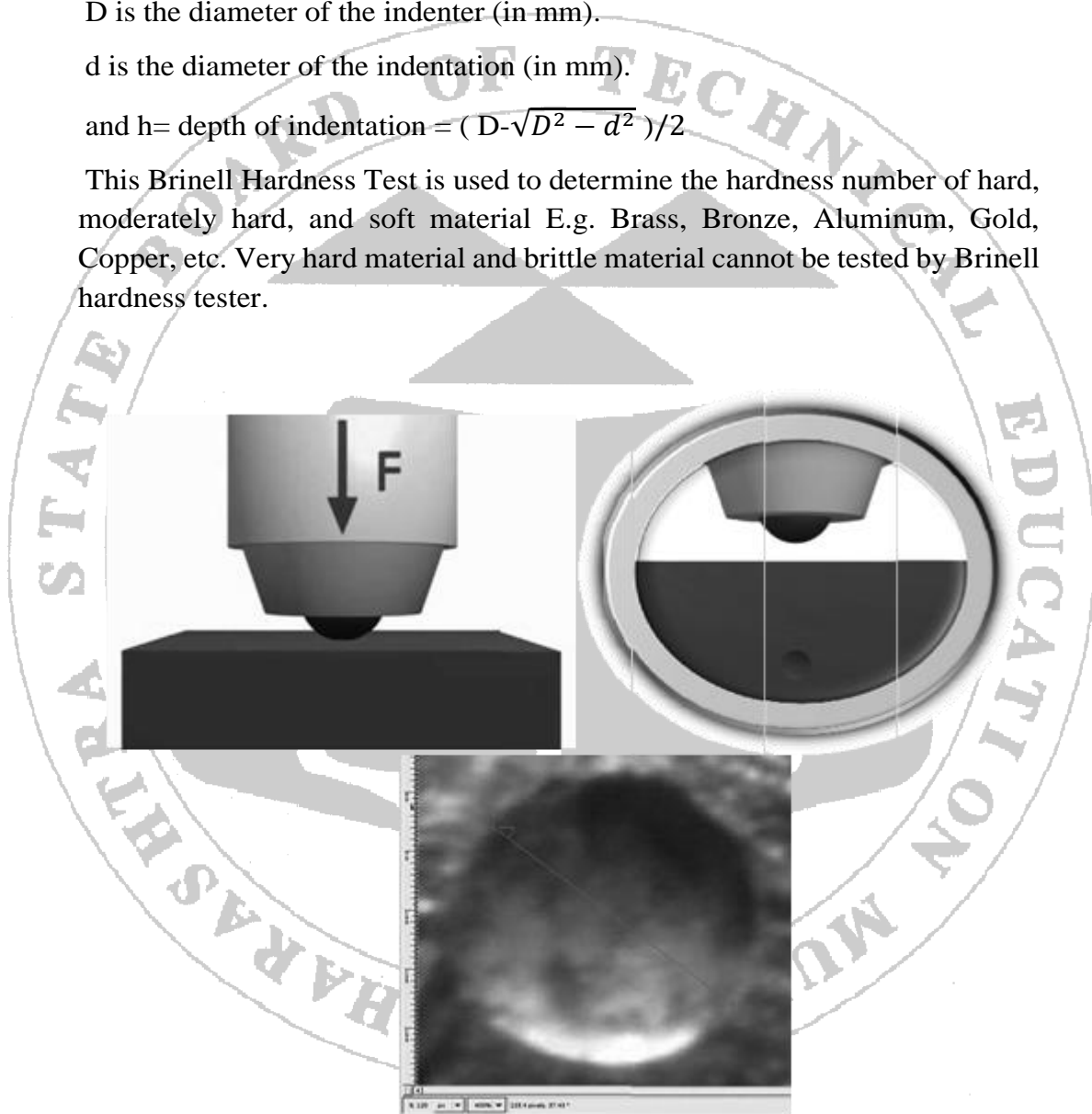

Fig. 3.1 Indentation image

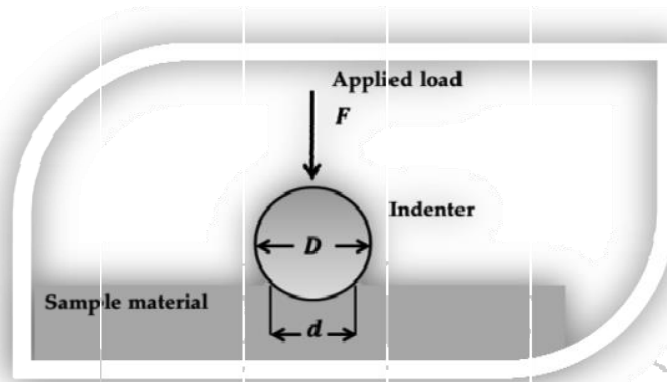

Fig.3.2 Indentation Parameters

VII. Experimental setup (Model)-

SCHEMATIC OF BRINELL HARDNESS TEST

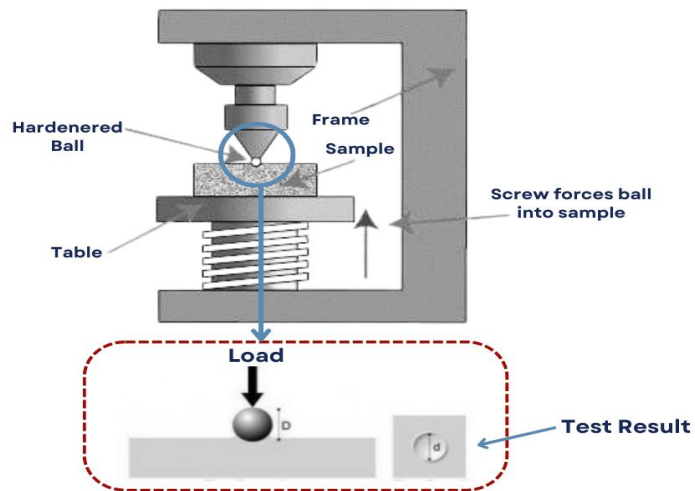

Fig. 3.3 Brinell hardness Tester

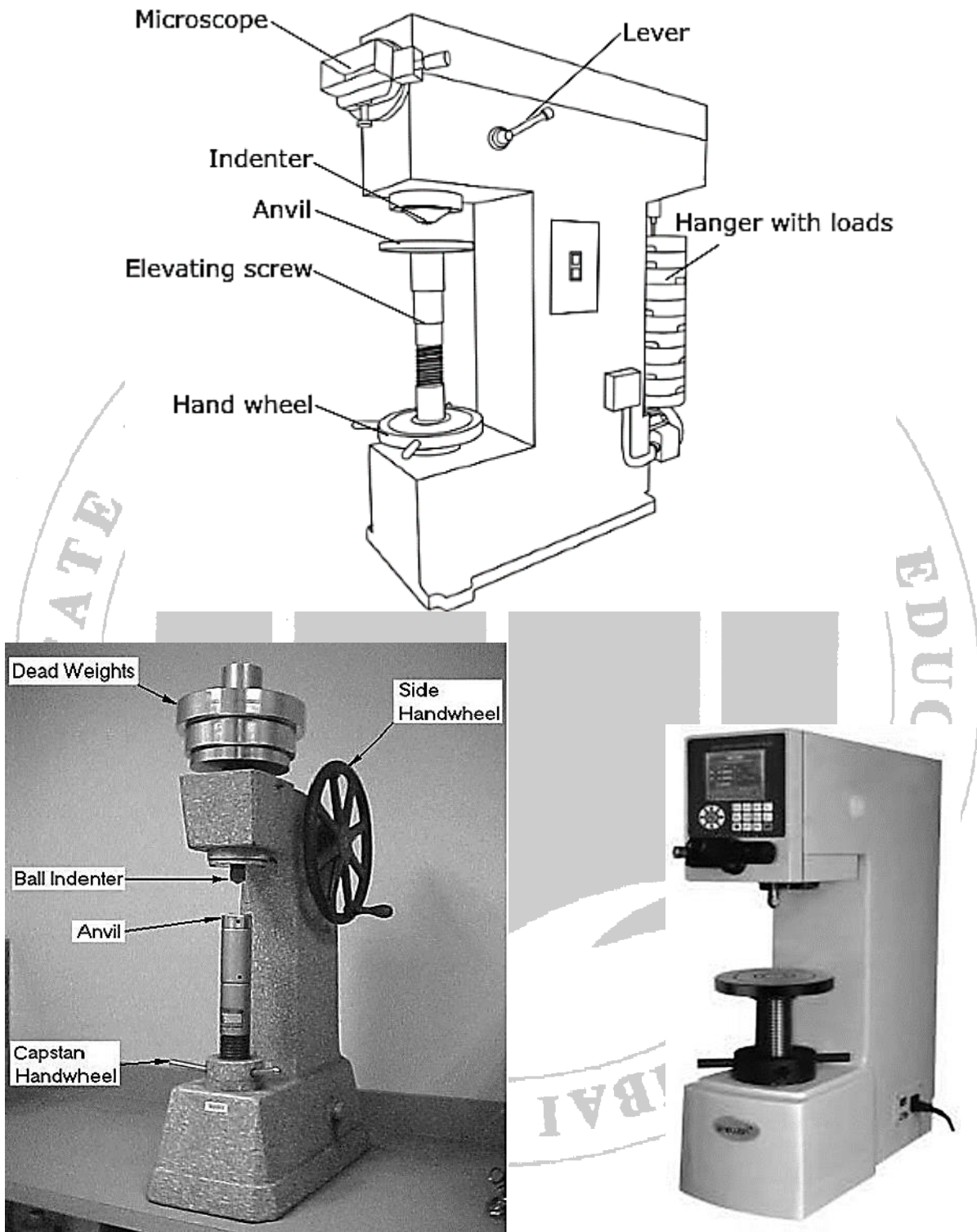

Fig.3.4 Hardness Tester

VIII. Required Resources /Apparatus/Equipment with specification

S. No.	Name of Resource	Suggested Broad Specification	Quantity
1	Digital Brinell hardness Tester	1) Test loads - 500 to 3000 Kgf. in steps of 250 Kg. 2) Magnification of objective - 14 X 3) Maximum test height - 380 mm. 4) Least count -0.001 mm. 5) Throat depth - 200 mm.	2
2	Set of standard specimen	Mild steel, Brass, Bronze, Copper, Aluminium	Each One

IX. Precautions to be Followed

- Ensure the test surface is smooth, clean, and free from scale, rust, or other contaminants that could affect the indentation.
- The sample should be thick enough to prevent deformation on the opposite side. A general rule is that the thickness should be at least 10 times the depth of the indentation.
- The surface should be flat to ensure the indenter contacts uniformly across the test area.
- Use the correct indenter size (usually 2.5 mm, 5 mm, or 10 mm diameter) as specified for the material and the standards being followed
- Apply the appropriate load (e.g., 500 kgf to 3000 kgf) based on the material type and thickness. Incorrect loads can lead to erroneous hardness values.
- Ensure the Brinell hardness tester is properly calibrated before use. Regular calibration checks are necessary to maintain accuracy.
- Apply the load smoothly and avoid jerks or sudden impacts. Maintain the load for the standard dwell time (usually 10 to 30 seconds) as specified by the testing standard.
- Conduct the test in a stable environment. Avoid vibrations or temperature fluctuations that could affect the machine's performance.
- Measure the indentation diameter accurately using a microscope or calibrated optical system. Measure at least two diameters perpendicular to each other and use the average.
- Ensure the indentation is not too close to the edges of the sample or to other indentations, which can affect the accuracy of the measurement. The distance from the edge should be at least 2.5 times the indentation diameter.
- Wear appropriate PPE, such as safety glasses and gloves, to protect against potential hazards.
- Handle the indenter carefully to avoid damaging its surface, as imperfections can affect the test results.

X. Procedure

1. The face of the specimen is lightly grind and rubbed with fine emery paper if required.
2. Ensure the surface of the material is smooth, clean, and free from any scale, rust, or contaminants.
3. Select the proper test table based on the size and shape of the specimen and place it on main screw or elevating screw.
4. Verify that the sample thickness is sufficient to avoid deformation on the opposite side, typically at least 10 times the depth of the intended indentation.
5. Ensure the test surface is flat to ensure uniform contact with the indenter

6. Verify that the Brinell hardness tester is properly calibrated according to the manufacturer's specifications and industry standards
7. Choose the appropriate indenter size (usually 2.5 mm, 5 mm, or 10 mm diameter) based on the material and standard requirements.
8. Select the correct load (e.g., 500 kgf, 1500 kgf, or 3000 kgf) according to the type of material being tested.
9. Check and keep the operating level in horizontal position.
10. Securely place the sample on the anvil or testing platform of the Brinell hardness tester.
11. Align the sample so that the indenter will contact the test surface perpendicularly.
12. Lower the indenter until it makes initial contact with the sample surface.
13. Gradually apply the selected load without causing shock or vibration. Maintain the load for the specified dwell time (usually 10 to 30 seconds) to allow for proper indentation.
14. Carefully remove the load and lift the indenter from the sample, remove the specimen.
15. Use a microscope or calibrated optical system to measure the diameter of the indentation. Measure the diameter in at least two perpendicular directions and record the average diameter.
16. Find the Brinell hardness number using formula.
17. Perform multiple tests (usually at least three) on different areas of the sample to ensure the accuracy and repeatability of the results.
18. Ensure the results are consistent and within the acceptable range of variation.

XI. Observations and calculations -

Room temperature -

S.N.	Test specimen material	Dia. of indenter D mm	Applied load Kgf (F)	Diameter of indentation (d)mm			Average diameter (d)mm	Brinell Hardness Number (BHN)
				1	2	3		
1								
2								
3								
4								
5								

Sample calculations:

Brinell Hardness Number (B.H.N.) = Total load/ surface area of indentation

$$\text{BHN} = \frac{2P}{\pi D(D - \sqrt{D^2 - d^2})}$$

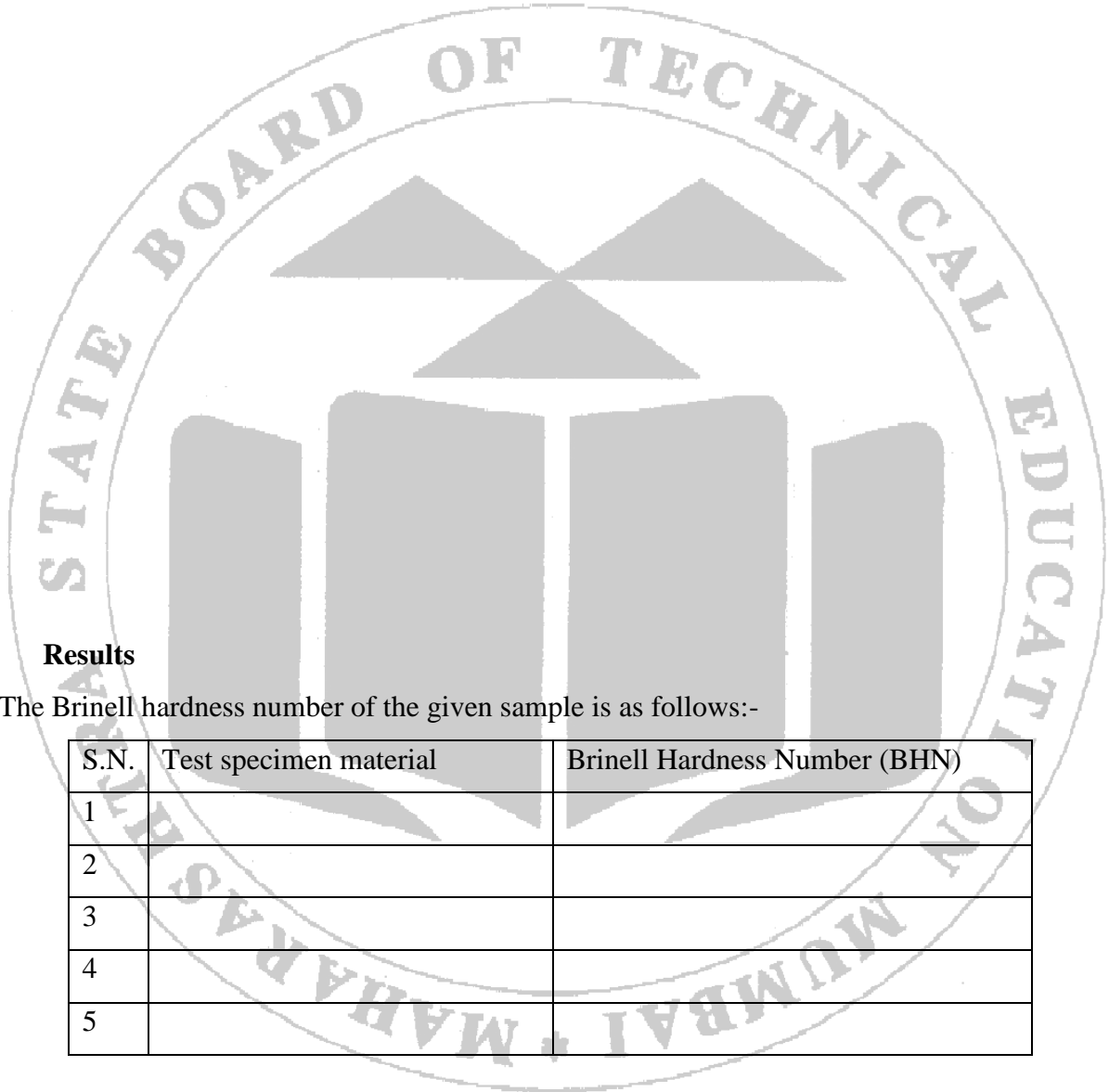

XII. Results

The Brinell hardness number of the given sample is as follows:-

S.N.	Test specimen material	Brinell Hardness Number (BHN)
1		
2		
3		
4		
5		

XIII. Interpretation of Results

XIV. Conclusions and Recommendation

XV. Practical Related Questions

Note: Below given are few sample questions for reference. Teachers must design more such questions so as to ensure the achievement of identified CO.

1. State the difference between Hardness & Hardenability.
2. Explain the surface conditions necessary for Brinell hardness testing.
3. Very hard materials cannot be tested in Brinell hardness testing machine. State the reason
4. List the different types of indenters used in hardness testing.
5. Thickness of the test piece must not be less than 8 times the depth of impression. Justify
6. List the materials which cannot be tested by Brinell hardness tester
7. Can cylindrical samples be tested on Brinell hardness tester.
8. State the reason for using ball indenters of different diameter for Brinell hardness testing
9. Can the sample after testing be used for the desired application. Justify
10. Explain the principle behind the Brinell hardness testing method. How does it measure the hardness of a material.
11. Explain the factors that can affect the accuracy of Brinell hardness test results. How can these factors be controlled or minimized to ensure reliable measurements.
12. In what situations or applications would you choose to use a Brinell hardness tester instead of other hardness testing methods? Provide examples to support your answer.
13. Explain the significance of determining the hardness of a material in engineering applications. Provide examples of situations where knowledge of material hardness is crucial.

[Space for Answer]

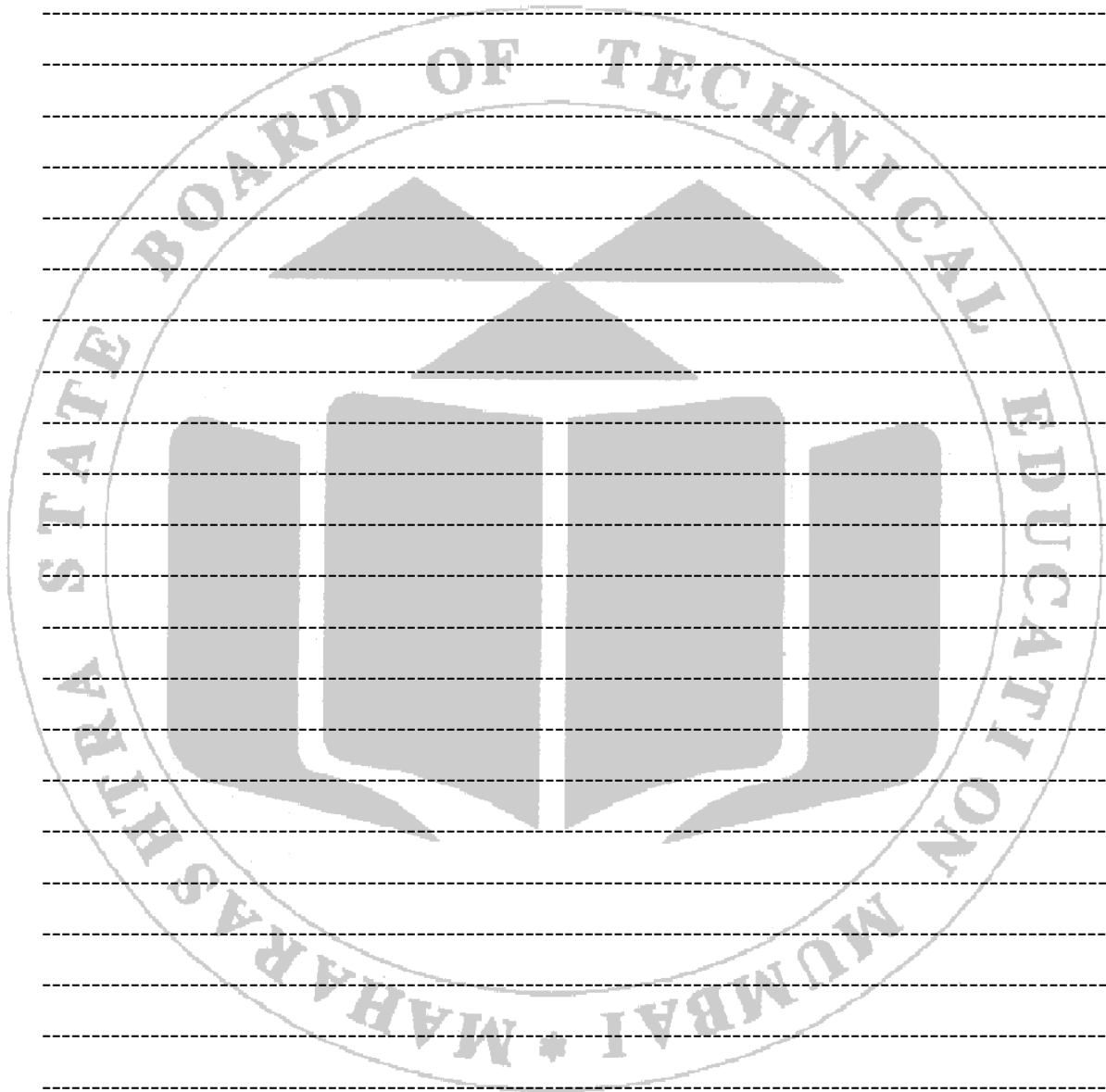

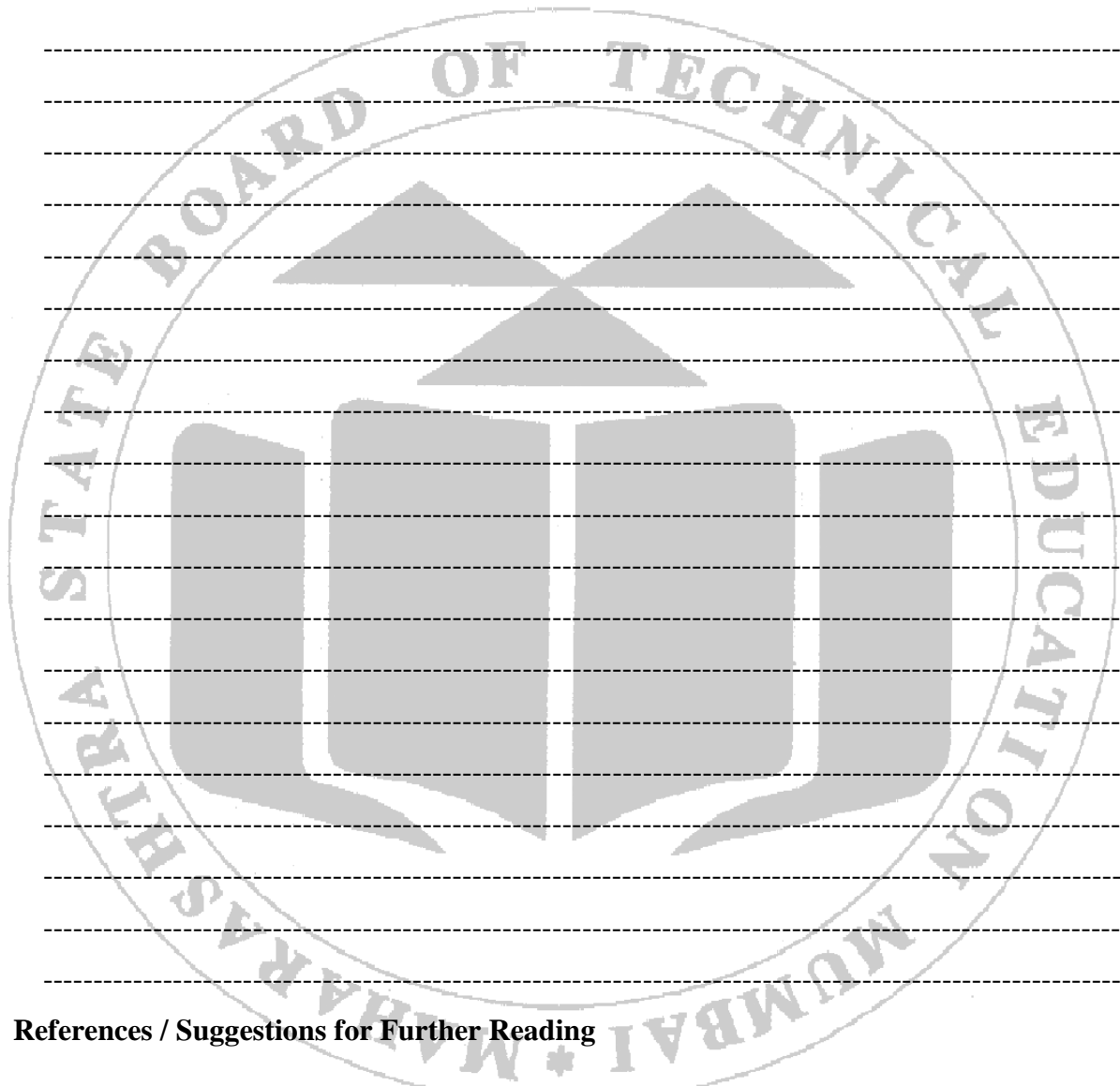

XVI. References / Suggestions for Further Reading

- https://www.youtube.com/results?search_query=brinell+hardness+test
- <https://www.youtube.com/watch?v=WN1nGb37cbw>
- <https://www.youtube.com/watch?v=Mz-o0pqtWoM>
- https://www.youtube.com/watch?v=NQpQ_tj7Gm4

XVII Rubrics for Assessment Scheme

Performance Indicators		Weightage
Process Related (15 Marks)		(60%)
1	Preparation of experimental set up , Selection of indenter and weight	20%
2	Following procedure	15%
3	Measurement of diameter	15%
4	Cleanliness	05%
5	Safety precautions	05%
Product Related (10 Marks)		(40%)
6	Calculation of BHN	10%
7	Interpretation of result	10%
8	Conclusions	10%
9	Practical related questions	10%
Total(25 marks)		100 %

Marks Obtained			Dated signature of Teacher
Process Related(15)	Product Related(10)	Total (25)	

Practical No. 04: Hardness Testing On Rockwell Hardness Tester of given Sample Material.

I. Practical Significance

In the industry, it has become practice to understand hardness as the indentation hardness only, unless otherwise specified. The Rockwell hardness test is probably the most widely used method of hardness testing. It is developed with the depth of penetration as the criterion for the hardness of the metal. This concept was proposed in 1908 by Ludwig at Vienna.

II. Industry/Employer Expected Outcome (s)

This practical is expected to develop the following skills for the industry/Employer

1. Ability to operate the Rockwell hardness tester accurately and efficiently, including setup, calibration, and maintenance.
2. Capability to assess the suitability of materials for specific applications based on hardness test results.

III. Course Level Learning Outcome (CO)

CO1 - Select suitable material(s) based on desired properties according to application.

IV. Laboratory Learning Outcome(s)

- Use a Rockwell Hardness tester.
- Determine hardness of given sample.

V. Relative Affective Domain related Outcome(s)-

- Demonstrate working as a leader/a team member.
- Maintain tools and equipment.
- Follow ethical Practices.
- Follow safety practices.
- Practice good housekeeping.

VI. Minimum Theoretical Background with diagram (if required)

Rockwell hardness test differs from Brinell hardness test in that the hardness is determined from the depth of indentation made by the indenter under a constant load. Various types of indenters may be used in Rockwell hardness tests: diamond indenter and steel-ball indenters of diameter 1/16, 1/8, 1/4, or 1/2 inch. In this test, the indenter is pressed into the specimen surface under an initial minor (light) load followed by a major (heavy) load. The additional depth of indentation made by the indenter under the major load beyond that by the minor load is measured and converted to a hardness number. The hardness number is inversely related to the depth of indentation. In regular Rockwell hardness tests, the minor load is always 10 kg while the major load can be 60, 100, or 150 kgf. A letter is assigned to each scale that employs a particular combination of indenter and major load. A hardness number is suffixed by first the letter H (for hardness), then the letter R (for Rockwell), and finally the letter that indicates the scale used. For example, a value of 45 on the Rockwell C scale is expressed as 45 HRC.

Rockwell hardness tester gives the direct reading of hardness number on a dial provided with the machine. The specimen may be cylinder, cube, thick or thin metallic sheets. Individual can operate the Rockwell hardness tester effectively, interpret the results accurately, and understand the implications of those results in a practical, industrial context.

Table No. 4.1 Rockwell Hardness Tester Machine Scale

Sr. No.	Rockwell Scale	Type of Indenter	Minor load(A) Kg-F	Major load (B) Kg-F	Total load P=(A+B) Kg-F	Application
1	A Scale (HRA)	Diamond Cone	10	60	70	Carbide materials, thin steel, and other hard materials.
2	B Scale (HRB)	1/16 inch Steel Ball	10	100	110	Used for softer metals like copper alloys, soft steels, aluminum alloys, and malleable iron.
3	C Scale (HRC)	Diamond Cone	10	150	160	Used for harder materials such as hardened steel, titanium, and certain ceramics.
4	D Scale (HRD)	Diamond Cone	10	100	110	Used for thin steel and hard cast iron.
5	E Scale (HRE)	1/8 inch Steel Ball	10	100		Used for aluminum and magnesium alloys
6	F Scale (HRF)	1/16 inch Steel Ball	10	60	70	Used for materials like copper and brass alloys
7	G Scale (HRG)	1/16 inch Steel Ball	10	100	110	Used for very soft materials
8	H Scale (HRH)	1/8 inch Steel Ball	10	60	70	Used for aluminum and other soft metals.
9	K Scale (HRK)	1/2 inch Steel Ball	10	150	160	Used for very soft metals and plastics.

VII. Experimental setup (Model)-

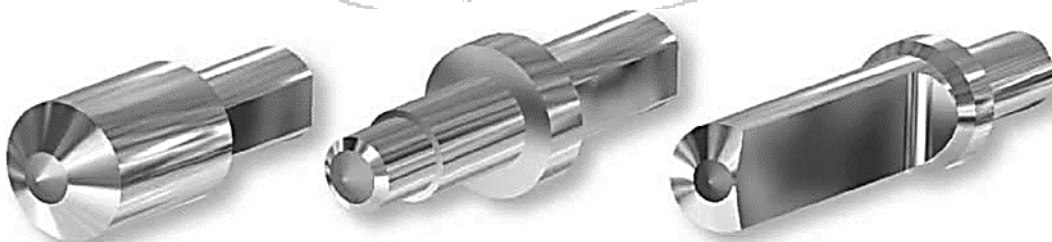
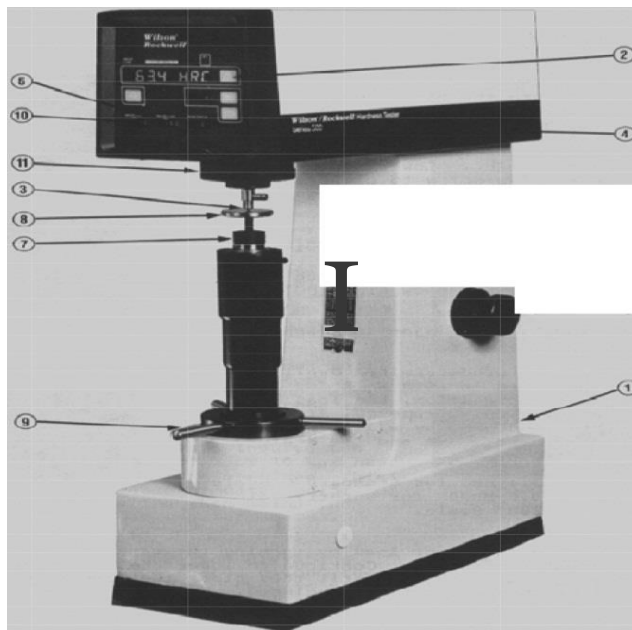

Fig.4.1 Types of Indenter



1. Power switch
2. Test scale scroll key
3. Indenter
4. Indenter display
5. Major load (kg) display
6. Weight selector dial
7. Anvil
8. Specimen
9. Capstan hand wheel
10. Minor load (kg) display

Fig.4.2 Rockwell Hardness Tester

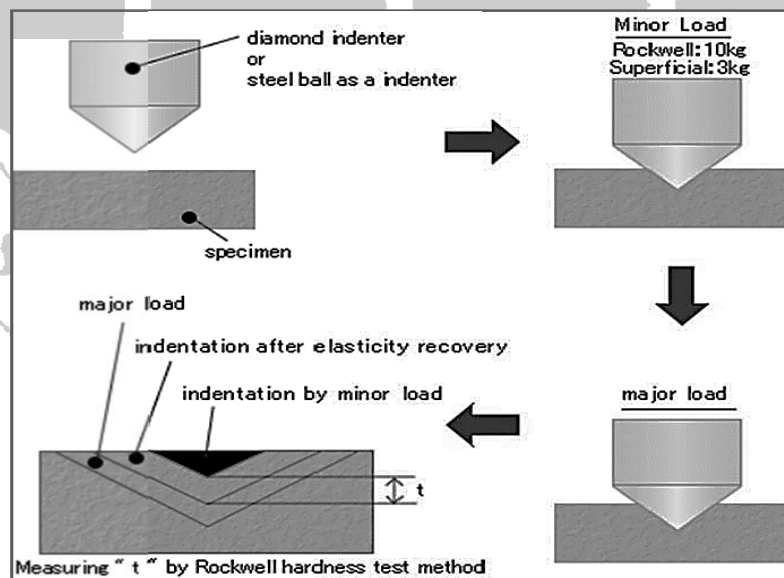

Fig.4.3 Indentation Process

VIII. Required Resources /Apparatus/Equipment with specification

S. No.	Name of Resource	Suggested Broad Specification	Quantity
1	Digital Rockwell hardness Tester	1) Test loads - 60, 100 & 150 kgf 2) Minor load - 10 kg3) Max test height - 230 mm 4) Throat depth - 133 mm along with essential accessories.	02
2	Set of standard specimen	Mild steel, Brass, Bronze, Copper, Aluminium	Each one

IX. Precautions to be Followed

- The surface on which the Rockwell impression is to be made should be flat and sufficiently smooth.
- Ensure the test surface is clean, smooth, and free from any contaminants, rust, or scale.
- Remove any surface irregularities or coatings that might affect the penetration of the indenter.
- The bottom surface also should be free from scale, dirt, or other foreign substances that might crush or flow under the test pressure and so affect the results.
- Use samples that are thick enough to avoid any influence from the anvil or the back of the sample. Generally, the thickness should be at least ten times the depth of the indentation.
- Avoid testing on samples that are too thin or deformable.
- Apply the load slowly and gradually on the sample
- Distance between old impression and location for new impression should be 3D (three times the ball diameter)
- The thickness of the test piece must not be less than 8 times the depth of impression.
- Select the appropriate indenter (diamond or ball) and load based on the material being tested and the desired Rockwell scale.
- Ensure the indenter and load are properly calibrated and suitable for the hardness range of the material.
- Conduct the test in a stable environment to avoid vibrations or temperature fluctuations that could affect the results.
- Ensure the operator is properly trained in the use of the Rockwell hardness tester and understands the importance of each step in the testing process.

X. Procedure

1. Ensure the test surface is clean, smooth, and free from any contaminants, rust, or scale.
2. Verify that the sample is thick enough to avoid any influence from the anvil or the back of the sample.
3. Choose a diamond cone (for hard materials) or a steel ball (for softer materials) based on the material and Rockwell scale.

4. Choose the appropriate test load (measured in kilograms) based on the material and Rockwell scale.
5. Calibrate the machine using standard test blocks to ensure accuracy.
6. Check the indenter and the anvil for any wear or damage.
7. Place the sample on the anvil of the hardness tester.
8. Ensure the sample is properly aligned and stable.
9. Lower the indenter until it makes contact with the sample surface.
10. Apply the preliminary (minor) load (usually 10 kgf) to seat the indenter and establish a reference point.
11. Apply the major load (additional load) smoothly to the indenter. The total load is the sum of the preliminary and major loads.
12. Maintain the load for a specified dwell time to ensure proper indentation.
13. After the dwell time, remove the major load while maintaining the preliminary load.
14. The depth of indentation after the removal of the major load is measured automatically.
15. The Rockwell hardness number is displayed directly on the machine's dial or digital readout.
16. Record the hardness value.
17. For more accurate results, take multiple hardness readings at different locations on the sample.
18. Ensure indentations are sufficiently spaced apart to avoid interaction.
19. Remove the sample and clean the indenter and anvil if necessary.

XI. Observations and Calculations

Room temperature –

S.N.	Material	Thickness	Scale	Type of Indenter	Minor Load	Major Load	Measured Hardness			Average Rockwell Hardness
					kgf	kgf	1	2	3	
1										
2										
3										
4										

Sample calculations:

XII. Results

XIII. Interpretation of Results

XIV. Conclusions and Recommendation

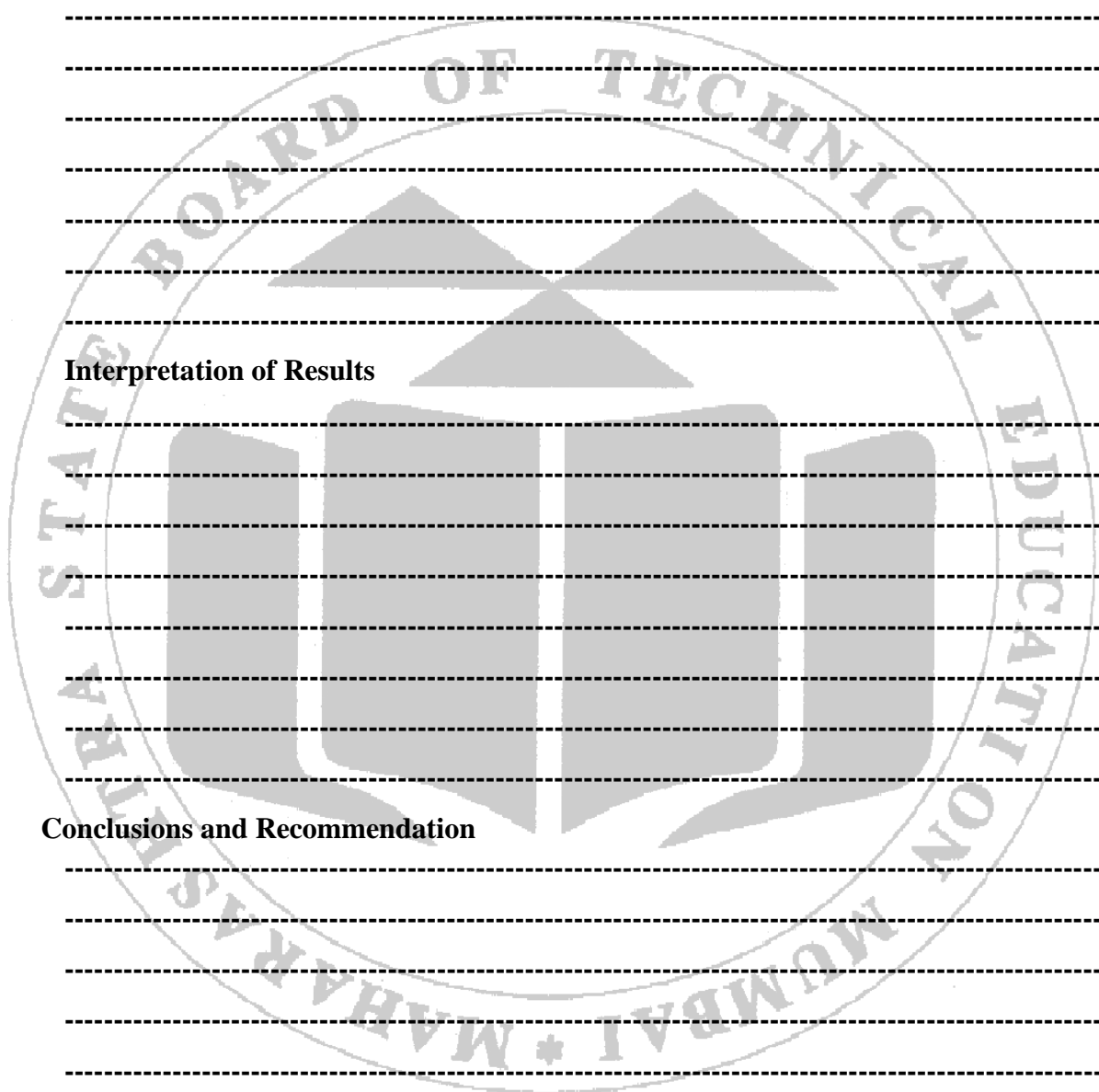

XV. Practical Related Questions

Note: Below given are few sample questions for reference. Teachers must design more such questions so as to ensure the achievement of identified CO.

1. State the purpose of applying the minor load in case of Rockwell Hardness test.
2. State the different types of indenters used in hardness testing.
3. Explain surface condition requirement for Rockwell hardness testing with justification.
4. State the factors which affect the hardness measurement.
5. State the reason for taking at least three readings for hardness testing.
6. State the other methods of hardness measurement.
7. Differentiate other hardness measurement methods with Rockwell method.
8. State the conditions in which hardness measurement by Rockwell method may not be preferred.
9. Can temperature of the surrounding affect hardness of the material.
10. State the course of action to be taken with justification if there is considerable difference between the three readings of hardness of the same sample.
11. Differentiate between the Rockwell and Brinell hardness testing methods. When would you choose one method over the other for determining the hardness of a material.
12. Explain the applications and industries where Rockwell Hardness testing is commonly used. Provide examples of specific materials or components that are evaluated using this testing method.
13. Explain the limitations of Rockwell Hardness testing. In what situations might alternative hardness testing methods be more appropriate.

[Space for Answer]

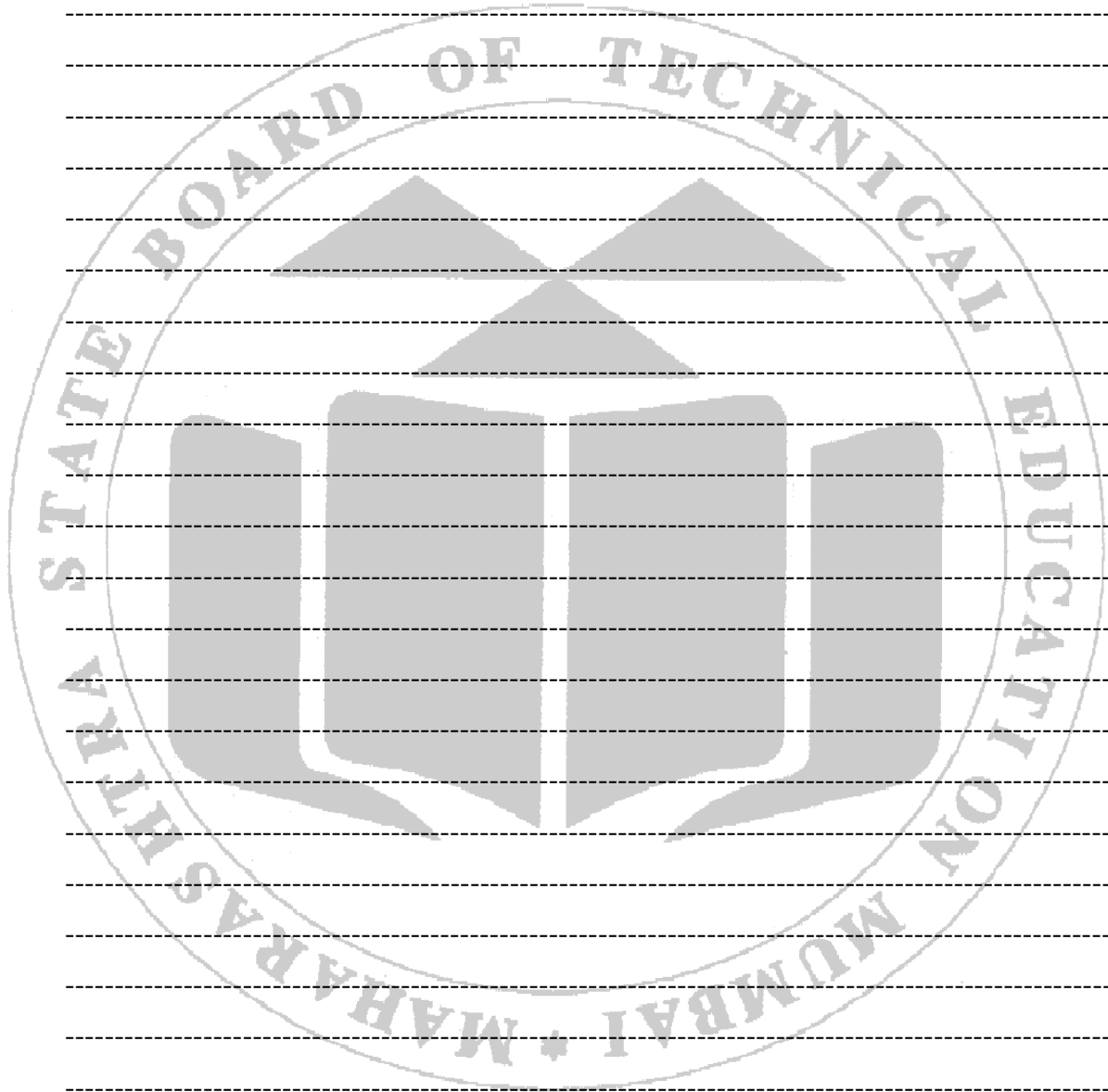

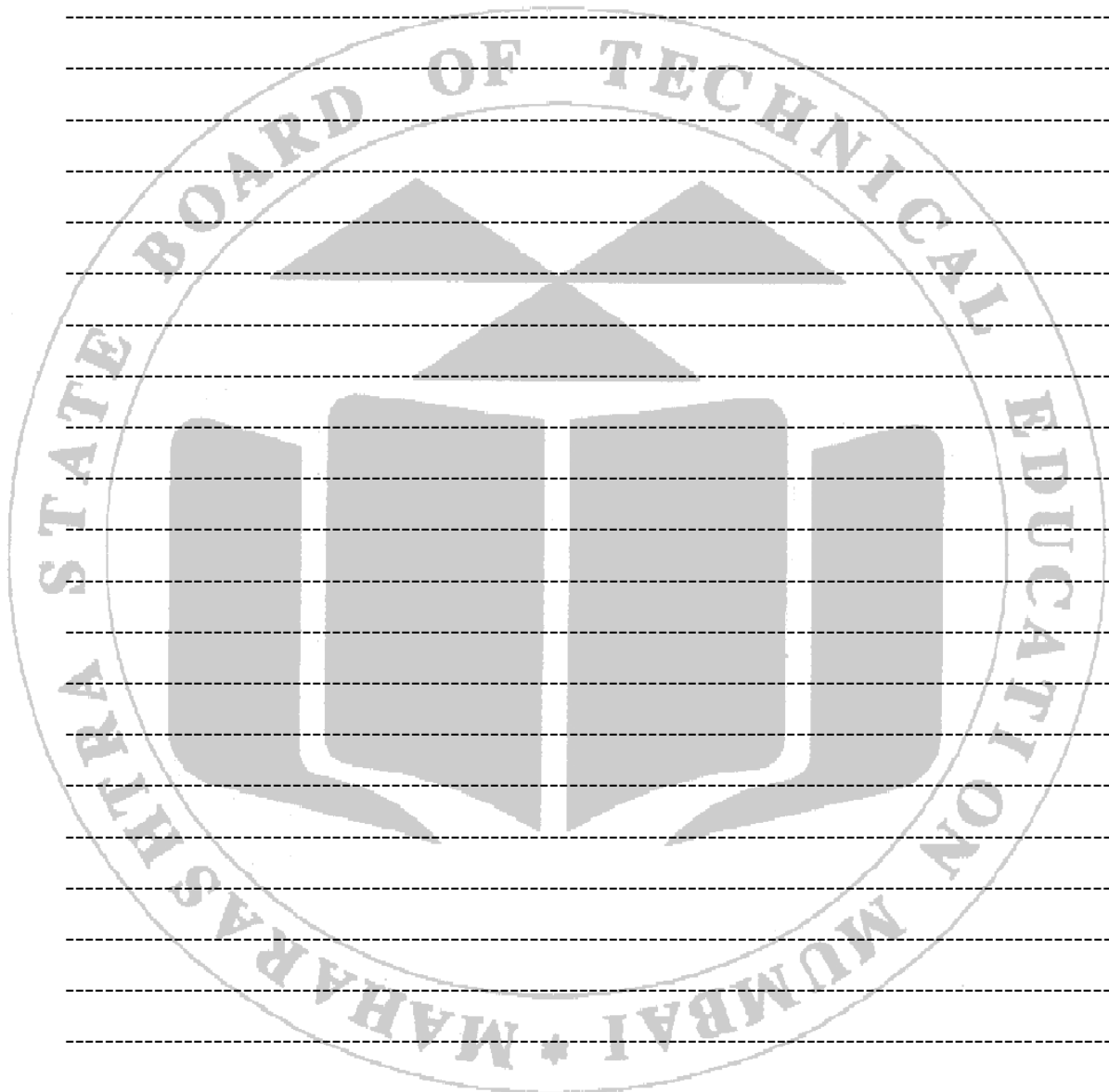

XVI. References / Suggestions for Further Reading

- https://www.youtube.com/results?search_query=rockwell+hardness+test
- https://www.youtube.com/watch?v=z_6nUbHNI3g
- https://www.youtube.com/watch?v=NIWVmp_q_XE
- <https://www.youtube.com/watch?v=G2JGNIIvNC4>

XVII. Rubrics for Assessment Scheme

Performance Indicators		Weightage
Process Related (15 Marks)		(60%)
1	Preparation of experimental set up , Selection of indenter and weight	20%
2	Following procedure	15%
3	Measurement of diameter	15%
4	Cleanliness	05%
5	Safety precautions	05%
Product Related (10 Marks)		(40%)
6	Calculation of RHN	10%
7	Interpretation of result	10%
8	Conclusions	10%
9	Practical related questions	10%
Total(25 marks)		100 %

Marks Obtained			Dated signature of Teacher
Process Related(15)	Product Related(10)	Total (25)	

Practical No. 05: Hardness Testing on Relevant Hardness Testers of Given Untreated and Heat Treated Mild Steels.

I. Practical Significance

Hardness testing provides useful information, which can be correlated to tensile strength, wear resistance, ductility, and other physical characteristics. Hardness testing is therefore useful for monitoring quality control and for the materials selection process. Heat treatment is a process of heating the metal below its melting point and holding it at that temperature for sufficient time and cooling at the desired rate to obtain the required properties. The various heat treatment processes are annealing, normalizing, tempering, hardening, martempering, and austempering. Ensures the hardness of steel components like gears, shafts, and springs meet required specifications for performance and safety. Verifies the hardness of structural steel components, ensuring they can withstand load and environmental conditions. Controls the hardness of tool steels, dies, and molds to ensure long service life and reliability. Hardness testing on untreated and heat-treated mild steels, industries can ensure the reliability, performance, and cost-effectiveness of their steel components and products.

II. Industry/Employer Expected Outcome (s)

This practical is expected to develop the following skills for the industry/Employer.

1. Proficiency in operating various hardness testers, such as Rockwell, Brinell,
2. Understanding various heat treatment processes (e.g., annealing, quenching, tempering) and their impact on material hardness.
3. In-depth knowledge of the properties of mild steel and how heat treatment affects these properties

III. Course Level Learning Outcome (CO)

- CO1 - Select suitable material(s) based on desired properties according to application.

IV. Laboratory Learning Outcome(s)

- Choose appropriate hardness tester for mild steel.
- Use an appropriate hardness tester for mild steel.

V. Relative Affective Domain Related Outcome(s)-

- Demonstrate working as a leader/a team member.
- Maintain tools and equipment.
- Follow ethical Practices.
- Follow safety practices.
- Practice good housekeeping.

VI. Minimum Theoretical Background

Ferrous materials can be heated to above transformation temperature and can be heat treated to obtain different structure. The different heat treatment processes are based on heating the material to certain temperature and employing different cooling rates. In this process, heating temperature and rate of cooling adopted plays an important role.

The different processes are:

1. Annealing
2. Stress-relief annealing.

3. Process annealing.
4. Spheroidising.
5. Full annealing.
6. Normalizing
7. Hardening
8. Tempering

Annealing:

Annealing primarily is the process of heating a metal which is in a metastable or distorted structural state, to a temperature which will remove the instability or distortion and then cooling it to the room temperature so that the structure is stable and/or strain free.

Purpose of Annealing:

1. Removal of residual stress.
2. Refining and homogenizing the structure and to give a coarse pearlite structure.
3. Improving machinability.
4. Improving cold working characteristics for facilitating further cold work.
5. Producing desired microstructure.
6. Removing residual stresses.
7. Improving mechanical, physical, electrical and magnetic properties.
8. Reducing hardness.

Normalizing:

This process involves heating the metal above the transformation temperature up to 900° C and cooling from that temperature adopting the required rate of cooling. This process involves:

- Heating the metal to around 900° C so that the metal transforms completely into austenite.
- Holding at that temperature for some times (3minutes / mm of thickness)
- Cooling at a rate of 80° C to 90° C per hour up to 700°C
- Then air - cooled from 700° C to room temperature.

Purpose of Normalizing:

1. Refining the grain structure and giving a fine pearlite structure.
2. Producing a uniform structure.
3. Achieving the required strength and ductility in a steel that is too soft and ductile for machining.
4. Improving structures in welds.
5. In general, improving engineering properties of steels.

Hardening: (By Quenching)

Hardening is performed on metals to obtain desired hardness and structure. It involves:

- Heating the metal above transformation temperature, around 900°C
- Holding at that temperature for 15 to 30 minutes per 25mm of cross-section.
- Quenching it immediately in a suitable cold medium (brine solution, Water, oil etc.)

Hardness obtained will depend upon the Composition of the material, nature and properties of quenching medium and quenching temperature.

Properties obtained by hardening are:

- Desired hardness can be obtained.
- Strength of material is increased.
- Wear resistance is increased.
- Martensite structure is obtained.

Tempering:

Hardening of metal produces Martensite structure with some retained austenite. The martensite structure makes the metal very hard and brittle. The retained austenite is unstable and it will change with time. This transformation of retained austenite even at room temperature leads to distortion of metal. Due to these factors the hardened metal cannot be used as it is. Hence tempering is carried out on the metals.

Tempering treatment involves:

Heating the metal just above Martensite structure temperature (50° C), holding it at that temperature for some time and then cooling either rapidly or slowly. The purpose of tempering is to remove brittleness and improve ductility in the material.

The Properties obtained after Tempering are:

1. Improvement in ductility and toughness.
2. Slight reduction in hardness.
3. Increase in tensile strength.
4. Reduction in internal stress.

**VII. Experimental set-up
Rockwell Hardness Tester**

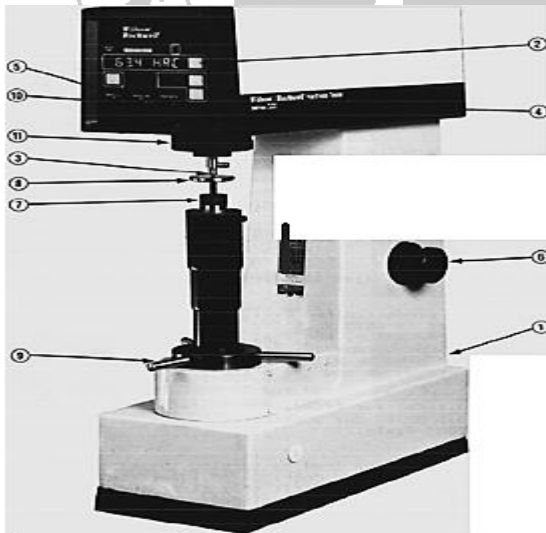

1. Power switch
2. Test scale scroll key
3. Indenter
4. Indenter display
5. Major load (kg) display
6. Weight selector dial
7. Anvil
8. Specimen
9. Capstan hand wheel
10. Minor load (kg) display

Fig.5.1 Rockwell Hardness Tester

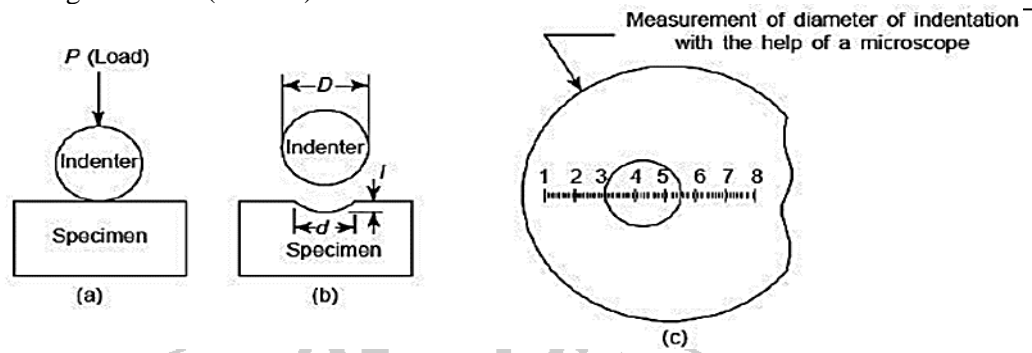

Fig.5.2 (a,b,c) Indentation Process

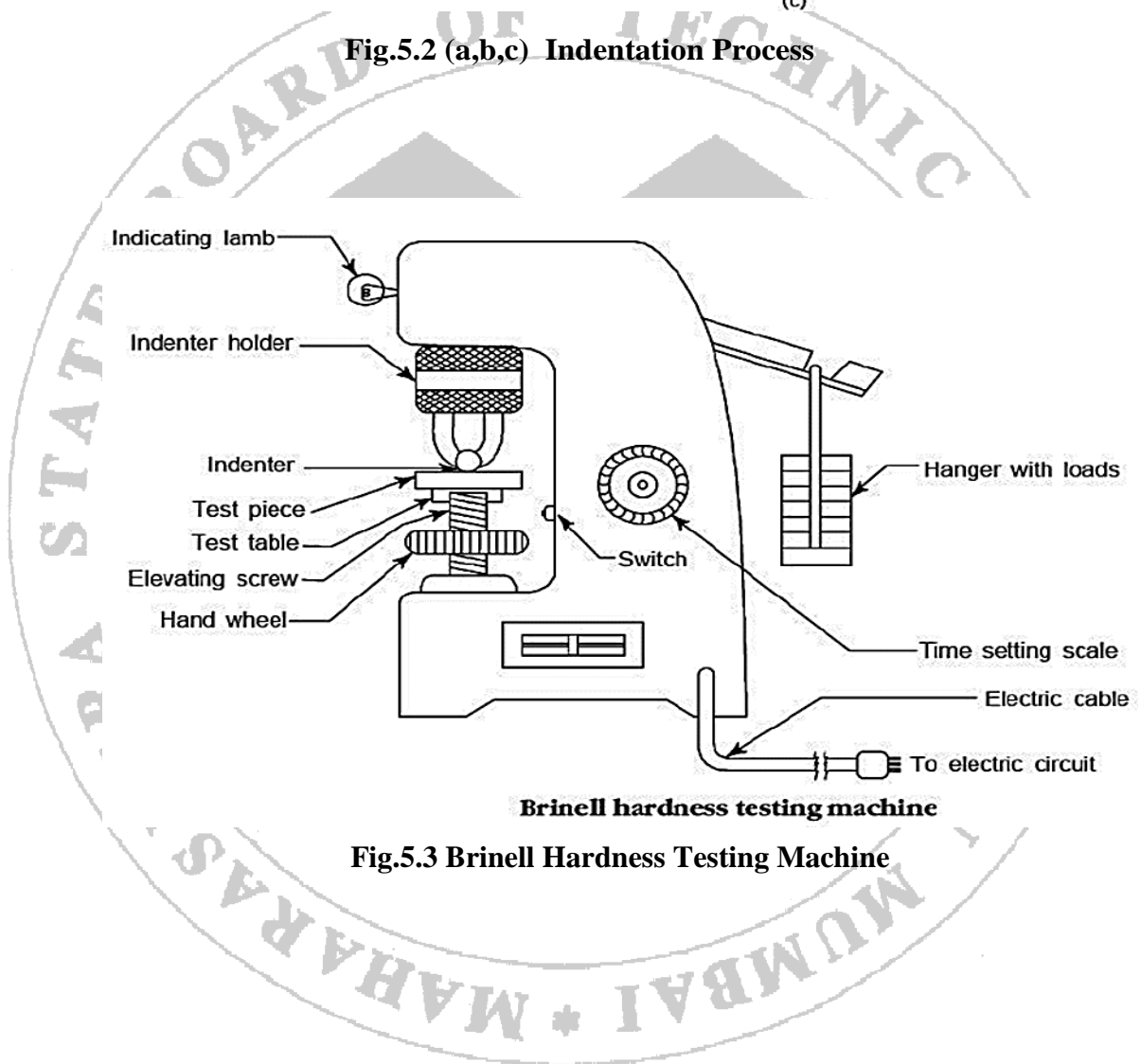

Fig.5.3 Brinell Hardness Testing Machine

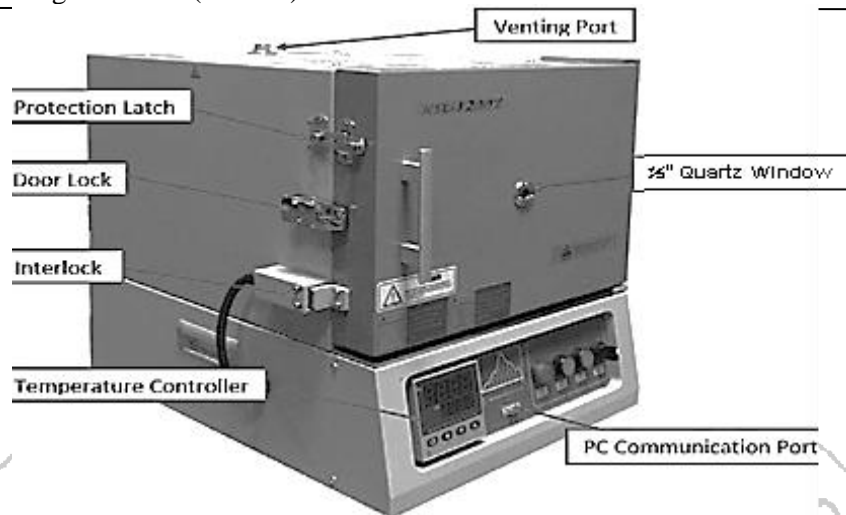

Fig 5.4-Box Type Furnace

VIII. Required Resources /Apparatus/Equipment with specification

S.No.	Name of Resource	Suggested Broad Specification	Quantity
1	Digital Brinell hardness Tester	1) Test loads - 500 to 3000 Kgf. in steps of 250 Kg. 2)Magnification of objective - 14 X 3) Maximum test height - 380 mm. 4) Least count -0.001 mm. 5) Throat depth - 200 mm.	02
2	Digital Rockwell hardness Tester	1) Test loads - 60, 100 & 150 kgf 2) Minor load - 10 kg3) Max test height - 230 mm 4) Throat depth - 133 mm along with essential accessories.	02
3	Laboratory box furnace	Light weight with ceramic fiber wool insulation. Exterior made of G.I. sheets powder coated. Temperature Controlled by Microprocessor based Auto tune PID digital temperature controller with CR/AL Thermocouple. Temperature Range:1100°C., Muffle Size (inside): Temperature Range: 1100°C., Muffle Size (inside):6"x6"x12", Power: 3.5 KW	01
4	Mild steel Specimen(without heat treatment)	Thickness :- Standard	01
5	Mild steel Specimen (with heat treatment)	Thickness :- Standard	01

IX. Precautions to be Followed

Brinell Hardness Tester:

- 1 Ensure the test surface is smooth, clean, and free from scale, rust, or other contaminants that could affect the indentation.
- 2 The sample should be thick enough to prevent deformation on the opposite side. A general rule is that the thickness should be at least 10 times the depth of the indentation.
- 3 The surface should be flat to ensure the indenter contacts uniformly across the test area.
- 4 Use the correct indenter size (usually 2.5 mm, 5 mm, or 10 mm diameter) as specified for the material and the standards being followed
- 5 Apply the appropriate load (e.g., 500 kgf to 3000 kgf) based on the material type and thickness. Incorrect loads can lead to erroneous hardness values.
- 6 Ensure the Brinell hardness tester is properly calibrated before use. Regular calibration checks are necessary to maintain accuracy.
- 7 Apply the load smoothly and avoid jerks or sudden impacts. Maintain the load for the standard dwell time (usually 10 to 30 seconds) as specified by the testing standard.
- 8 Conduct the test in a stable environment. Avoid vibrations or temperature fluctuations that could affect the machine's performance.
- 9 Measure the indentation diameter accurately using a microscope or calibrated optical system. Measure at least two diameters perpendicular to each other and use the average.
- 10 Ensure the indentation is not too close to the edges of the sample or to other indentations, which can affect the accuracy of the measurement. The distance from the edge should be at least 2.5 times the indentation diameter.
- 11 Wear appropriate PPE, such as safety glasses and gloves, to protect against potential hazards.
- 12 Handle the indenter carefully to avoid damaging its surface, as imperfections can affect the test results.

Rockwell Hardness Tester

1. The surface on which the Rockwell impression is to be made should be flat and sufficiently smooth.
2. Ensure the test surface is clean, smooth, and free from any contaminants, rust, or scale.
3. Remove any surface irregularities or coatings that might affect the penetration of the indenter.
4. The bottom surface also should be free from scale, dirt, or other foreign substances that might crush or flow under the test pressure and so affect the results.
5. Use samples that are thick enough to avoid any influence from the anvil or the back of the sample. Generally, the thickness should be at least ten times the depth of the indentation.
6. Avoid testing on samples that are too thin or deformable.
7. Apply the load slowly and gradually on the sample
8. Distance between old impression and location for new impression should be 3D (three times the ball diameter)
9. The thickness of the test piece must not be less than 8 times the depth of impression.
10. Select the appropriate indenter (diamond or ball) and load based on the material being tested and the desired Rockwell scale.
11. Ensure the indenter and load is properly calibrated and suitable for the hardness range of the material.
12. Conduct the test in a stable environment to avoid vibrations or temperature fluctuations that could affect the results.

13. Ensure the operator is properly trained in the use of the Rockwell hardness tester and understands the importance of each step in the testing process.

Laboratory box furnaces

1. Use tongs to insert or remove the specimens from the furnace.
2. Use insulating gloves to open or close the doors to the furnaces.
3. Either cool the specimens immediately after removal from the furnace or place in a designated area for slow cooling. Hot specimens should not be left in the open where they may be accidentally touched.
4. The furnaces should be turned off when not in use.
5. If specimens are left in a furnace and the area is abandoned by the student, a sign must be left with a name and phone number and time for removal.
6. Quenching samples in oil can cause the oil to ignite. Be prepared to cover the container after immersion.
7. Use baskets or tongs for quenching in oil or water.

X. Procedure

Brinell hardness tester

1. The face of the specimen is lightly ground and rubbed with fine emery paper if required.
2. Ensure the surface of the material is smooth, clean, and free from any scale, rust, or contaminants.
3. Select the proper test table based on the size and shape of the specimen and place it on main screw or elevating screw.
4. Verify that the sample thickness is sufficient to avoid deformation on the opposite side, typically at least 10 times the depth of the intended indentation.
5. Ensure the test surface is flat to ensure uniform contact with the indenter.
6. Verify that the Brinell hardness tester is properly calibrated according to the manufacturer's specifications and industry standards.
7. Choose the appropriate indenter size (usually 2.5 mm, 5 mm, or 10 mm diameter) based on the material and standard requirements.
8. Select the correct load (e.g., 500 kgf, 1500 kgf, or 3000 kgf) according to the type of material being tested.
9. Check and keep the operating level in horizontal position.
10. Securely place the sample on the anvil or testing platform of the Brinell hardness tester.
11. Align the sample so that the indenter will contact the test surface perpendicularly.
12. Lower the indenter until it makes initial contact with the sample surface.
13. Gradually apply the selected load without causing shock or vibration. Maintain the load for the specified dwell time (usually 10 to 30 seconds) to allow for proper indentation.
14. Carefully remove the load and lift the indenter from the sample, remove the specimen.
15. Use a microscope or calibrated optical system to measure the diameter of the indentation. Measure the diameter in at least two perpendicular directions and record the average diameter.
16. Find the Brinell hardness number using formula.
17. Perform multiple tests (usually at least three) on different areas of the sample to ensure the accuracy and repeatability of the results.
18. Ensure the results are consistent and within the acceptable range of variation.

Rockwell hardness tester

- Ensure the test surface is clean, smooth, and free from any contaminants, rust, or scale.
- Verify that the sample is thick enough to avoid any influence from the anvil or the back of the sample.

- Choose a diamond cone (for hard materials) or a steel ball (for softer materials) based on the material and Rockwell scale.
- Choose the appropriate test load (measured in kilograms) based on the material and Rockwell scale.
- Calibrate the machine using standard test blocks to ensure accuracy.
- Check the indenter and the anvil for any wear or damage.
- Place the sample on the anvil of the hardness tester.
- Ensure the sample is properly aligned and stable.
- Lower the indenter until it makes contact with the sample surface.
- Apply the preliminary (minor) load (usually 10 kgf) to seat the indenter and establish a reference point.
- Apply the major load (additional load) smoothly to the indenter. The total load is the sum of the preliminary and major loads.
- Maintain the load for a specified dwell time to ensure proper indentation.
- After the dwell time, remove the major load while maintaining the preliminary load.
- The depth of indentation after the removal of the major load is measured automatically.
- The Rockwell hardness number is displayed directly on the machine's dial or digital readout.
- Record the hardness value.
- For more accurate results, take multiple hardness readings at different locations on the sample.
- Ensure indentations are sufficiently spaced apart to avoid interaction.
- Remove the sample and clean the indenter and anvil if necessary.

Heat treatment

1. First, the samples should be checked for hardness.
2. Then, keep them in furnace at 900°C for ½ an hour.
3. Afterwards, one sample is cooled to room temperature in air while other is quench hardened followed by again keeping it in furnace but now at 200-250°C.
4. Then, this sample is also air cooled.
5. As such, one sample is normalized and the other is tempered. Now, the samples are grinded and polished to obtain a flat surface and hardness of both the samples is checked again.

**XI. Observations and calculations –
Brinell Hardness Measurement**

SR No	Specimen	Indenter Diameter (D)	Total Load(P) Kgf	Diameter of Indentation (d) mm			Avg. Diameter d avg.	BHN
				1	2	3		
1	Mild steel Specimen (without heat treatment)							
2	Mild steel Specimen (with heat treatment)							

Rockwell Hardness Measurement

SR No	Specimen	Type of Indenter	Rockwell Hardness Number(RHN)			Avg. RHN
			1	2	3	
1	Mild steel Specimen (without heat treatment)					
2	Mild steel Specimen (with heat treatment)					

Calculations

For Brinell Hardness-

$$BHN = \frac{2P}{\pi D(D - \sqrt{D^2 - d^2})}$$

XII.Results

1. The Rockwell hardness number of mild steel before heat treatment is.....
2. The Rockwell hardness number of mild steel after heat treatment is.....
3. The Brinell hardness number before Heat Treatment.....
4. The Brinell hardness number after Heat Treatment.....

XIII.Interpretation of Results

.....

.....

.....

.....

.....

XIV. Conclusions and Recommendation

XV. Practical Related Questions

Note: Below given are few sample questions for reference. Teachers must design more such questions so as to ensure the achievement of identified CO.

1. State the composition of mild steel.
2. State effect of constituting elements on the properties of mild steel.
3. Draw iron-carbon diagram. Showing important phases.
4. State the effect of heat treatment on the properties of mild steel.
5. State various applications of mild steel.
6. State the limitations of mild steel.
7. Explain various methods to improve properties of mild steel with justification.
8. List five applications with justification where mild steel is not a good choice.

[Space for Answer]

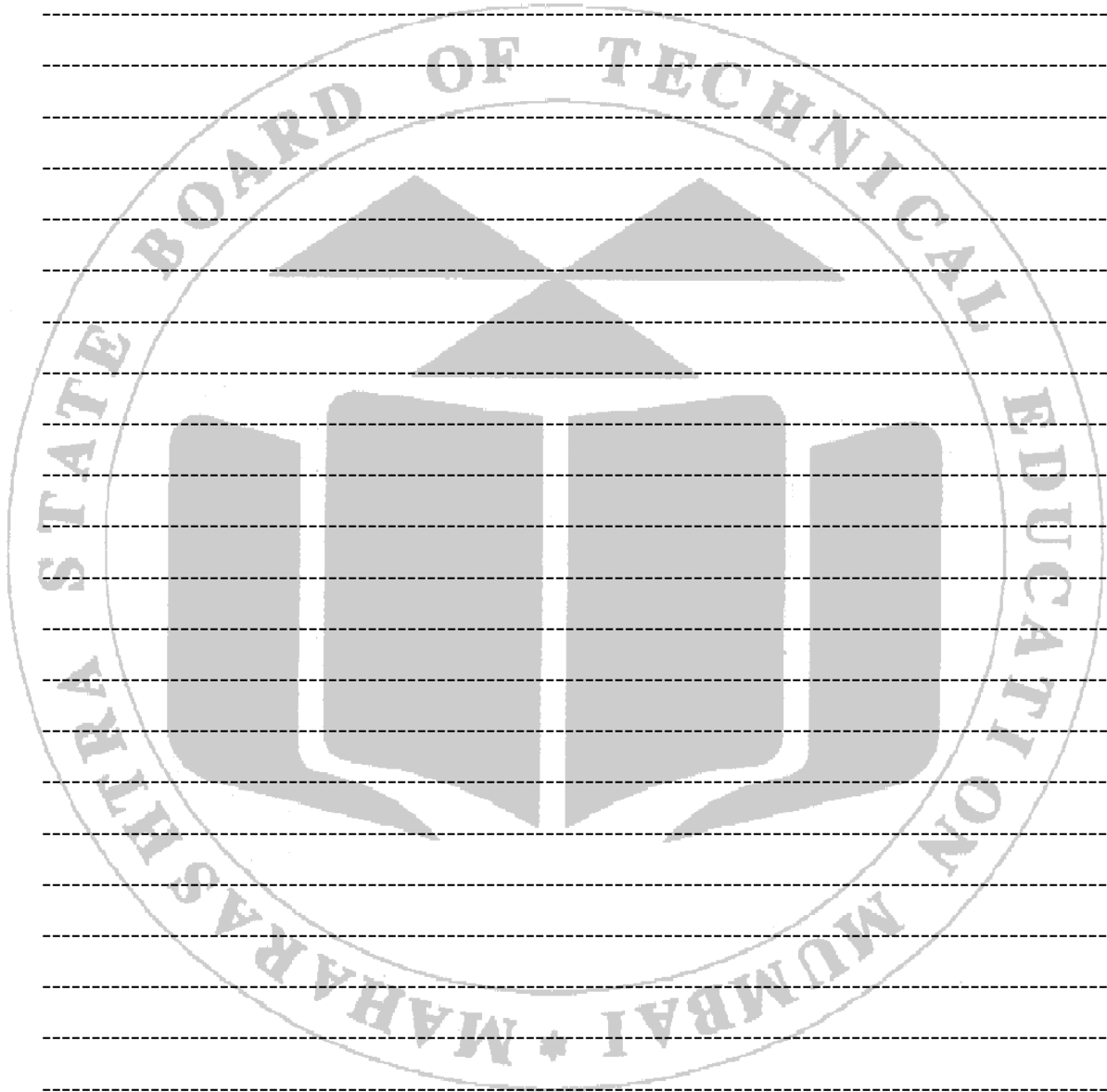

XVI. References / Suggestions for Further Reading

- <https://www.youtube.com/watch?v=yGCnov1m2MY>
- <https://www.youtube.com/watch?v=G2JGNIIvNC4>
- <https://www.youtube.com/watch?v=w8-mAykM00I>
- https://www.youtube.com/watch?v=NIWVmp_q_XE

XVII. Rubrics for Assessment Scheme

Performance Indicators		Weightage
Process Related (15Marks)		60%
1	Preparation of experimental set up	20%
2	Selection of scale, indenter and major weight	15%
3	Following procedure	15%
4	Cleanliness	5%
5	Safety precautions	5%
Product Related (10 Marks)		40%
6	Calculation of hardness	10%
7	Interpretation of result	10%
8	Conclusions	10%
9	Practical related questions	10%
Total (25Marks)		100%

Marks Obtained			Dated signature of Teacher
Process Related(15)	Product Related(10)	Total (25)	

Practical No.6: Hardness Testing on Relevant Hardness Testers of Given Untreated and Heat Treated Alloy Steels.

I. Practical Significance

Hardness testing provides useful information, which can be correlated to tensile strength, wear resistance, ductility, and other physical characteristics. Hardness testing is therefore useful for monitoring quality control and for the materials selection process. Heat treatment is a process of heating the metal below its melting point and holding it at that temperature for sufficient time and cooling at the desired rate to obtain the required properties. The various heat treatment processes are annealing, normalizing, tempering, hardening, martempering, and austempering. Ensures the hardness of steel components like gears, shafts, and springs meet required specifications for performance and safety. Verifies the hardness of structural steel components, ensuring they can withstand load and environmental conditions. Controls the hardness of tool steels, dies, and molds to ensure long service life and reliability. Hardness testing on untreated and heat-treated mild steels, industries can ensure the reliability, performance, and cost-effectiveness of their steel components and products.

II. Industry/Employer Expected Outcome (s)

This practical is expected to develop the following skills for the industry/Employer.

1. Proficiency in operating various hardness testers, such as Rockwell, Brinell,
2. Understanding various heat treatment processes (e.g., annealing, quenching, tempering) and their impact on material hardness.
3. In-depth knowledge of the properties of mild steel and how heat treatment affects these properties

III. Course Level Learning Outcome (CO)

- CO1 - Select suitable material(s) based on desired properties according to application.

IV. Laboratory Learning Outcome(s)

- Choose appropriate hardness tester for mild steel.
- Use an appropriate hardness tester for mild steel.

V. Relative Affective Domain Related Outcome(s)-

- Demonstrate working as a leader/a team member.
- Maintain tools and equipment.
- Follow ethical Practices.
- Follow safety practices.
- Practice good housekeeping.

VI. Minimum Theoretical Background

Ferrous materials can be heated to above transformation temperature and can be heat treated to obtain different structure. The different heat treatment processes are based on heating the material to certain temperature and employing different cooling rates. In this process, heating temperature and rate of cooling adopted plays an important role.

The different processes are:

1. Annealing
2. Stress-relief annealing.
3. Process annealing.
4. Spheroidising.

5. Full annealing.
6. Normalizing
7. Hardening
8. Tempering

Annealing:

Annealing primarily is the process of heating a metal which is in a metastable or distorted structural state, to a temperature which will remove the instability or distortion and then cooling it to the room temperature so that the structure is stable and/or strain free.

Purpose of Annealing:

1. Removal of residual stress.
2. Refining and homogenizing the structure and to give a coarse pearlite structure.
3. Improving machinability.
4. Improving cold working characteristics for facilitating further cold work.
5. Producing desired microstructure.
6. Removing residual stresses.
7. Improving mechanical, physical, electrical and magnetic properties.
8. Reducing hardness.

Normalizing:

This process involves heating the metal above the transformation temperature up to 900° C and cooling from that temperature adopting the required rate of cooling. This process involves:

- Heating the metal to around 900° C so that the metal transforms completely into austenite.
- Holding at that temperature for some times (3minutes / mm of thickness)
- Cooling at a rate of 80° C to 90° C per hour up to 700°C
- Then air - cooled from 700° C to room temperature.

Purpose of Normalizing:

1. Refining the grain structure and giving a fine pearlite structure.
2. Producing a uniform structure.
3. Achieving the required strength and ductility in a steel that is too soft and ductile for machining.
4. Improving structures in welds.
5. In general, improving engineering properties of steels.

Hardening: (By Quenching)

Hardening is performed on metals to obtain desired hardness and structure. It involves:

- Heating the metal above transformation temperature, around 900°C
- Holding at that temperature for 15 to 30 minutes per 25mm of cross-section.
- Quenching it immediately in a suitable cold medium (brine solution, Water, oil etc.)

Hardness obtained will depend upon the Composition of the material, nature and properties of quenching medium and quenching temperature.

Properties obtained by hardening are:

- Desired hardness can be obtained.

- Strength of material is increased.
- Wear resistance is increased.
- Martensite structure is obtained.

Tempering:

Hardening of metal produces Martensite structure with some retained austenite. The martensite structure makes the metal very hard and brittle. The retained austenite is unstable and it will change with time. This transformation of retained austenite even at room temperature leads to distortion of metal. Due to these factors the hardened metal cannot be used as it is. Hence tempering is carried out on the metals.

Tempering treatment involves:

Heating the metal just above Martensite structure temperature (50°C), holding it at that temperature for some time and then cooling either rapidly or slowly. The purpose of tempering is to remove brittleness and improve ductility in the material.

The Properties obtained after Tempering are:

1. Improvement in ductility and toughness.
2. Slight reduction in hardness.
3. Increase in tensile strength.
4. Reduction in internal stress.

VII. Experimental set-up

Rockwell Hardness Tester

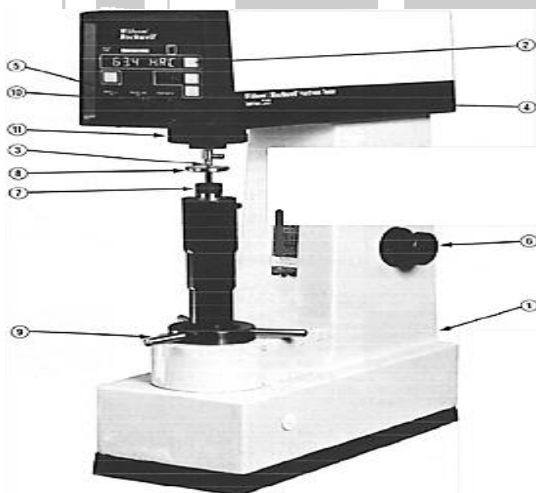

1. Power switch
2. Test scale scroll key
3. Indenter
4. Indenter display
5. Major load (kg) display
6. Weight selector dial
7. Anvil
8. Specimen
9. Capstan hand wheel

Fig.6.1 Rockwell Hardness Tester

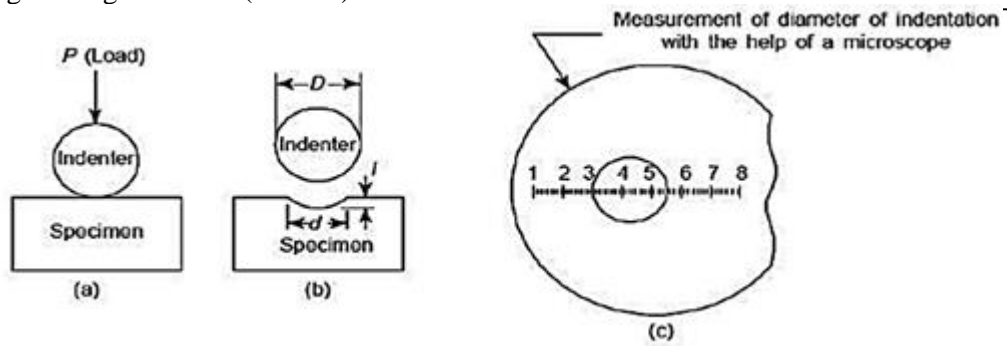

Fig.6.2 (a,b,c) Indentation Process

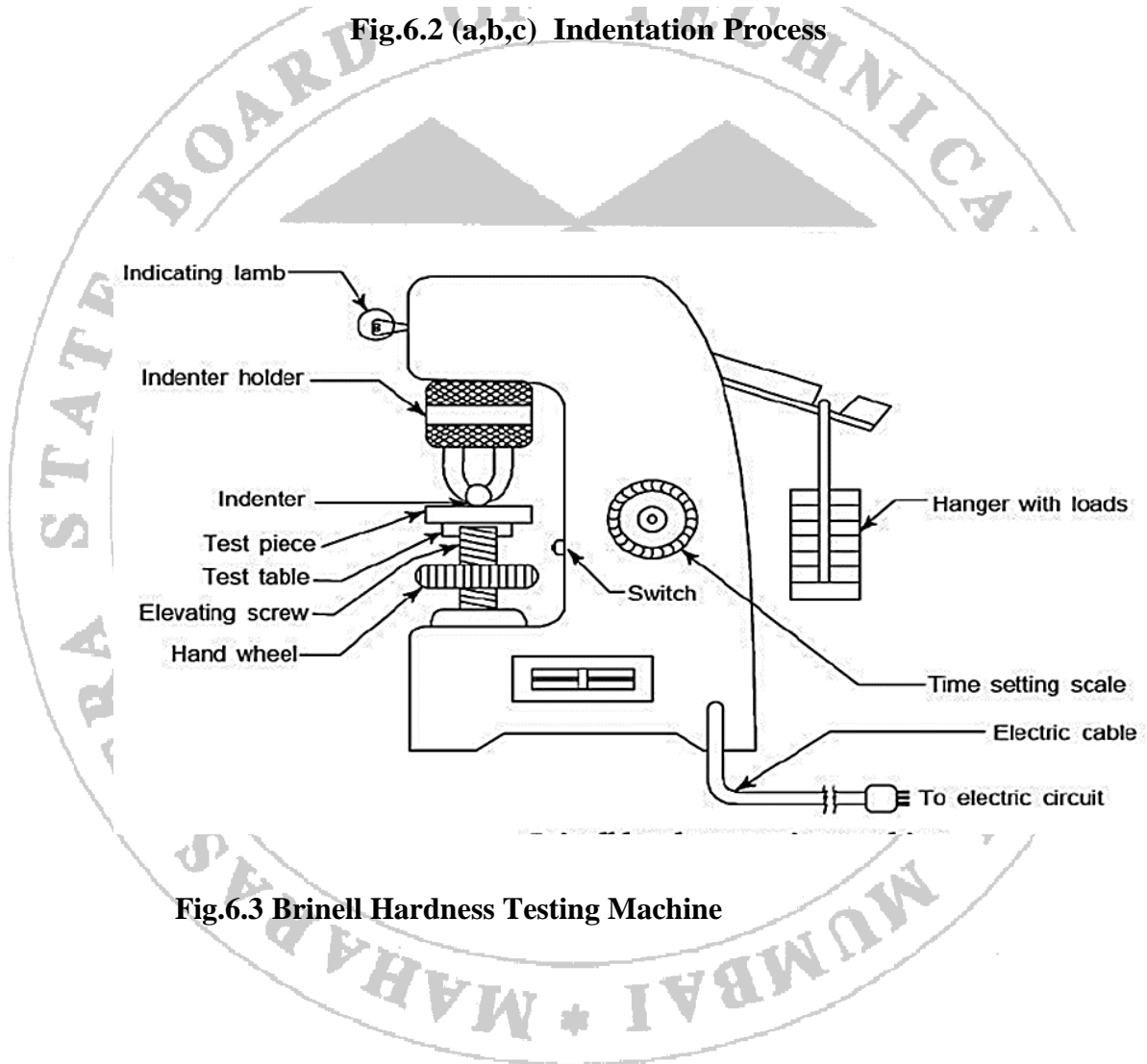

Fig.6.3 Brinell Hardness Testing Machine

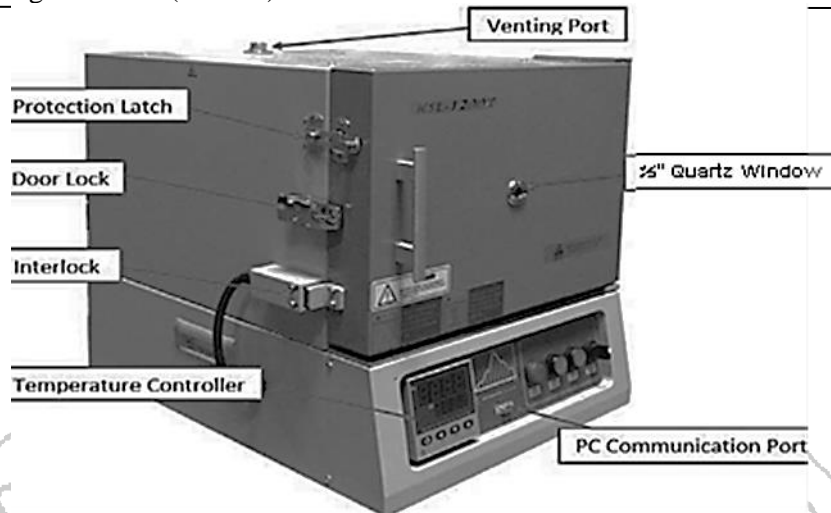

Fig. 6.4 Box furnace

VIII. Required Resources /Apparatus/Equipment with specification

Sr.No.	Name of Resource	Suggested Broad Specification	Quantity
1	Digital Brinell hardness Tester	1) Test loads - 500 to 3000 Kgf. in steps of 250 Kg. 2)Magnification of objective - 14 X 3) Maximum test height - 380 mm. 4) Least count -0.001 mm. 5) Throat depth - 200 mm.	02
2	Digital Rockwell hardness Tester	1) Test loads - 60, 100 & 150 kgf 2) Minor load - 10 kg3) Max test height - 230 mm 4) Throat depth - 133 mm along with essential accessories.	02
3	Laboratory box furnace	Light weight with ceramic fiber wool insulation. Exterior made of G.I. sheets powder coated. Temperature Controlled by Microprocessor based Auto tune PID digital temperature controller with CR/AL Thermocouple. Temperature Range:1100°C., Muffle Size (inside): Temperature Range: 1100°C., Muffle Size (inside):6’’x6’’x12’’, Power: 3.5 KW	01
4	Alloy steel Specimen(without heat treatment)	Thickness :- Standard	01
5	Alloy steel Specimen (with heat treatment)	Thickness :- Standard	01

IX. Precautions to be Followed

Brinell Hardness Tester:

1. Ensure the test surface is smooth, clean, and free from scale, rust, or other contaminants that could affect the indentation.
2. The sample should be thick enough to prevent deformation on the opposite side. A general rule is that the thickness should be at least 10 times the depth of the indentation.
3. The surface should be flat to ensure the indenter contacts uniformly across the test area.
4. Use the correct indenter size (usually 2.5 mm, 5 mm, or 10 mm diameter) as specified for the material and the standards being followed
5. Apply the appropriate load (e.g., 500 kgf to 3000 kgf) based on the material type and thickness. Incorrect loads can lead to erroneous hardness values.
6. Ensure the Brinell hardness tester is properly calibrated before use. Regular calibration checks are necessary to maintain accuracy.
7. Apply the load smoothly and avoid jerks or sudden impacts. Maintain the load for the standard dwell time (usually 10 to 30 seconds) as specified by the testing standard.
8. Conduct the test in a stable environment. Avoid vibrations or temperature fluctuations that could affect the machine's performance.
9. Measure the indentation diameter accurately using a microscope or calibrated optical system. Measure at least two diameters perpendicular to each other and use the average.
10. Ensure the indentation is not too close to the edges of the sample or to other indentations, which can affect the accuracy of the measurement. The distance from the edge should be at least 2.5 times the indentation diameter.
11. Wear appropriate PPE, such as safety glasses and gloves, to protect against potential hazards.
12. Handle the indenter carefully to avoid damaging its surface, as imperfections can affect the test results.

Rockwell Hardness Tester

1. The surface on which the Rockwell impression is to be made should be flat and sufficiently smooth.
2. Ensure the test surface is clean, smooth, and free from any contaminants, rust, or scale.
3. Remove any surface irregularities or coatings that might affect the penetration of the indenter.
4. The bottom surface also should be free from scale, dirt, or other foreign substances that might crush or flow under the test pressure and so affect the results.
5. Use samples that are thick enough to avoid any influence from the anvil or the back of the sample. Generally, the thickness should be at least ten times the depth of the indentation.
6. Avoid testing on samples that are too thin or deformable.
7. Apply the load slowly and gradually on the sample

8. Distance between old impression and location for new impression should be 3D (three times the ball diameter)
9. The thickness of the test piece must not be less than 8 times the depth of impression.
10. Select the appropriate indenter (diamond or ball) and load based on the material being tested and the desired Rockwell scale.
11. Ensure the indenter and load are properly calibrated and suitable for the hardness range of the material.
12. Conduct the test in a stable environment to avoid vibrations or temperature fluctuations that could affect the results.
13. Ensure the operator is properly trained in the use of the Rockwell hardness tester and understands the importance of each step in the testing process.

Laboratory box furnaces

1. Use tongs to insert or remove the specimens from the furnace.
2. Use insulating gloves to open or close the doors to the furnaces.
3. Either cool the specimens immediately after removal from the furnace or place in a designated area for slow cooling. Hot specimens should not be left in the open where they may be accidentally touched.
4. The furnaces should be turned off when not in use.
5. If specimens are left in a furnace and the area is abandoned by the student, a sign must be left with a name and phone number and time for removal.
6. Quenching samples in oil can cause the oil to ignite. Be prepared to cover the container after immersion.
7. Use baskets or tongs for quenching in oil or water.

X. Procedure

Brinell hardness tester

1. The face of the specimen is lightly grind and rubbed with fine emery paper if required.
2. Ensure the surface of the material is smooth, clean, and free from any scale, rust, or contaminants.
3. Select the proper test table based on the size and shape of the specimen and place it on main screw or elevating screw.
4. Verify that the sample thickness is sufficient to avoid deformation on the opposite side, typically at least 10 times the depth of the intended indentation.
5. Ensure the test surface is flat to ensure uniform contact with the indenter
6. Verify that the Brinell hardness tester is properly calibrated according to the manufacturer's specifications and industry standards
7. Choose the appropriate indenter size (usually 2.5 mm, 5 mm, or 10 mm diameter) based on the material and standard requirements.
8. Select the correct load (e.g., 500 kgf, 1500 kgf, or 3000 kgf) according to the type of material being tested.
9. Check and keep the operating level in horizontal position.

10. Securely place the sample on the anvil or testing platform of the Brinell hardness tester.
11. Align the sample so that the indenter will contact the test surface perpendicularly.
12. Lower the indenter until it makes initial contact with the sample surface.
13. Gradually apply the selected load without causing shock or vibration. Maintain the load for the specified dwell time (usually 10 to 30 seconds) to allow for proper indentation.
14. Carefully remove the load and lift the indenter from the sample, remove the specimen.
15. Use a microscope or calibrated optical system to measure the diameter of the indentation. Measure the diameter in at least two perpendicular directions and record the average diameter.
16. Find the Brinell hardness number using formula.
17. Perform multiple tests (usually at least three) on different areas of the sample to ensure the accuracy and repeatability of the results.
18. Ensure the results are consistent and within the acceptable range of variation.

Rockwell hardness tester

- Ensure the test surface is clean, smooth, and free from any contaminants, rust, or scale.
- Verify that the sample is thick enough to avoid any influence from the anvil or the back of the sample.
- Choose a diamond cone (for hard materials) or a steel ball (for softer materials) based on the material and Rockwell scale.
- Choose the appropriate test load (measured in kilograms) based on the material and Rockwell scale.
- Calibrate the machine using standard test blocks to ensure accuracy.
- Check the indenter and the anvil for any wear or damage.
- Place the sample on the anvil of the hardness tester.
- Ensure the sample is properly aligned and stable.
- Lower the indenter until it makes contact with the sample surface.
- Apply the preliminary (minor) load (usually 10 kgf) to seat the indenter and establish a reference point.
- Apply the major load (additional load) smoothly to the indenter. The total load is the sum of the preliminary and major loads.
- Maintain the load for a specified dwell time to ensure proper indentation.
- After the dwell time, remove the major load while maintaining the preliminary load.
- The depth of indentation after the removal of the major load is measured automatically.
- The Rockwell hardness number is displayed directly on the machine's dial or digital readout.
- Record the hardness value.
- For more accurate results, take multiple hardness readings at different locations on the sample.
- Ensure indentations are sufficiently spaced apart to avoid interaction.
- Remove the sample and clean the indenter and anvil if necessary.

Heat treatment

1. First, the samples should be checked for hardness.
2. Then, keep them in furnace at 900°C for ½ an hour.

3. Afterwards, one sample is cooled to room temperature in air while other is quench hardened followed by again keeping it in furnace but now at 200-250°C.
4. Then, this sample is also air cooled.
5. As such, one sample is normalized and the other is tempered. Now, the samples are grinded and polished to obtain a flat surface and hardness of both the samples is checked again.

XI. Observations and calculations

Brinell hardness Measurement

SR No	Specimen	Indenter Diameter (D)	Total Load(P) Kgf	Diameter of Indentation (d) mm			Avg. Diameter d avg.	BHN
				1	2	3		
1	Mild steel Specimen (without heat treatment)							
2	Mild steel Specimen (with heat treatment)							

Rockwell Hardness Measurement

SR No	Specimen	Type of Indenter	Rockwell Hardness Number(RHN)			Avg. RHN
			1	2	3	
1	Mild steel Specimen (without heat treatment)					
2	Mild steel Specimen (with heat treatment)					

Calculations

For Brinell Hardness-

$$BHN = \frac{2P}{\pi D(D - \sqrt{D^2 - d^2})}$$

XII. Results

1. The Rockwell hardness number of mild steel before heat treatment is.....
2. The Rockwell hardness number of mild steel after heat treatment is.....
3. The Brinell Hardness number before Heat Treatment.....
4. The Brinell Hardness number after Heat Treatment.....

XIII. Interpretation of Results

XIV. Conclusions and Recommendation

XV. Practical Related Questions

Note: Below given are few sample questions for reference. Teachers must design more such questions so as to ensure the achievement of identified CO.

1. State the composition of mild steel.
2. State effect of constituting elements on the properties of mild steel.
3. Draw iron-carbon diagram. Showing important phases.
4. State the effect of heat treatment on the properties of mild steel.
5. State various applications of mild steel.
6. State the limitations of mild steel.
7. Explain various methods to improve properties of mild steel with justification.
8. List five applications with justification where mild steel is not a good choice.
9. Explain the limitations of using certain hardness testing methods for assessing the hardness of mild steel, and propose alternative methods to overcome these limitations.

10. State examples of industries or applications where the hardness of mild steel is of particular importance, and discuss the role of hardness testing in ensuring product quality and performance.
11. Explain why hardness testing is important for both untreated and heat-treated mild steels in engineering applications.
12. Explain why Brinell hardness testing may be preferred for evaluating the hardness of heat-treated mild steel compared to other hardness testing methods.

[Space for Answer]

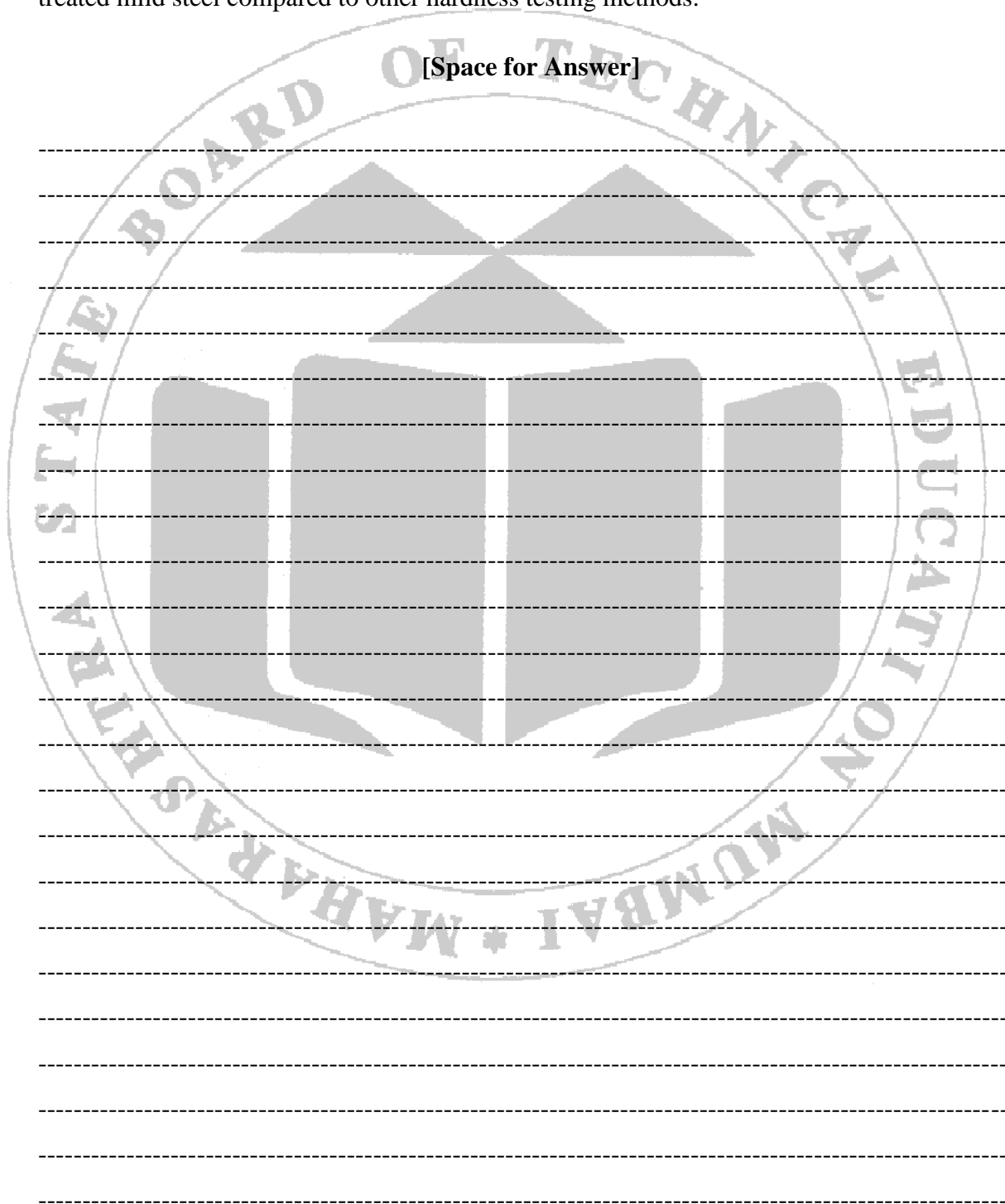

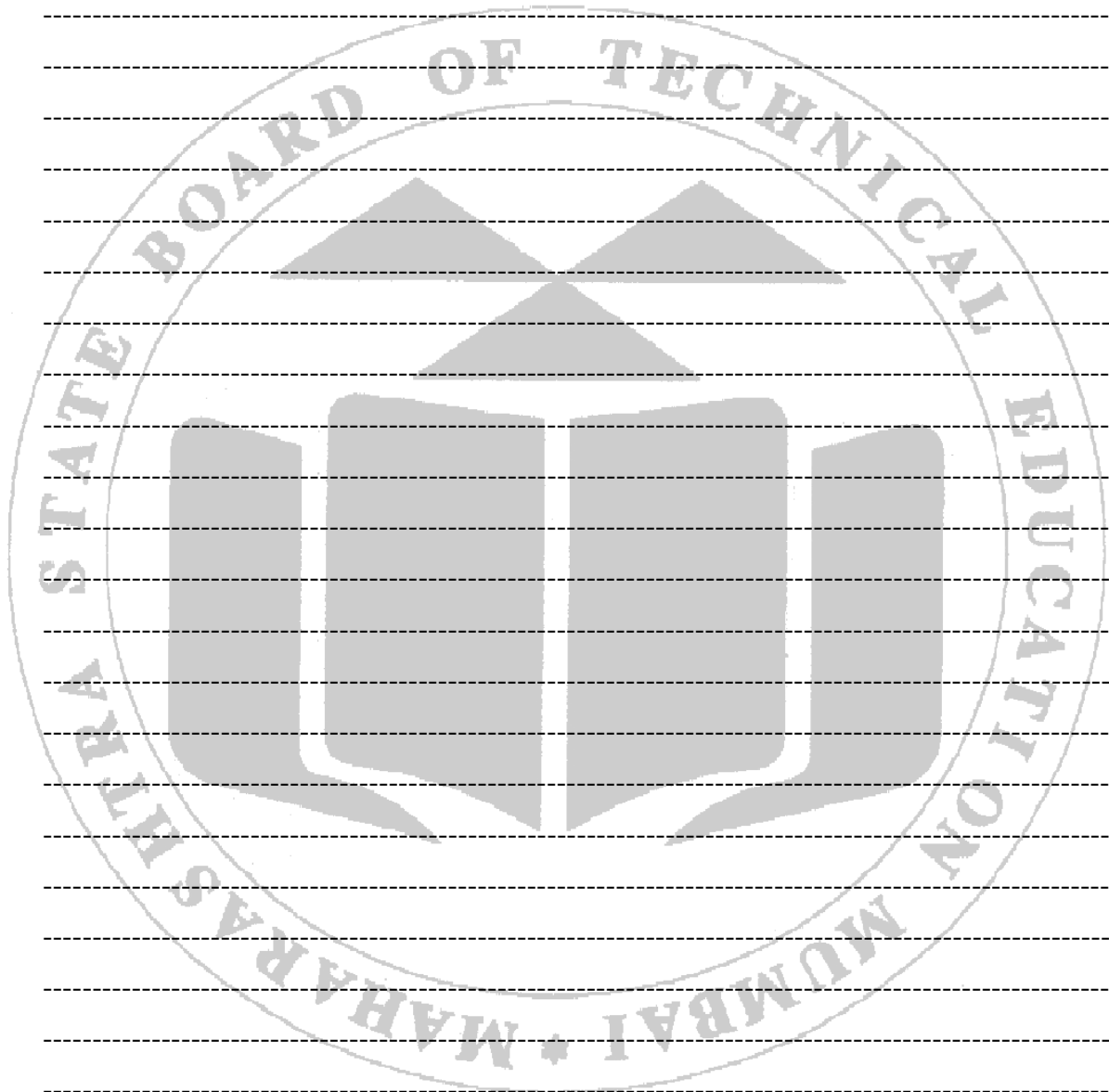

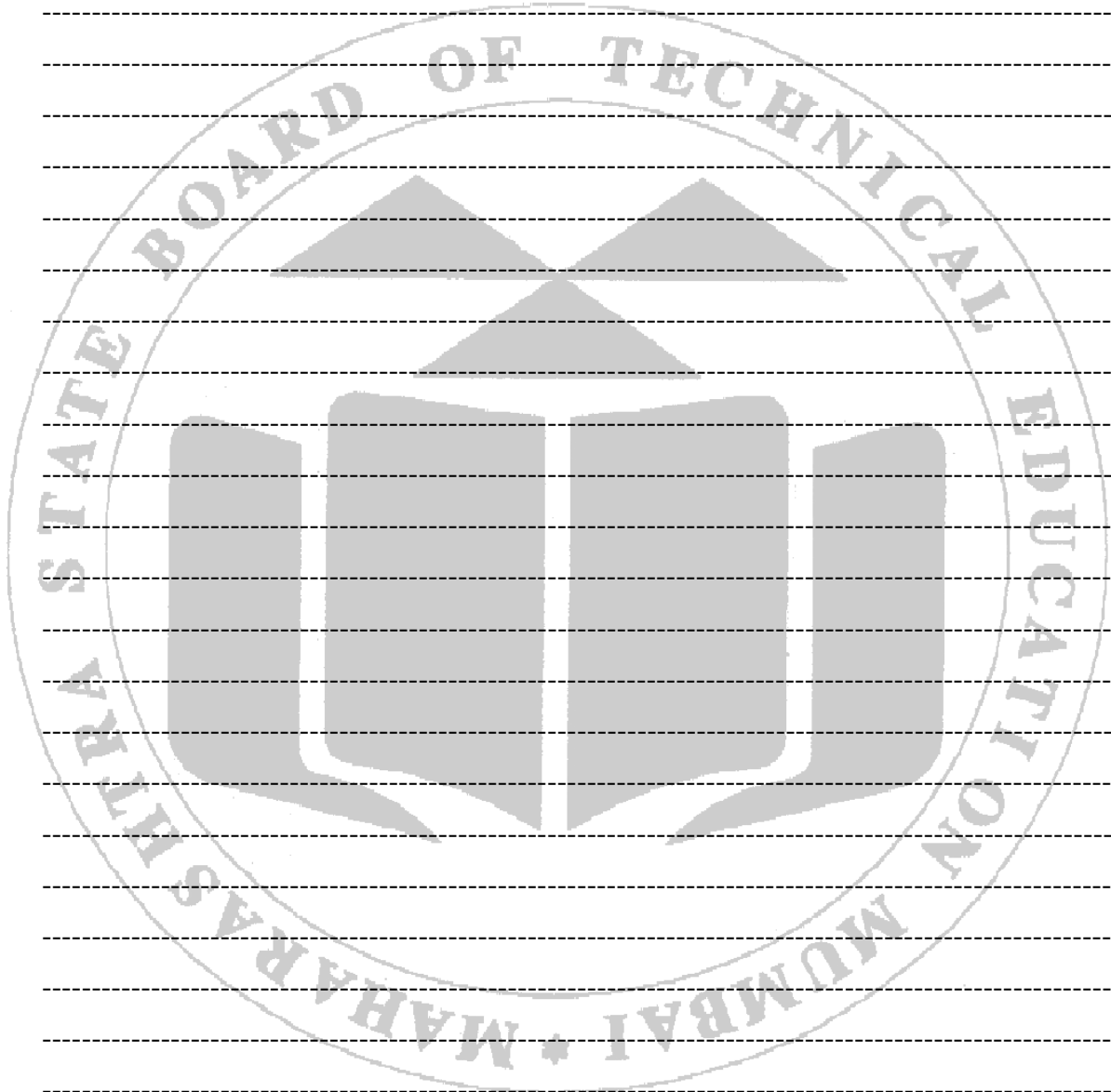

XVI. References / Suggestions for Further Reading

- https://youtu.be/_yonqoGymzE?t=381
- https://youtu.be/kLbbR_cpBnk?t=48
- <https://youtu.be/J8r6wRvskxU?t=14>

XVII. Rubrics for Assessment Scheme

Performance Indicators		Weightage
Process Related (15Marks)		60%
1	Preparation of experimental set up	20%
2	Selection of scale, indenter and major weight	15%
3	Following procedure	15%
4	Cleanliness	5%
5	Safety precautions	5%
Product Related (10Marks)		40%
6	Calculation of hardness	10%
7	Interpretation of result	10%
8	Conclusions	10%
9	Practical related questions	10%
Total (25Marks)		100%

Marks Obtained			Dated signature of Teacher
Process Related(15)	Product Related(10)	Total (25)	

Practical No. 07: Microstructure of Cast Iron Using Metallurgical microscope on Standard Specimens.

I. Practical Significance

Metallographic analysis is a valuable tool. By properly documenting the initial specimen condition and the further microstructural analysis, metallography provides a powerful quality control as well as an invaluable investigative tool. Metallurgical analysis (metallography) of the microstructure provides the Material Scientist or Metallurgist information about phase structure, grain size, solidification structure, casting voids, etc. Optical microscopy is sufficient for general purpose examination. For advanced examination research laboratories often use electron microscopes (SEM and TEM), x-ray and electron diffractometers or possibly other scanning devices. The effects of most industrial processes applied to metals to control their properties can be explained by studying their microstructures. In summary, the practical significance of microstructural analysis of cast iron using a metallurgical microscope is profound, influencing quality control, failure analysis, research and development, performance evaluation, industrial applications, cost efficiency, environmental sustainability, and regulatory compliance. This comprehensive understanding is crucial for optimizing the performance and reliability of cast iron components in various industries.

II. Industry/Employer Expected Outcome (s)

This practical is expected to develop the following skills for the industry/Employer

1. Ability to prepare metallographic samples, including sectioning, mounting, grinding, polishing, and etching.
2. Understanding the relationship between microstructure and the mechanical properties of cast iron.
3. Using microstructural analysis to diagnose manufacturing issues or failures in cast iron components

III. Course Level Learning Outcome (CO)

- CO1 - Select suitable material(s) based on desired properties according to application.
- CO2 - Choose relevant alloy steel & Cast iron for mechanical components.

IV. Laboratory Learning Outcome(s)

- Use a metallurgical microscope.
- Interpret the microstructure of Cast Iron.

V. Relative Affective Domain related Outcome(s)-

- Demonstrate working as a leader/a team member.
- Maintain tools and equipment.
- Follow ethical Practices.
- Follow safety practices.
- Practice good housekeeping.

VI. Minimum Theoretical Background

Cast iron is an alloy of iron and carbon where the carbon content lies in a range between 2.1 and 6.67 wt%. Cast iron is of following types

1. Grey cast iron- Characterized by graphite flakes
2. Nodular (ductile) cast iron- Contains spherical graphite nodules.
3. White cast iron- Contains cementite, leading to a hard and brittle structure.
4. Malleable cast iron- Heat-treated white cast iron with temper carbon in the form of irregular nodules.

Proper preparation of metallographic specimens requires that a rigid step-by-step process be followed. In sequence, the steps include sectioning, mounting, coarse grinding, fine grinding, polishing, etching and microscopic examination.

Sectioning is cutting the small piece of specimen from metal for examination.

Grinding is an abrasive machining process that uses a grinding wheel as the cutting tool.

Polishing is the process of creating a smooth and shiny surface by rubbing it or using a chemical action, leaving a surface with a significant specular reflection.

Etchant	Composition	Application	Conditions
Pical (Picric acid + Alcohol)	45 ml Glycerol 15 ml Nitric acid 30 ml Hydrochloric acid	White and malleable cast iron, grey cast iron	15 to 30 seconds.
Nital (Nitric acid + Alcohol)	Nitric acid (conc.) (sp. gr. 1.42) 2 to 5 ml. Ethyl or methyl alcohol (absolute) 100ml.	White and malleable cast iron	15 to 30 seconds.
Alkaline Sodium Picrate	Picric acid 2 gm. Sodium hydroxide 25 gms. Water (distilled) 100 ml.	Steels and cast iron	10 minutes.

Bright Field (B.F.) illumination is the most common illumination technique for metallographic analysis. The light path for B.F. illumination is from the source, through the objective, reflected off the surface and returning through the objective and back to the eyepiece or camera. This type of illumination produces a bright background for flat surfaces with the non-flat features (pores, edges, etched grain boundaries) being darker as light is reflected back at an angle.

Understanding the role of microstructure in the performance of cast iron components in various industries (e.g., automotive, construction). professionals can effectively conduct microstructural analysis of cast iron and apply their findings to improve material performance and solve practical engineering problems.

VII. Experimental set-up

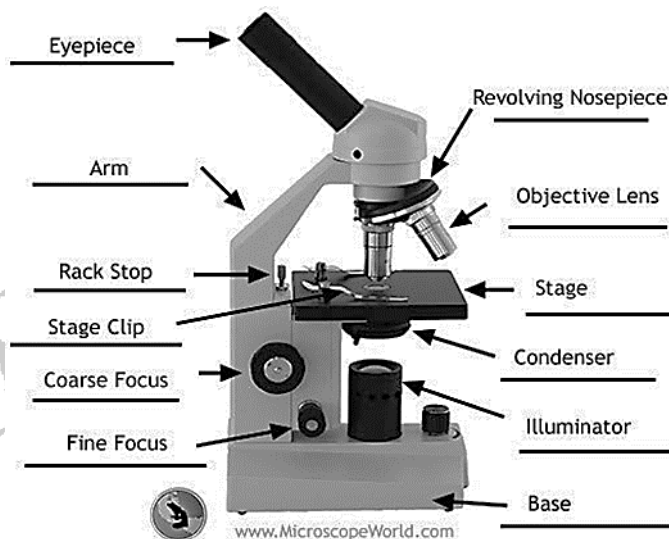

Fig.7.1 Metallurgical Microscope

VII. Required Resources /Apparatus/Equipment with specification.

S.N.	Name of Resource	Suggested Broad Specification	Quantity
1	Trinocular Upright Metallurgical Microscope:	Coaxial Body • Body: Trinocular Head inclined at 45-degrees. • Focusing: Both side co-axial focusing knobs. • Nose piece: Quadruple revolving nosepiece with accurate centering & amp; positive click stops.	01
2	Trinocular Inverted Metallurgical Microscope	(Magnification 100X, 200X, 400X &800X) Eyepieces - WF 10X, 20X (Paired) Objectives - M 5x, M 10x, M 20x and M 40x(SL) Stage - Built-in graduated mechanical stage of size 165mm.x180mm. is controlled by convenient low coaxial positioned knobs for easy and smooth scanning of specimen.	01
3	Standard cast iron Specimen	Rectangular shape 25 mm x 25 c/s area or circular shape of 25 mm diameter or as per the availability White cast iron, Grey cast iron, Malleable cast iron, Ductile cast iron	5 specimen

VIII. Precautions to be Followed

- Wear safety goggles to protect eyes from flying debris during sample preparation.
- Use gloves to protect hands from sharp edges and chemicals.
- Wear a lab coat or apron to protect clothing from contamination
- Handle etchants (e.g., nital, picral) with care, using appropriate PPE such as gloves and goggles.
- Work in a well-ventilated area or fume hood to avoid inhaling harmful fumes from chemicals.
- Store chemicals properly and dispose of waste according to safety guidelines.
- All specimens are cut to a suitable size, and the smaller specimens mounted in thermo-plastic resin in a mould.
- Sanding is done using successive grades of waxed emery paper, finishing at grade 000.
- Polishing is done on a polishing machine, using a paste of magnesium oxide on velvet cloth.
- Etching is carried out with the reagent Nital, 4% Nitric Acid in Alcohol.
- Start with a low magnification to locate areas of interest, and then switch to higher magnifications for detailed analysis.
- Take multiple images to document different areas and features of the microstructure.

IX. Procedure

- Choose a portion of the cast iron that represents the overall structure.
- Use an abrasive cut-off wheel or a saw to cut a small section (typically a few millimeters thick) from the cast iron component. Ensure minimal heat generation to avoid altering the microstructure.
- Place the cut sample in a mounting press with a suitable mounting material (e.g., Bakelite, epoxy). This provides a uniform size and shape for easier handling and polishing.
- Start with a coarse abrasive (e.g., 240 grit) to remove saw marks and achieve a flat surface. Use a rotating grinding wheel and apply water to cool the sample and remove debris.
- Progress through finer grits (e.g., 320, 400, 600 grit) to further refine the surface, ensuring each step removes the scratches from the previous grit.
- Use a polishing wheel with a suspension of fine diamond particles (e.g., 6 μm) to remove the final grinding scratches.
- Use a finer diamond suspension (e.g., 1 μm) or colloidal silica to achieve a mirror-like finish. Ensure the surface is scratch-free and reflective.
- Rinse the polished sample with water and then with ethanol to remove any polishing residues.
- Immerse the polished sample in an appropriate etchant (e.g., 2% nital for iron) for a few seconds to reveal the microstructure. Rinse the sample immediately with water and ethanol, and then dry it with warm air.
- Use the low magnification to scan the sample surface and locate areas of interest.
- Switch to higher magnifications (e.g., 20x, 50x, 100x) to examine finer details of the microstructure.
- Draw the microstructure and analyze the properties.

X. Observations (Draw microstructure & state properties)

XI. Results

S.N.	Specimen	Shape	Size	Color	Distribution
1	Grey cast iron				
2	Nodular (ductile) Cast iron				
3	White cast iron				
4	Malleable cast iron				

XII. Interpretation of Results

XIII. Conclusions and Recommendation

XIV. Practical Related Questions

Note: Below given are few sample questions for reference. Teachers must design more such questions so as to ensure the achievement of identified CO.

1. Based on the observed microstructure of the cast iron sample, can you determine the carbon content of the cast iron? If yes, then briefly explain how you can determine the carbon content.
2. State the type of cast iron is more ductile in comparison to others.
3. On the basis of microstructure, explain why gray cast iron is brittle and weak in tension?
4. Is it possible to produce malleable cast iron in pieces having large cross sectional dimensions. Explain the reason.
5. Compare gray and malleable cast irons with respect to (a) Microstructure and (b) Mechanical characteristics.
6. Explain the significance of graphite morphology in the microstructure of ductile cast iron and its impact on the material's mechanical behavior.
7. Explain factors influencing the formation of different microstructures in cast iron during solidification and cooling processes.
8. Explain the role of alloying elements such as silicon, carbon, and manganese in controlling the microstructure and properties of cast iron.
9. Explain the microstructural features that are commonly observed in as-cast and heat-treated cast iron specimens, and their implications for material performance.
10. State examples of applications where the interpretation of cast iron microstructures is critical for ensuring product quality and performance.

[Space for Answer]

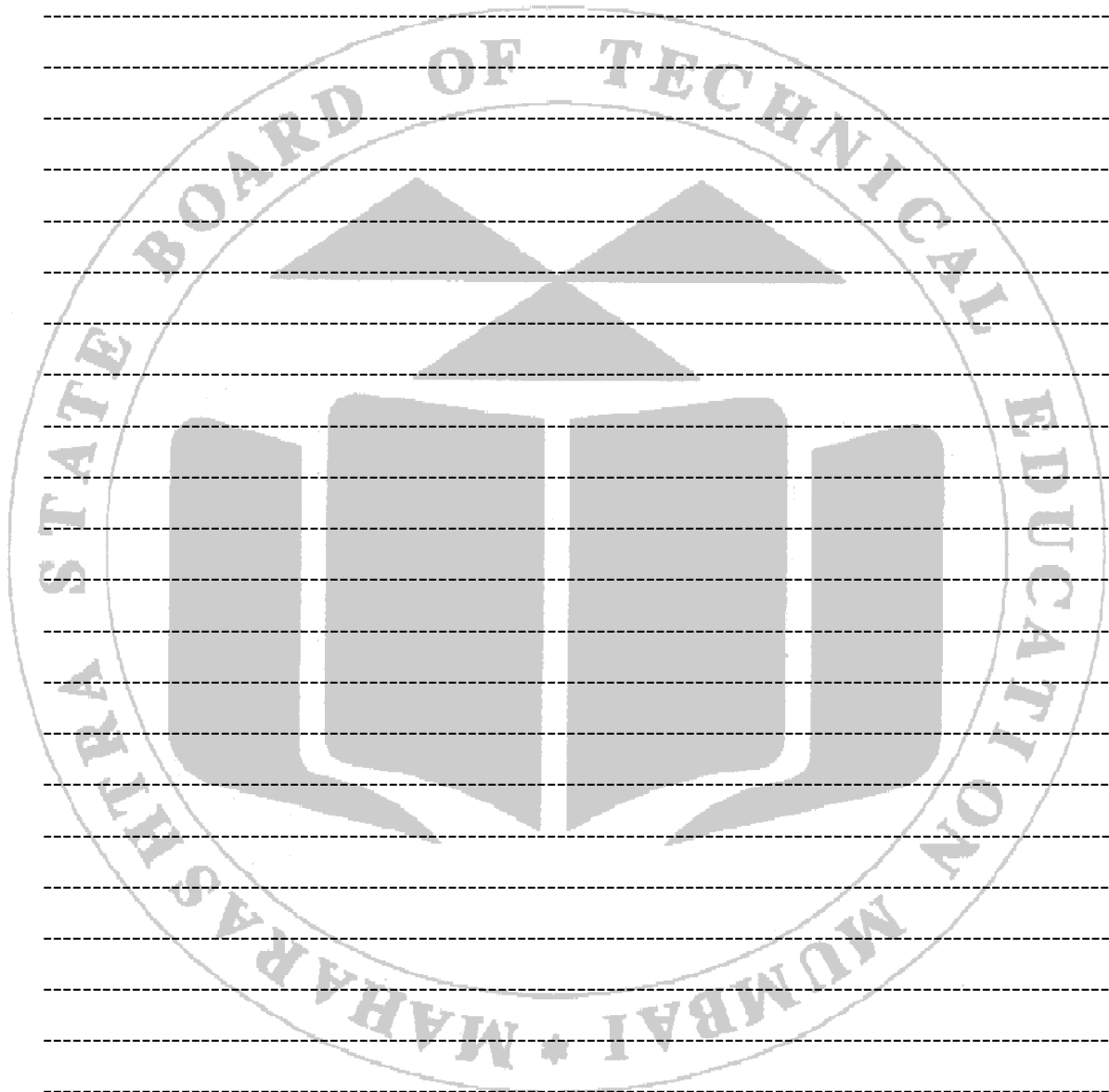

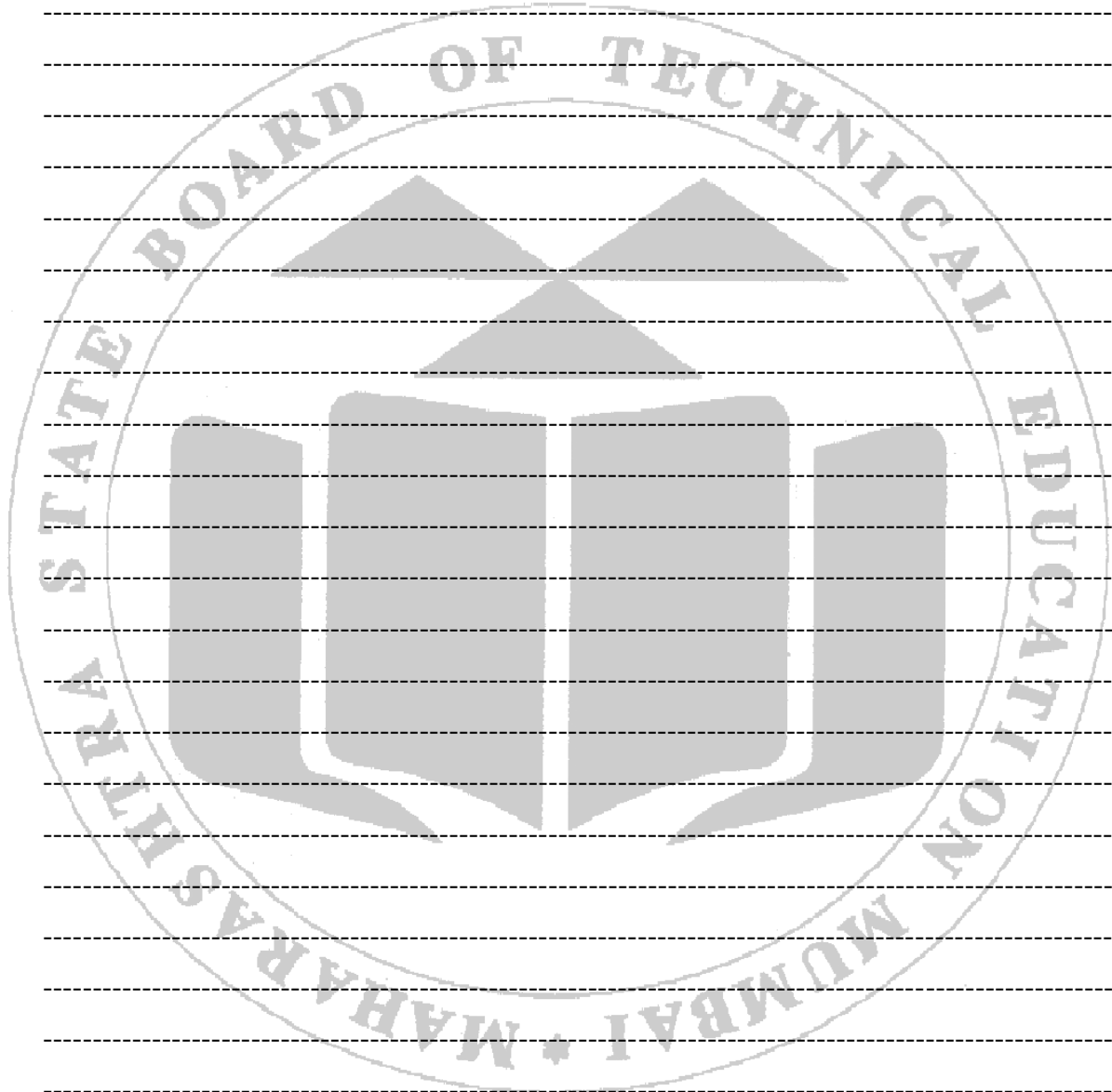

XV. References / Suggestions for Further Reading

- <https://www.youtube.com/watch?v=are5impXltM>
- <https://www.youtube.com/watch?v=LznZz380UCk>

- https://www.youtube.com/watch?v=_UtPvltK38w
- <https://www.youtube.com/watch?v=b2PCJ5s-iyk>
- https://www.youtube.com/watch?v=Jx_ZjY-u2rk

XVII Rubrics for Assessment Scheme

Performance indicators		Weightage
Product related (15 Marks)		60%
1	Preparation of experimental set up	20
2	Etching the specimen with suitable etchant	20
3	Observation of the microstructure of the specimen at different magnification using microscope	20
Process related (10 Marks)		40%
4	Follow Safety measures	10
5	Answer experiment related questions	10
6	Submit journal report on time	10
7	Follow Housekeeping	10
Total (25Marks)		100%

Marks Obtained			Dated signature of Teacher
Process Related(15)	Product Related(10)	Total (25)	

Practical No. 08: Hardness Testing On Relevant Hardness Testers Of given Copper and Brass Specimens.

I. Practical Significance

Hardness Testing provides useful information, which can be correlated to tensile strength, wear resistance, ductility, and other physical characteristics.

Hardness testing is therefore useful for

monitoring quality control and for the materials selection process. Versatile for both micro and macro hardness testing. High precision and useful for thin specimens or coatings. Provides detailed information about hardness variations in copper and brass. Detects variations in material properties due to processing, such as work hardening or annealing. Hardness testing of copper and brass using Brinell, Rockwell provides essential insights into their mechanical properties and suitability for various applications.

II. Industry/Employer Expected Outcome (s)

This practical is expected to develop the following skills for the industry/Employer

1. Ensures employees can effectively operate and maintain testing equipment.
2. Understanding how various manufacturing processes affect material hardness.
3. Reduces errors in test results, leading to more reliable quality control.

III. Course Level Learning Outcome (CO)

- CO1 - Select suitable material(s) based on desired properties according to application.
- CO3 - Select relevant nonferrous & powder material components for the engineering application.

IV. Laboratory Learning Outcome(s)

- Choose appropriate hardness testers for copper & Brass.
- Use appropriate hardness testers for copper & Brass.

V. Relative Affective Domain related Outcome(s)-

- Follow safety practices.
- Practice good housekeeping.
- Demonstrate working as a leader/a team member.
- Maintain tools and equipment.

VI. Minimum Theoretical Background

Hardness of a material is generally defined as resistance to the permanent indentation under static and dynamic load. When a material is required to use under direct static or dynamic loads, only indentation hardness test will be useful to find out resistance to indentation.

Brinell hardness test a hard steel or carbide ball indenter is pressed into the material under a specified load. The diameter of the indentation is measured, and the hardness is calculated using the formula:

$$\text{BHN} = \frac{2P}{\pi D(D - \sqrt{D^2 - d^2})}$$

Where:

P is the applied load (in kgf).

D is the diameter of the indenter (in mm).

d is the diameter of the indentation (in mm).

The Rockwell hardness test procedure of copper covers thirty different tests (scales) with various loads and indenter configurations. The most common Rockwell scales, B and C, are used for copper alloys only when the part thickness is greater than 0.04 inch (1 mm). A ball or conical diamond indenter is used. The depth of indentation under a major load is measured from a baseline set by a minor load. For copper and brass, the B scale (HRB) is commonly used with a 1/16" steel ball and a 100 kgf load. The hardness number is read directly from the machine. Pure copper has relatively low hardness but is highly ductile and conductive. Hardness can vary with alloying and work hardening. An alloy of copper and zinc, brass typically has higher hardness than pure copper. Its hardness can vary widely depending on the composition and processing.

VII. Experimental setup

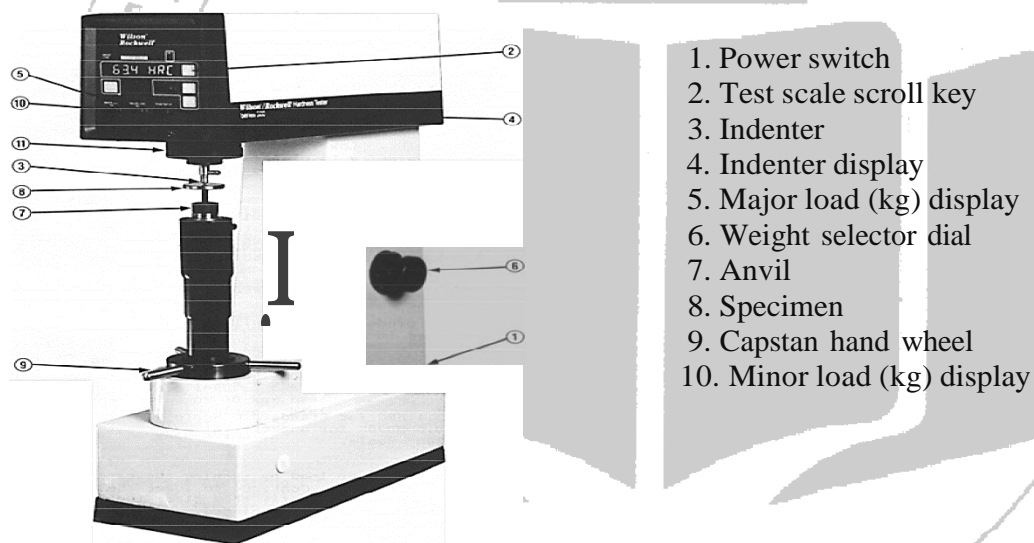

Fig.8.1 Rockwell Hardness Tester

Rockwell B Hardness Test

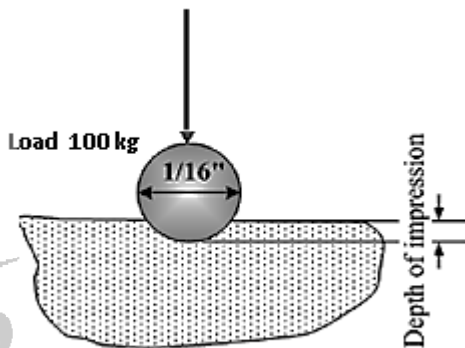
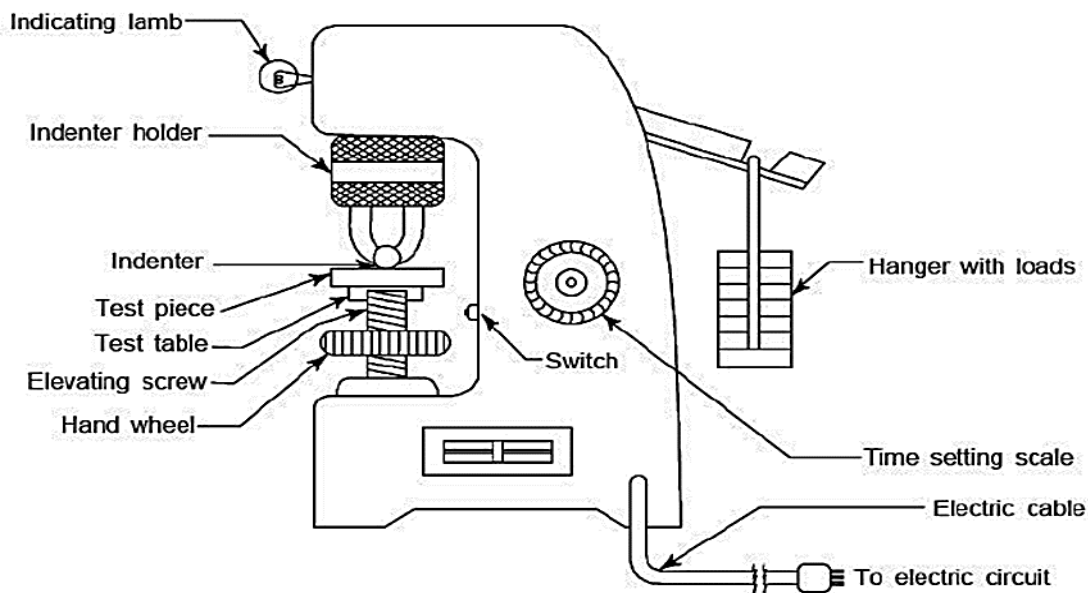
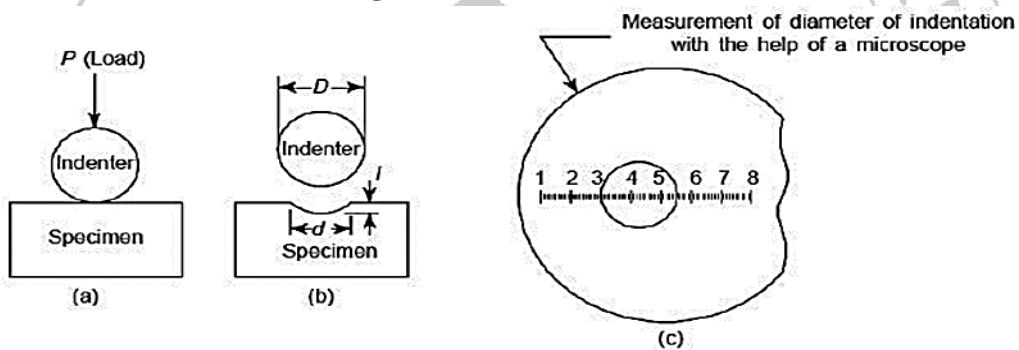

Fig.8.2 Indentation



Brinell hardness testing machine

Fig-8.3 Brinell hardness testing Machine

VIII. Required Resources /Apparatus/Equipment with specification

Sr. No.	Instrument /Components	Specification	Quantity
1.	Brinell hardness tester	1) Test loads - 500 to 3000 Kgf. in steps of 250 Kg. 2) Magnification of objective - 14 X 3) Maximum test height - 380 mm. 4) Least count -0.001 mm. 5) Throat depth - 200 mm.	01
2.	Rockwell hardness tester	1) Test loads - 60, 100 & 150 kgf 2) Minor load - 10 kg 3) Max test height - 230 mm 4) Throat depth - 133 mm along with essential accessories	01
3.	Copper Specimen	Rectangular shape 25 mm x 25 c/s area or circular shape 25 mm diameter or as per the availability	02
4	Brass specimen	Rectangular shape 25 mm x 25 c/s area or circular shape 25 mm diameter or as per the availability	02

IX. Precautions to be Followed

- Ensure the surface of the specimens is clean, smooth, and free from any contaminants, oxides, or surface irregularities. Polishing the surface to a mirror finish is often recommended.
- The specimens should have an adequate thickness to prevent deformation of the material during the test. Typically, the thickness should be at least ten times the depth of the indentation.
- Perform the test at a standard room temperature, avoiding extreme temperatures that could affect the material properties.
- Conduct the test in a clean environment to avoid any contamination of the specimens or the testing machine.
- Ensure the hardness testing machine is properly calibrated before starting the test. Regular calibration checks are essential for accurate results.
- Verify that the indenters are in good condition, with no wear or damage. Use the appropriate indenter for the specific hardness test (e.g., Brinell, Rockwell, Vickers).
- Apply the test load smoothly and without impact to avoid any additional stresses on the material.
- Align the specimen correctly under the indenter to ensure a perpendicular application of the load.
- Adhere to the specified load holding time for the test being performed. Different hardness tests have different requirements for load application and duration.
- Conduct multiple hardness measurements on different areas of the specimen to obtain an average value, reducing the effect of localized material anomalies.
- Due to copper's high ductility, avoid using excessive loads that could cause plastic deformation. Ensure the surface is well-polished to reduce the influence of surface roughness on the test results
- Brass is more susceptible to dezincification, which can affect its hardness. Ensure that the specimens are free from any surface corrosion or degradation before testing.

- Do not apply excessive load on specimen. Use 50.0 kg load for hardness testing of soft alloys using Brinell hardness tester.
- Select the appropriate scale if using Rockwell hardness tester
- Specimen thickness should be 10 times higher than the depth of the indenter
- The spacing between the indentations should be 3 to 5 times of the indentation diameter
- Loading speed should be standardized.

X. Procedure

For Rockwell hardening Test

1. Ensure the surface of the specimen is clean, smooth, and free of any contaminants, oxides, or debris. Polishing to a mirror finish is recommended to achieve a consistent surface.
2. Ensure that the specimen is of adequate thickness, generally at least ten times the depth of the indentation to avoid any substrate influence on the measurement.
3. Verify that the Rockwell hardness tester is properly calibrated according to the manufacturer's specifications. Regular calibration checks are essential to maintain accuracy.
4. Select the appropriate indenter (diamond cone for Rockwell C scale or steel ball for Rockwell B scale) and ensure it is in good condition without any wear or damage.
5. Secure the specimen on the testing anvil, ensuring it is stable and aligned perpendicularly under the indenter.
6. Apply the preliminary test load (typically 10 kgf) to the specimen. This initial load helps seat the indenter and establishes a zero reference position.
7. After the preliminary load is applied, incrementally apply the major test load (an additional load, typically 100 kgf for Rockwell B scale or 150 kgf for Rockwell C scale) smoothly and without impact.
8. Hold the major load for a specified duration to ensure accurate indentation. The hold time is typically around 2 to 6 seconds.
9. After holding the major load for the required duration, release it smoothly while maintaining the preliminary load. The Rockwell hardness number is then automatically indicated by the machine.
10. Record the hardness value displayed by the Rockwell hardness tester. This value is based on the depth of indentation caused by the applied loads.
11. To ensure reliability, perform multiple hardness measurements at different locations on the specimen, especially if the material is suspected to have inhomogeneities. Typically, at least three measurements are recommended, and then calculate the average hardness value.
12. Check for any signs of cracking or deformation around the indentation, which could affect the hardness reading.
13. Copper is relatively soft and ductile, so it is typically tested using the Rockwell B scale (steel ball indenter, 100 kgf major load). Ensure the surface is well-prepared to minimize the effect of surface roughness.
14. Brass can vary in hardness based on its composition (e.g., alpha brass, alpha-beta brass). Typically, the Rockwell B scale is used, but for harder brass alloys, the Rockwell C scale might be appropriate. Check for any signs of dezincification, which can affect hardness.

For Brinell Test

1. Ensure the specimen surface is clean, free from dirt, oil, and other contaminants.

2. Polish the surface to remove any scratches or irregularities. A smooth, uniform surface is essential for accurate readings.
3. Ensure the specimen is thick enough to prevent the indenter from contacting the back of the specimen. The thickness should be at least ten times the depth of the indentation.
4. Verify that the Brinell hardness tester is properly calibrated according to the manufacturer's specifications. Use standard reference blocks to check for accuracy.
5. Use a hardened steel or carbide ball indenter, typically 10 mm in diameter.
6. For copper and brass, a common load is 500 kgf, but this can vary depending on the specific material properties and standards being followed. For soft materials like copper, lighter loads (e.g., 250 kgf) might be used.
7. Place the specimen on the anvil of the Brinell hardness tester. Ensure it is stable and properly aligned under the indenter.
8. Gradually apply the test load (e.g., 500 kgf) to the specimen. Ensure the load is applied smoothly to avoid shock loading.
9. Maintain the load for a specific duration (typically 10 to 15 seconds) to allow for a consistent indentation
10. After the dwell time, smoothly release the load.
11. After the load is released, examine the indentation for consistency and clarity. The indentation should be well-defined and free from irregularities.
12. Use a microscope with a calibrated scale or an optical measuring system to measure the diameter of the indentation. Take two measurements at right angles to each other and average them to obtain the final diameter.
13. Conduct multiple hardness measurements at different locations on the specimen to account for any material inconsistencies. Calculate the average BHN from these measurements.
14. Copper is relatively soft, so lighter loads (e.g., 250 kgf) might be used to prevent excessive indentation and ensure accuracy.
15. Brass hardness can vary depending on its composition. Use appropriate loads to ensure clear, accurate indentations without causing material deformation or work hardening.

**XI. Observation Tables-
Brinell hardness measurement**

SR No	Specimen	Indenter Diameter (D)	Total Load(P) Kgf	Diameter of Indentation (d) mm			Avg. Diameter d avg.	BHN
				1	2	3		
1	Copper Specimen	hardened steel or carbide ball indenter 10 mm in diameter						
2	Brass Specimen	hardened steel or carbide ball indenter 10 mm in diameter						

Rockwell harness number

SR No	Specimen	Type of Indenter	Rockwell Hardness Number(RHN)			Avg. RHN
			1	2	3	
1	Copper Specimen	diamond cone for C scale or steel ball for B scale				
2	Brass Specimen	diamond cone for C scale or steel ball for B scale				

Calculations

For Brinell Hardness-

$$\text{BHN} = \frac{2P}{\pi D(D - \sqrt{D^2 - d^2})}$$

The formulas used for calculating Rockwell Hardness values are as follows:

For regular Rockwell Hardness using spheroconical "Brale" Indenter

$$\text{HR [Scale]} = 100 - \left(\frac{h}{0.002} \right)$$

Where Scale is A, C, D and h is the depth penetrated in mm. For regular Rockwell Hardness using a steel ball

$$HR[\text{Scale}] = 130 - \left(\frac{h}{0.002}\right)$$

Where Scale is B, E, F, G etc. and h is in mm

OR

In Rockwell B (HRB) and Rockwell C (HRC):

$$HR = E - e$$

Where:

E is a constant based on the Rockwell scale used (e.g., 130 for HRC, 100 for HRB).

e is the depth of indentation under the major load, measured in units of 0.002 mm (0.00008 inches).

For Rockwell C scale (HRC):

$$HRC = 100 - h$$

Where h is the depth difference in 0.002 mm units after applying the major load.

For Rockwell B scale (HRB):

$$HRB = 130 - h$$

Where h is the depth difference in 0.002 mm units after applying the major load.

XII. Results

The hardness of copper is 1) BHN----- 2) RHN-----

The hardness of brass is 1) BHN----- 2) RHN-----

XIII. Interpretation of Results

XIV. Conclusions and Recommendation

XV. Practical Related Questions

Note: Below given are few sample questions for reference. Teachers must design more such questions so as to ensure the achievement of identified CO.

1. Define Hardness.
2. State the applications of Rockwell Hardness A - Scale, B-Scale, C-Scale.
3. State the type of indenter used in the three different scales of 'Rockwell Hardness Test'.
4. List the different types of hardness testing methods.
5. State the size of the ball to be used in 'Ball Indenter' of 'Rockwell Hardness Test'.
6. State the diameters of the different balls used in 'Brinell Hardness Test'.
7. State the selection of load in 'Brinell Hardness Test'.
8. State the selection of load in 'Rockwell Hardness Test'.
9. Explain the common hardness testing methods used for assessing the hardness of both copper and brass materials?
10. Explain how can hardness testing results be correlated with the mechanical properties of copper materials, such as tensile strength and yield strength.
11. Explain limitations of the Brinell hardness test when applied to both copper and brass, and how can they be mitigated.
12. Explain factors should be considered when selecting an appropriate indentation load for hardness testing copper and brass materials.

[Space for Answer]

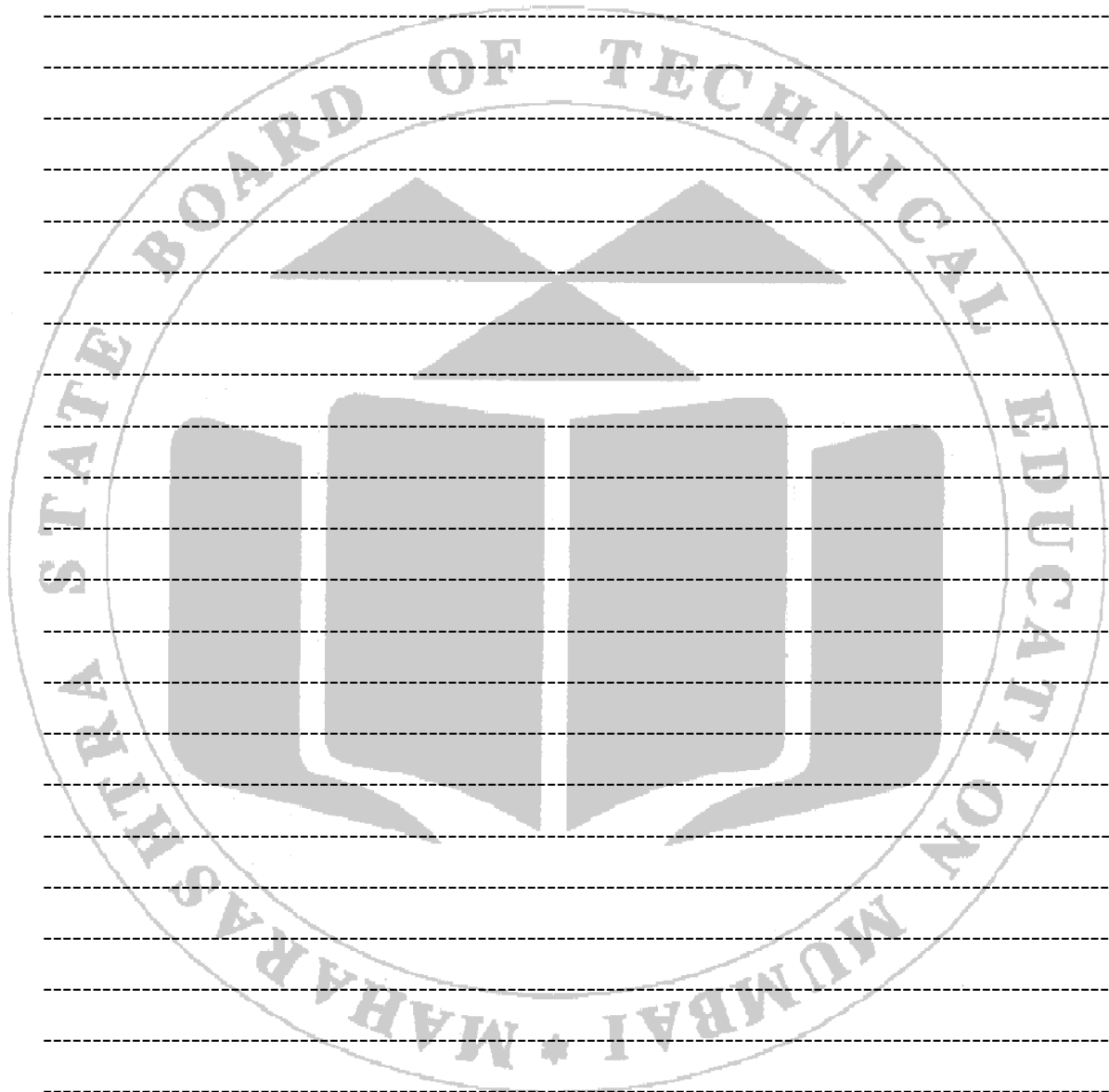

XVI. References / Suggestions for Further Reading

- <https://www.youtube.com/watch?v=i1x-vJ85sBA>
- <https://www.youtube.com/watch?v=ysinnHOoouc>
- https://www.youtube.com/watch?v=NIWV mp_q_XE
- <https://www.youtube.com/watch?v=RJXJpeH78iU>
- <https://www.youtube.com/watch?v=G2JGNlivNC4>

XVII. Rubrics for Assessment Scheme

Performance indicators		Weightage
Process related (15 Marks)		60%
1	Handling of hardness tester	20
2	Mounting of specimen	20
3	Hardness testing	20
Product related (10 Marks)		40%
4	Specimen tested	10
5	Interpretation of result	10
6	Conclusions	10
7	Practical related questions	10
Total (25Marks)		100%

Marks Obtained			Dated signature of Teacher
Process Related(15)	Product Related(10)	Total (25)	

Practical No. 09: Hardness Testing On Relevant Hardness Testers of given Aluminum Specimens.

I. Practical Significance

Hardness Testing provides useful information, which can be correlated to tensile strength, wear resistance, ductility, and other physical characteristics. Hardness testing is therefore useful for monitoring quality control and for the materials selection process. Versatile for both micro and macro hardness testing. Each hardness testing method provides unique insights into the mechanical properties of aluminum specimens, with practical applications ranging from industrial quality control to advanced materials research. The choice of test depends on the specific requirements of the application, such as the size and type of the aluminum sample, the precision needed, and whether the testing process should be non-destructive. Understanding the significance of these tests helps in selecting the right method to ensure material performance and reliability in various engineering applications.

II. Industry/Employer Expected Outcome (s)

This practical is expected to develop the following skills for the industry/Employer

1. Implement standard operating procedures for hardness testing.
2. Evaluate the performance and suitability of aluminum materials for different industrial applications.
3. Develop solutions to improve material properties based on hardness test results.

III. Course Level Learning Outcome (CO)

- CO1 - Select suitable material(s) based on desired properties according to application.
- CO3 - Select relevant nonferrous & powder material components for the engineering application.

IV. Laboratory Learning Outcome(s)

- Choose appropriate hardness testers for Aluminum.
- Use appropriate hardness testers for Aluminum.

V. Relative Affective Domain related Outcome(s)-

- Follow safety practices.
- Practice good housekeeping.
- Demonstrate working as a leader/a team member.
- Maintain tools and equipment.

VI. Minimum Theoretical Background with diagram

Hardness of a material is generally defined as resistance to the permanent indentation under static and dynamic load. When a material is required to use under direct static or dynamic loads, only indentation hardness test will be useful to find out resistance to indentation.

Brinell hardness test a hard steel or carbide ball indenter is pressed into the material under a specified load. The diameter of the indentation is measured, and the hardness is calculated using the formula:

$$\text{BHN} = \frac{2P}{\pi D(D - \sqrt{D^2 - d^2})}$$

Where:

P is the applied load (in kgf).

D is the diameter of the indenter (in mm).

d is the diameter of the indentation (in mm).

Alloying and heat treatment can significantly affect the hardness and other mechanical properties of aluminum. The choice of indenter and load depends on the Rockwell scale suitable for the aluminum specimen being tested. Different Rockwell scales (e.g., B and E) are used for aluminum: Rockwell B (HRB): Uses a 1/16-inch steel ball indenter and a 100 kgf major load. Rockwell E (HRE): Uses a 1/8-inch steel ball indenter and a 100 kgf major load. Measures the depth of penetration of an indenter under a minor and a major load. Indenters used Diamond Cone for harder materials and Steel Ball for softer materials like aluminum. Apply a minor load (usually 10 kgf) to seat the indenter. Use hardness values to determine the suitability of aluminum for specific applications, such as automotive components, aerospace structures, and consumer goods.

VII. Experimental setup

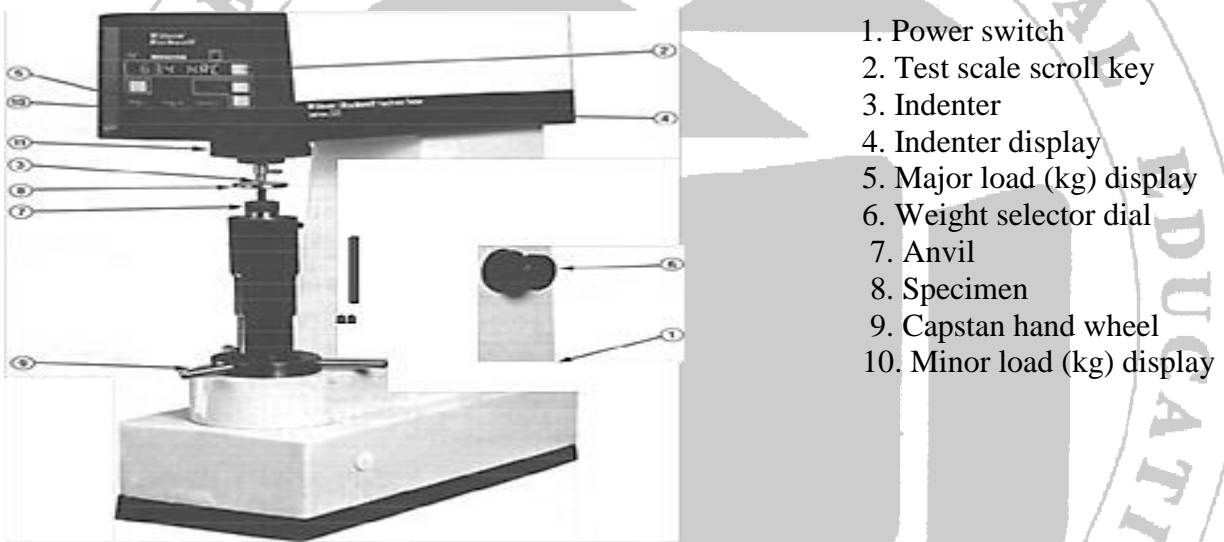

Fig 9.1 Rockwell Hardness Tester

Rockwell B Hardness Test

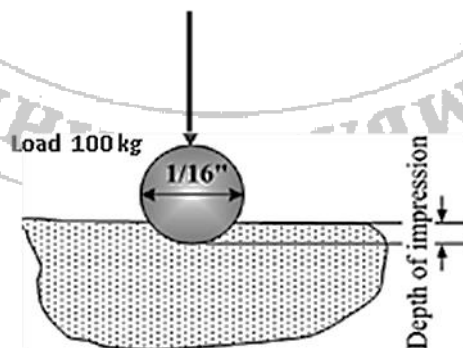

Fig 9.2 Indentation

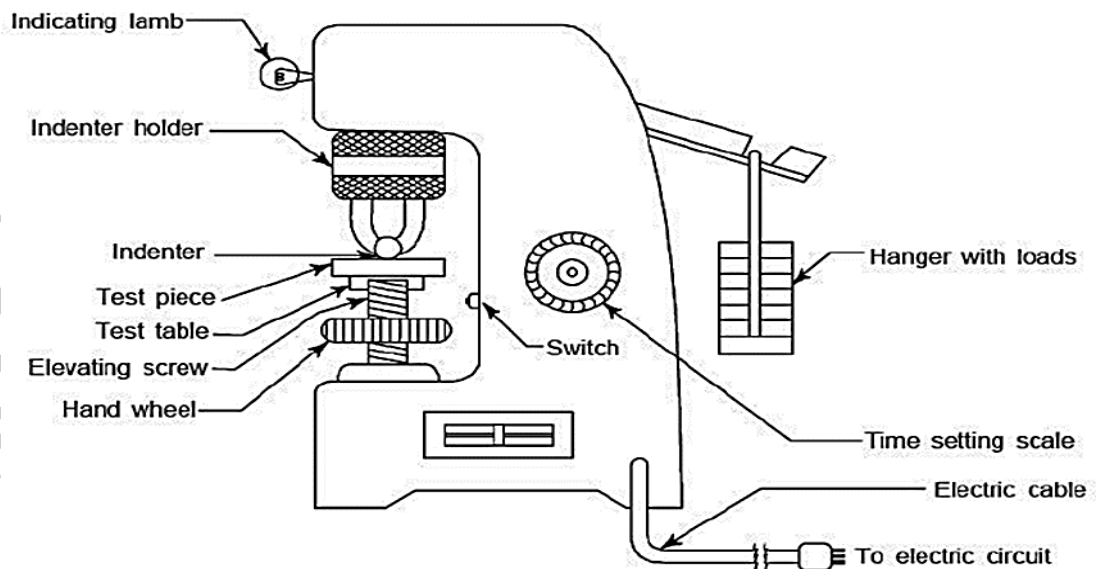
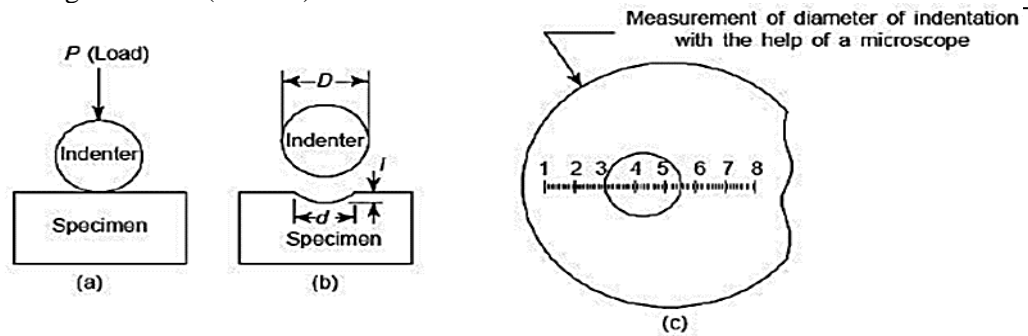

Fig 9.3 Brinell hardness testing Machine

VIII. Required Resources /Apparatus/Equipment with specification

Sr. No.	Instrument /Components	Specification	Quantity
1.	Brinell hardness tester	1) Test loads - 500 to 3000 Kgf. in steps of 250 Kg. 2) Magnification of objective - 14 X 3) Maximum test height - 380 mm. 4) Least count -0.001 mm. 5) Throat depth - 200 mm.	01
2.	Rockwell hardness tester	1) Test loads - 60, 100 & 150 kgf 2) Minor load - 10 kg 3) Max test height - 230 mm 4) Throat depth - 133 mm along with essential accessories	01
3.	Aluminium Specimen	Rectangular shape 25 mm x 25 c/s area or circular shape 25 mm diameter or as per the availability	02

IX. Precautions to be Followed

- Ensure the surface of the specimens is clean, smooth, and free from any contaminants, oxides, or surface irregularities. Polishing the surface to a mirror finish is often recommended.
- The specimens should have an adequate thickness to prevent deformation of the material during the test. Typically, the thickness should be at least ten times the depth of the indentation.
- Perform the test at a standard room temperature, avoiding extreme temperatures that could affect the material properties.
- Conduct the test in a clean environment to avoid any contamination of the specimens or the testing machine.
- Ensure the hardness testing machine is properly calibrated before starting the test. Regular calibration checks are essential for accurate results.
- Verify that the indenters are in good condition, with no wear or damage. Use the appropriate indenter for the specific hardness test (e.g., Brinell, Rockwell).
- Apply the test load smoothly and without impact to avoid any additional stresses on the material.
- Align the specimen correctly under the indenter to ensure a perpendicular application of the load.
- Adhere to the specified load holding time for the test being performed. Different hardness tests have different requirements for load application and duration.
- Conduct multiple hardness measurements on different areas of the specimen to obtain an average value, reducing the effect of localized material anomalies.
- Due to copper's high ductility, avoid using excessive loads that could cause plastic deformation. Ensure the surface is well-polished to reduce the influence of surface roughness on the test results.
- Brass is more susceptible to dezincification, which can affect its hardness. Ensure that the specimens are free from any surface corrosion or degradation before testing.
- Do not apply excessive load on specimen. Use 50.0 kg load for hardness testing of soft alloys using Brinell hardness tester.
- Select the appropriate scale if using Rockwell hardness tester.
- Specimen thickness should be 10 times higher than the depth of the indenter.
- The spacing between the indentations should be 3 to 5 times of the indentation diameter.
- Loading speed should be standardized.

X. Procedure

For Rockwell hardening Test

1. Ensure the surface of the specimen is clean, smooth, and free of any contaminants, oxides, or debris. Polishing to a mirror finish is recommended to achieve a consistent surface.
2. Ensure that the specimen is of adequate thickness, generally at least ten times the depth of the indentation to avoid any substrate influence on the measurement.
3. Verify that the Rockwell hardness tester is properly calibrated according to the manufacturer's specifications. Regular calibration checks are essential to maintain accuracy.
4. Select the appropriate indenter (diamond cone for Rockwell C scale or steel ball for Rockwell B scale) and ensure it is in good condition without any wear or damage.

5. Secure the specimen on the testing anvil, ensuring it is stable and aligned perpendicularly under the indenter.
6. Apply the preliminary test load (typically 10 kgf) to the specimen. This initial load helps seat the indenter and establishes a zero reference position.
7. After the preliminary load is applied, incrementally apply the major test load (an additional load, typically 100 kgf for Rockwell B scale or 150 kgf for Rockwell C scale) smoothly and without impact.
8. Hold the major load for a specified duration to ensure accurate indentation. The hold time is typically around 2 to 6 seconds.
9. After holding the major load for the required duration, release it smoothly while maintaining the preliminary load. The Rockwell hardness number is then automatically indicated by the machine.
10. Record the hardness value displayed by the Rockwell hardness tester. This value is based on the depth of indentation caused by the applied loads.
11. To ensure reliability, perform multiple hardness measurements at different locations on the specimen, especially if the material is suspected to have inhomogeneities. Typically, at least three measurements are recommended, and then calculate the average hardness value.
12. Check for any signs of cracking or deformation around the indentation, which could affect the hardness reading.
13. Copper is relatively soft and ductile, so it is typically tested using the Rockwell B scale (steel ball indenter, 100 kgf major load). Ensure the surface is well-prepared to minimize the effect of surface roughness.
14. Brass can vary in hardness based on its composition (e.g., alpha brass, alpha-beta brass). Typically, the Rockwell B scale is used, but for harder brass alloys, the Rockwell C scale might be appropriate. Check for any signs of dezincification, which can affect hardness.

For Brinell Test

1. Ensure the specimen surface is clean, free from dirt, oil, and other contaminants.
2. Polish the surface to remove any scratches or irregularities. A smooth, uniform surface is essential for accurate readings.
3. Ensure the specimen is thick enough to prevent the indenter from contacting the back of the specimen. The thickness should be at least ten times the depth of the indentation.
4. Verify that the Brinell hardness tester is properly calibrated according to the manufacturer's specifications. Use standard reference blocks to check for accuracy.
5. Use a hardened steel or carbide ball indenter, typically 10 mm in diameter.
6. For copper and brass, a common load is 500 kgf, but this can vary depending on the specific material properties and standards being followed. For soft materials like copper, lighter loads (e.g., 250 kgf) might be used.
7. Place the specimen on the anvil of the Brinell hardness tester. Ensure it is stable and properly aligned under the indenter.
8. Gradually apply the test load (e.g., 500 kgf) to the specimen. Ensure the load is applied smoothly to avoid shock loading.
9. Maintain the load for a specific duration (typically 10 to 15 seconds) to allow for a consistent indentation.
10. After the dwell time, smoothly release the load.

11. After the load is released, examine the indentation for consistency and clarity. The indentation should be well-defined and free from irregularities.
12. Use a microscope with a calibrated scale or an optical measuring system to measure the diameter of the indentation. Take two measurements at right angles to each other and average them to obtain the final diameter.
13. Conduct multiple hardness measurements at different locations on the specimen to account for any material inconsistencies. Calculate the average BHN from these measurements.
14. Copper is relatively soft, so lighter loads (e.g., 250 kgf) might be used to prevent excessive indentation and ensure accuracy.
15. Brass hardness can vary depending on its composition. Use appropriate loads to ensure clear, accurate indentations without causing material deformation or work hardening.

XI.Observation Tables-

Brinell hardness measurement

SR No	Specimen	Indenter Diameter (D)	Total Load(P) Kgf	Diameter of Indentation (d) mm			Avg. Diameter d avg.	BHN
				1	2	3		
1	Copper Specimen	hardened steel or carbide ball indenter 10 mm in diameter						
2	Brass Specimen	hardened steel or carbide ball indenter 10 mm in diameter						

Rockwell harness number

SR No	Specimen	Type of Indenter	Rockwell Hardness Number(RHN)			Avg. RHN
			1	2	3	
1	Copper Specimen	diamond cone for C scale or steel ball for B scale				
2	Brass Specimen	diamond cone for C scale or steel ball for B scale				

Calculations

For Brinell Hardness-

$$\text{BHN} = \frac{2P}{\pi D(D - \sqrt{D^2 - d^2})}$$

The formulas used for calculating Rockwell Hardness values are as follows:

For regular Rockwell Hardness using spheroconical "Brale" Indenter

$$\text{HR [Scale]} = 100 - h/0.002$$

Where Scale is A, C, D and h is the depth penetrated in mm. For regular Rockwell Hardness using a steel ball

$$\text{HR [Scale]} = 130 - h/0.002$$

Where Scale is B, E, F, G etc. and h is in mm

OR

In Rockwell B (HRB) and Rockwell C (HRC):

$$\text{HR} = E - e$$

Where:

E is a constant based on the Rockwell scale used (e.g., 130 for HRC, 100 for HRB).

e is the depth of indentation under the major load, measured in units of 0.002 mm (0.00008 inches).

For Rockwell C scale (HRC):

$$\text{HRC} = 100 - h$$

Where h is the depth difference in 0.002 mm units after applying the major load.

For Rockwell B scale (HRB):

$$HRB=130-h$$

Where h is the depth difference in 0.002 mm units after applying the major load.

XII. Results

The hardness of aluminum is 1) BHN----- 2) RHN-----

XIII. Interpretation of Results

XIV. Conclusions and Recommendation

XV. Practical Related Questions

Note: Below given are few sample questions for reference. Teachers must design more such questions so as to ensure the achievement of identified CO.

1. Explain common hardness testing methods used for assessing the hardness of aluminum materials.
2. Explain factors considered when selecting an appropriate indentation load for hardness testing aluminum materials.
3. Explain how does the thickness of aluminum specimens affect the choice of hardness testing method.
4. Explain key differences between the Brinell and Rockwell hardness testing methods, and which is more suitable for assessing the hardness of aluminum components.
5. Explain a scenario where an inappropriate hardness tester was used for aluminum and the impact it had on the results. What was the correct choice of tester in that scenario?
6. Explain how can the results obtained from hardness testing of aluminum materials be correlated with their mechanical properties and performance characteristics.

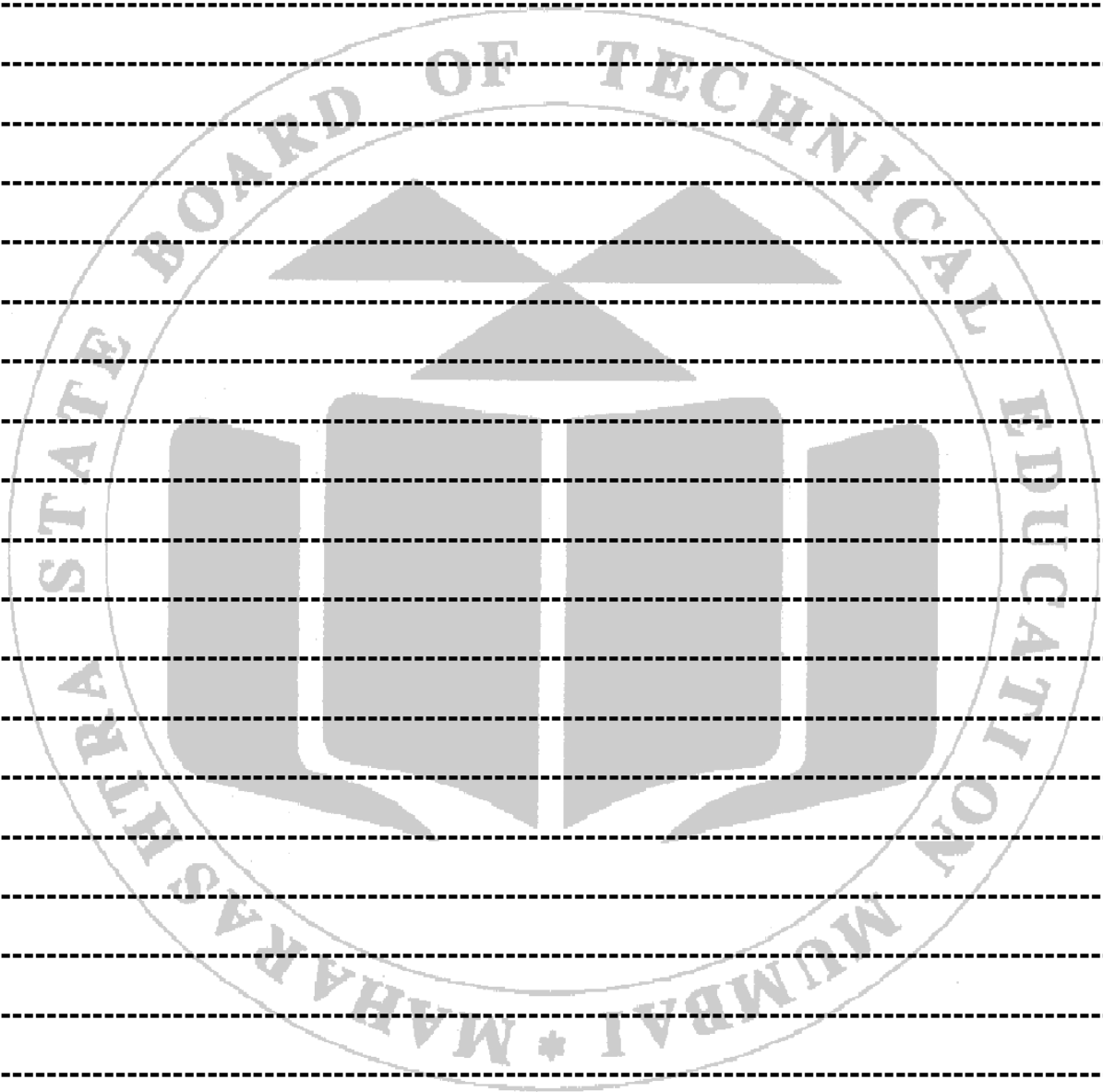

XVI. References / Suggestions for Further Reading

- <https://www.youtube.com/watch?v=i1x-vJ85sBA>
- <https://www.youtube.com/watch?v=ysinnHOoouc>
- <https://www.youtube.com/watch?v=RJXJpeH78iU>
- <https://www.youtube.com/watch?v=G2JGNlivNC4>

XVII. Rubrics for Assessment Scheme

Performance indicators		Weightage
Process related (15 Marks)		60%
1	Handling of hardness tester	20
2	Mounting of specimen	20
3	Hardness testing	20
Product related (10 Marks)		40%
4	Specimen tested	10
5	Interpretation of result	10
6	Conclusions	10
7	Practical related questions	10
Total (25Marks)		100%

Marks Obtained			Dated signature of Teacher
Process Related(15)	Product Related(10)	Total (25)	

Practical No.10: Adhesive strength determination of cellophane tape and duct tape using a relevant peel tester

I. Practical Significance

Adhesives are all around us. They come in the form of tapes, wall/window/floor decals, and glues. Millions of dollars each year are invested in purchasing these products as well as doing research to design more efficient products. The strength of these adhesives determines their use. Stronger adhesives such as duct tape leave a residue and are very difficult to remove from most surfaces. Weaker adhesives such as wall decals must be strong enough to stay on the wall but must be able to be easily removed. The strength of these adhesives is measured by doing a peel test. A peel test measures the force required to remove the adhesive from the surface.

II. Industry/Employer Expected Outcome (s)

This practical is expected to develop the following skills for the industry/ employer

1. Gaining hands-on experience with peel testers, understanding their components, and learning to operate them effectively.
2. Understanding the basic principles of material science related to adhesives
3. Evaluating the quality and performance of tape products, which is important for quality control in manufacturing and product development

III. Course Level Learning Outcome (CO)

CO3- Select relevant non ferrous & powder material components for the engineering application.

IV. Laboratory Learning Outcome(s)

- Use relevant peel tester
- Determine the adhesive strength of scotch tape, electrical tape and masking tape on a smooth surface.

V. Relative Affective Domain related Outcome(s)-

- Follow safety practices.
- Practice good housekeeping.
- Demonstrate working as a leader/a team member.
- Maintain tools and equipment.
- Follow ethical Practices

VI. Minimum Theoretical Background with diagram (if required)

Peel adhesion is defined as the force needed to "peel" an adhesive tape from any given surface, whether flexible, smooth, or rigid. This "peel" force is always and only measured across the width of the taped substrate, making it the more difficult separating force to resist. It is important to understand the peel adhesion factor, as it can serve as a guide for choosing the right tape for the application. Some of the common types of tapes are cellophane tape, duct tape, scotch tape, electrical tape and masking tape.

Duct tape is one of the most versatile tapes and they can be used for many applications like holding carpets in place, repairing hoses, binding books and even holding together parts of a broken window. They are normally used in places where long-lasting, flexible and strong adhesive is required.

VII. Experimental setup



Fig.10.1 Adhesive Tape

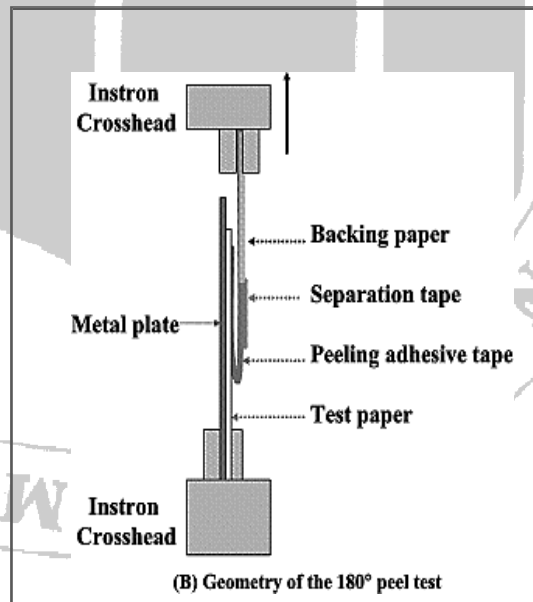
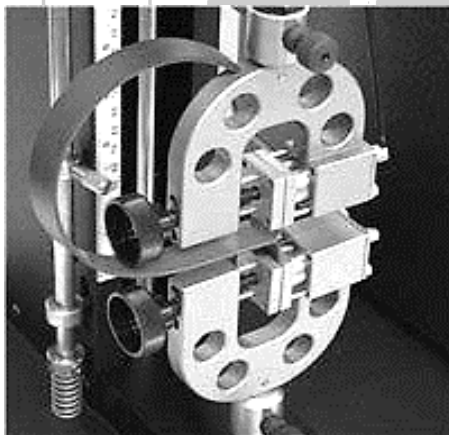

Fig.10.2. Peel Tester

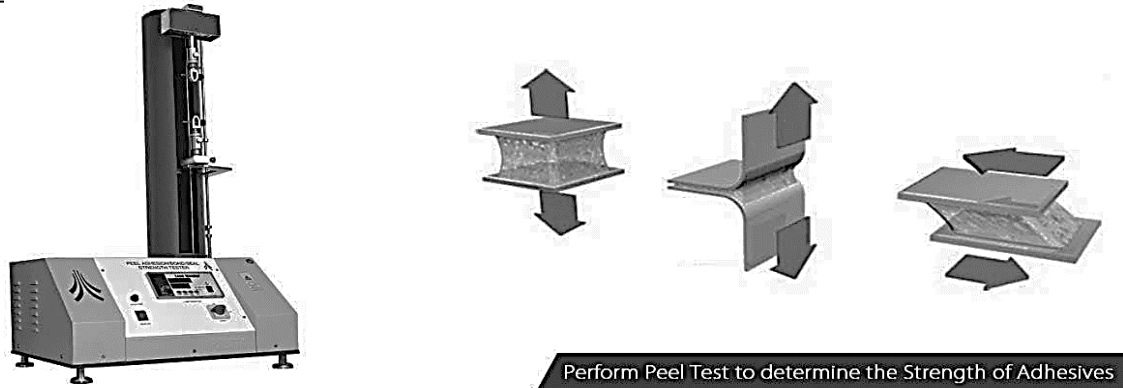

Fig.10.3. Peel Tester

VIII. Required Resources /Apparatus/Equipment with specification

Sr. No.	Instrument /Components	Specification	Quantity
1	Digital Peel Tester	Load capacity: Up to 5 kg No. of load cell: One Cross Travel: Up to 250 mm Speed: 300 mm/minute Direct display: Peak load Paint: Powder coated Power: 230 Volts, 50 Hz, single phase	01
2	Peeling Strength Tester	Capacity Range 0~200 N (30 N, 50 N and 100 N are optional) Accuracy 1% of reading value Resolution 0.01N Test Speed 50, 100, 150, 200, 250, 300, 500 mm/min Specimen Width 30 mm Stroke 500 mm	01
3	Cellophane Tape	Type: Adhesive Tape Length: 6 m	1 in group of 5
4	Duct Tape	Tape Length: 10-20 m, 40-50 m, 0-10 m, >50 m, 30-40 m, 20-30 m Tape Width: >100 mm, 80-100 mm, 0-20 mm, 20-40 mm, 60-80 mm, 40-60	1 in group of 5

IX. Precautions to be Followed

- Ensure the surface to which the tape will be adhered is clean, dry, and free of contaminants such as dust, oil, or grease. Use a solvent like isopropyl alcohol to clean the surface.
- Cut the tape samples to a consistent length and width. This ensures uniformity in testing and comparability of results.
- Allow a consistent amount of time for the tape to adhere to the surface before testing. This can be standardized based on the specific adhesive properties of the tapes.
- Ensure the peel tester is properly calibrated according to the manufacturer's instructions. Regular calibration checks are essential to maintain accuracy.
- Perform tests in a controlled environment where temperature and humidity are kept constant, as these factors can affect adhesive properties.
- Ensure the testing area is free from drafts and vibrations that could affect the stability of the peel test.
- If cutting is required during sample preparation, handle cutting tools and blades with care to avoid injury.
- Use peel tester carefully
- Apply tapes on test plate properly

X. Procedure

1. Use a solvent like isopropyl alcohol to thoroughly clean the substrate. Wipe it with a lint-free cloth to ensure it is free of contaminants such as dust, oil, or grease.
2. Cut the tape into uniform strips of a consistent length and width, typically 1 inch (25.4 mm) wide and at least 6 inches (150 mm) long.
3. Label each tape sample with an identifier to keep track of different tests
4. Place the tape onto the clean substrate. Use a roller or squeegee to apply even pressure across the tape, ensuring full contact with the substrate and eliminating air bubbles.
5. Allow the tape to adhere to the substrate for a consistent amount of time before testing. A standard waiting time might be 15 minutes to 24 hours, depending on the adhesive properties and the testing standards you are following.
6. Ensure the peel tester is calibrated according to the manufacturer's instructions.
7. Secure the substrate with the adhered tape in the peel tester's clamp. Ensure it is properly aligned and firmly held in place.
8. Peel back a small section of the tape (about 1 inch) from the substrate. Attach this free end to the peel tester's upper clamp.
9. Set the peel angle to the desired degree, typically 90 degrees or 180 degrees.
10. Set the peel speed to the standard rate, often 300 mm/min (12 in/min), but this can vary depending on the standard being followed.
11. Begin the peel test. The peel tester will pull the tape from the substrate at the set speed and angle, measuring the force required to peel the tape.
12. The peel tester will generate a force vs. distance or force vs. time curve. Record the peak force and the average peel strength.
13. Record the average force required for peeling.
14. Examine the peeled tape and substrate for any anomalies such as adhesive residue on the substrate or incomplete peeling.
15. Clean the peel tester and substrate to remove any adhesive residue before the next test.
16. Perform multiple tests (at least three replicates) for each type of tape to ensure

repeatability and accuracy of the results.

17. Calculate the average peel strength from the multiple tests conducted. This can be done by averaging the peak forces or using the area under the force vs. distance curve.

XI. Observations and calculations

Name of tape	Load (N)	Thickness (t) mm	Width (b) mm	Avg Peel Strength N/mm ²
Cellophane Tape				
Duct Tape				

Calculation: Peel Strength= Load/ Area under Load

XII. Results

- a. Adhesive strength of Cellophane is -----
- b. Adhesive strength of duct tape is -----

XIII. Interpretation of Results

XIV. Conclusions and Recommendation

XV. Practical Related Questions

Note: Below given are few sample questions for reference. Teachers must design more such questions so as to ensure the achievement of identified CO.

1. List the applications of duct tape.
2. State the five brands of cellophane tape in market.
3. State the five different commercial brands of tapes in the market.
4. Define the term 'Peel Strength'
5. State any five different adhesive tapes used in industrial applications with their specifications.
6. Explain whether the process that makes adhesive tape sticky is physical or chemical.

[Space for Answer]

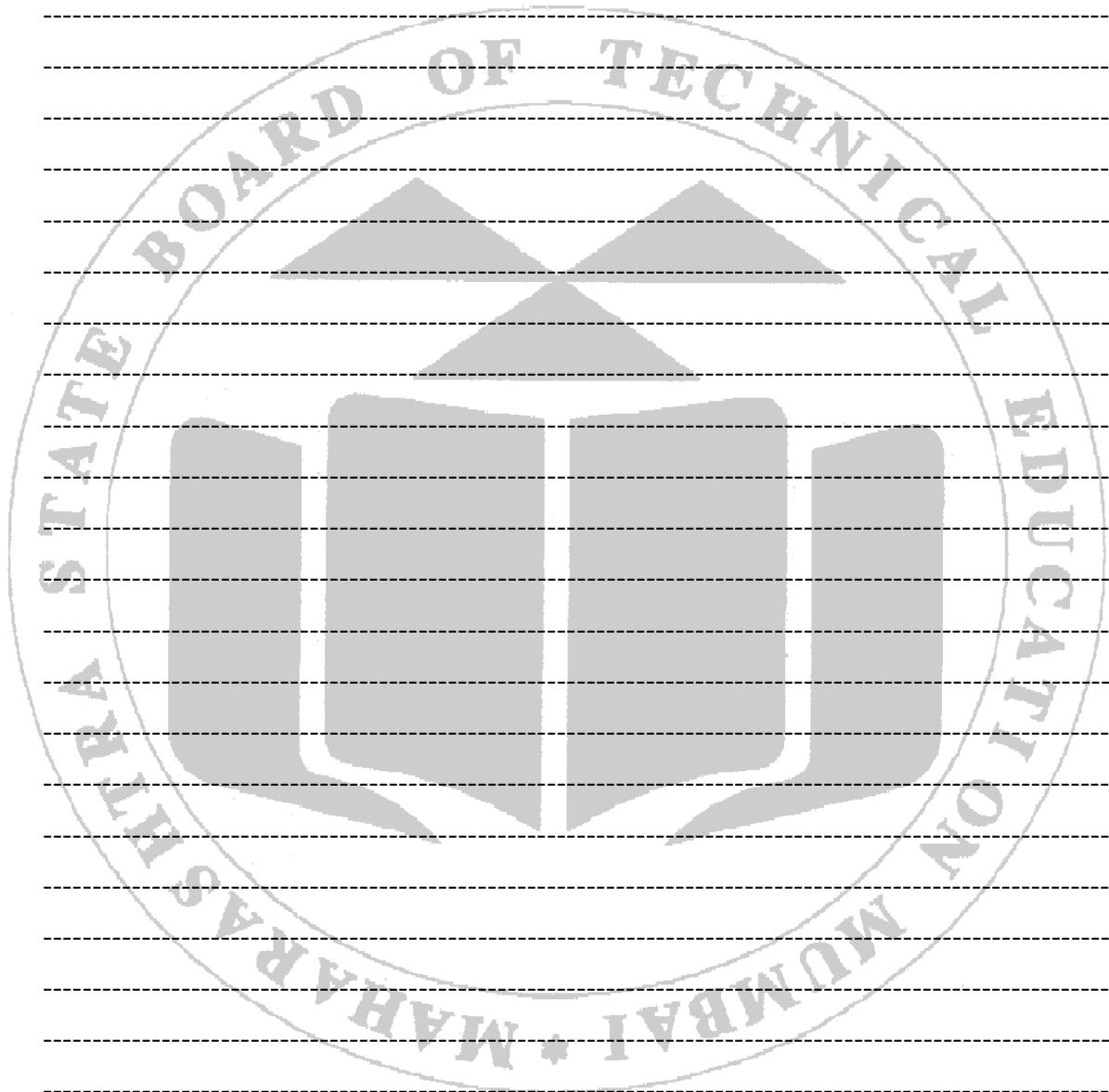

XVI. References / Suggestions for Further Reading

- <https://www.youtube.com/watch?v=wLRptWkhlyY>
- https://www.youtube.com/watch?v=lwA_TGnJyUI
- <https://www.youtube.com/watch?v=6SbwBiN5Yis>
- <https://www.youtube.com/watch?v=XQq5xCmXRyA>
- <https://www.youtube.com/watch?v=xMn6HqrTVI8>

XVII . Rubrics for Assessment Scheme

Performance indicators		Weightage
Process related (10 Marks)		40%
1	Preparation of experimental set up	10%
2	Mounting of tapes	10%
3	Testing of tapes	20%
Product related (15 Marks)		60%
4	Prepared tape specimen	30%
5	Interpretation of result	10%
6	Conclusions	10%
7	Practical related questions	10%
Total (25Marks)		100%

Marks Obtained			Dated signature of Teacher
Process Related(10)	Product Related(15)	Total (25)	

Practical No. 11: Adhesive strength determination of scotch tape, electrical tape and masking tape using relevant peel testers

I. Practical Significance

Adhesives are all around us. They come in the form of tapes, wall/window/floor decals, and glues. The strength of these adhesives determines their use. Stronger adhesives such as duct tape leave a residue and are very difficult to remove from most surfaces. Weaker adhesives such as wall decals must be strong enough to stay on the wall but must be able to be easily removed. The strength of these adhesives is measured by doing a peel test. A peel test measures the force required to remove the adhesive from the surface.

II. Industry/Employer Expected Outcome (s)

This practical is expected to develop the following skills for the industry/Employer

1. Gaining hands-on experience with peel testers, understanding their components, and learning to operate them effectively.
2. Understanding the basic principles of material science related to adhesives
3. Evaluating the quality and performance of tape products, which is important for quality control in manufacturing and product development.

III. Course Level Learning Outcome (CO)

CO3- Select relevant non ferrous & powder material components for the engineering application

IV. Laboratory Learning Outcome(s)

- Use relevant peel tester
- Determine the adhesive strength of scotch tape, electrical tape and masking tape on a smooth surface.

V. Relative Affective Domain related Outcome(s)-

- Follow safe practices
- Practice good housekeeping
- Demonstrate working as a leader/a team member
- Maintain tools and equipment
- Follow ethical practices

VI. Minimum Theoretical Background with diagram (if required)

Peel adhesion is defined as the force needed to "peel" an adhesive tape from any given surface, whether flexible, smooth, or rigid. This "peel" force is always and only measured across the width of the taped substrate, making it the more difficult separating force to resist. It is important to understand the peel adhesion factor, as it can serve as a guide for choosing the right tape for the application. Some of the common types of tapes are cellophane tape, duct tape, scotch tape, electrical tape and masking tape.

Duct tape is one of the most versatile tapes and they can be used for many applications like holding carpets in place, repairing hoses, binding books and even holding together parts of a broken window. They are normally used in places where long-lasting, flexible and strong adhesive is required.

Electrical tape is normally used in homes or automobiles to insulate electrical wiring. In homes, they are normally used for installing electrical fixtures such as lights and fans. Their purpose is to insulate wire joints and terminate exposed live wires to prevent short circuits or electrocution in case someone accidentally touches the exposed wire.

VII. Experimental setup (Model)-

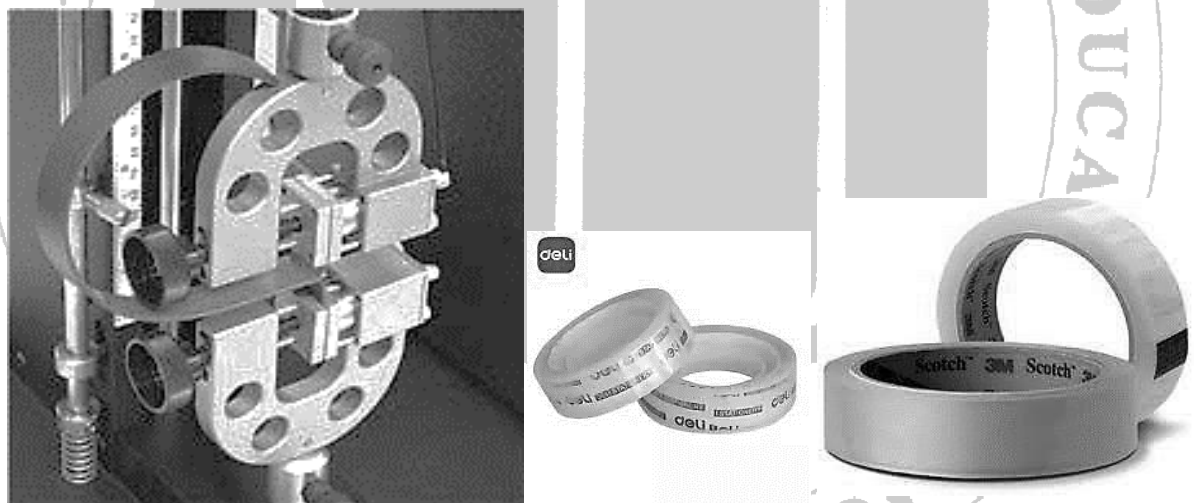

Fig.11.1. Peel Tester

VIII. Required Resources /Apparatus/Equipment with specification

Sr.No	Name of Resources	Suggested broad specification	Quantity
1	Digital Peel Tester	Load capacity: Up to 50 kg No. of load cell: One Cross Travel: Up to 250 mm Speed: 300 mm/minute Direct display: Peak load Paint: Powder coated Power: 230 Volts, 50 Hz, single phase	1
2	Peeling Strength Tester	Capacity Range 0~200 N (30 N, 50 N and 100 N are optional) Accuracy 1% of reading value Resolution 0.01N Test Speed 50,100,150,200,250,300,500 mm/min Specimen Width :S30 mm Stroke 500mm	1
3	Electric Tape	0.18mm thickness, Plasticized PVC backing, Rubber based adhesive	1 reel
4	Masking Tape	Backing - Crape paper Thickness- 0,14 mm Adhesive -rubber	1
5	Masking Tape	Backing - Polyester film Thickness- 0.06 mm Adhesive - Silicon	1

IX. Precautions to be Followed

- Ensure the surface to which the tape will be adhered is clean, dry, and free of contaminants such as dust, oil, or grease. Use a solvent like isopropyl alcohol to clean the surface.
- Cut the tape samples to a consistent length and width. This ensures uniformity in testing and comparability of results.
- Allow a consistent amount of time for the tape to adhere to the surface before testing. This can be standardized based on the specific adhesive properties of the tapes.
- Ensure the peel tester is properly calibrated according to the manufacturer's instructions. Regular calibration checks are essential to maintain accuracy.
- Perform tests in a controlled environment where temperature and humidity are kept constant, as these factors can affect adhesive properties.
- Ensure the testing area is free from drafts and vibrations that could affect the stability of the peel test.
- If cutting is required during sample preparation, handle cutting tools and blades with care to avoid injury.

- Use peel tester carefully
- Apply tapes on test plate properly

X. Procedure

1. Use a solvent like isopropyl alcohol to thoroughly clean the substrate. Wipe it with a lint-free cloth to ensure it is free of contaminants such as dust, oil, or grease.
2. Cut the tape into uniform strips of a consistent length and width, typically 1 inch (25.4 mm) wide and at least 6 inches (150 mm) long.
3. Label each tape sample with an identifier to keep track of different tests
4. Place the tape onto the clean substrate. Use a roller or squeegee to apply even pressure across the tape, ensuring full contact with the substrate and eliminating air bubbles.
5. Allow the tape to adhere to the substrate for a consistent amount of time before testing. A standard waiting time might be 15 minutes to 24 hours, depending on the adhesive properties and the testing standards you are following.
6. Ensure the peel tester is calibrated according to the manufacturer's instructions.
7. Secure the substrate with the adhered tape in the peel tester's clamp. Ensure it is properly aligned and firmly held in place.
8. Peel back a small section of the tape (about 1 inch) from the substrate. Attach this free end to the peel tester's upper clamp.
9. Set the peel angle to the desired degree, typically 90 degrees or 180 degrees.
10. Set the peel speed to the standard rate, often 300 mm/min (12 in/min), but this can vary depending on the standard being followed.
11. Begin the peel test. The peel tester will pull the tape from the substrate at the set speed and angle, measuring the force required to peel the tape.
12. The peel tester will generate a force vs. distance or force vs. time curve. Record the peak force and the average peel strength.
13. Record the average force required for peeling.
14. Examine the peeled tape and substrate for any anomalies such as adhesive residue on the substrate or incomplete peeling.
15. Clean the peel tester and substrate to remove any adhesive residue before the next test.
16. Perform multiple tests (at least three replicates) for each type of tape to ensure repeatability and accuracy of the results.
17. Calculate the average peel strength from the multiple tests conducted. This can be done by averaging the peak forces or using the area under the force vs. distance curve.

XI. Observations and calculations

Name of tape	Load (N)	Thickness (t) mm	Width (b) mm	Avg. Peel Strength N/mm ²
Scotch tape				
Electrical tape				
Masking tape				

Peel Strength = Load/ Area under Load

XII. Results

1. Adhesive strength of Scotch tape is -----
2. Adhesive strength of Electrical tape is ----
3. Adhesive strength of Masking tape---

XIII. Interpretation of Results

.....

.....

.....

.....

XVII. References / Suggestions for Further Reading

- <https://www.youtube.com/watch?v=6XyrePiyreQ>
- <https://www.youtube.com/watch?v=IlSWCqNnE7c>

XVII Rubrics for Assessment Scheme

Performance indicators		Weightage
Process related (10 Marks)		40%
1	Preparation of experimental set up	10%
2	Mounting of tapes	10%
3	Testing of tapes	20%
Product related (15 Marks)		60%
4	Prepared tape specimen	30%
5	Interpretation of result	10%
6	Conclusions	10%
7	Practical related questions	10%
Total (25Marks)		100%

Marks Obtained			Dated signature of Teacher
Process Related(15)	Product Related(10)	Total (25)	

Practical No. 12: Identification of different types of plastics using flame tests.

I. Practical Significance

When working with plastics there is often a need to identify which particular plastic material has been used for a given product. This is essential to get an idea of the cost and likely properties of the product. Identifying different types of plastics using flame tests lies in their utility across multiple fields. This method aids in efficient recycling, ensures quality control in manufacturing, supports forensic investigations, serves as an educational tool, and facilitates research. Despite its limitations and safety concerns, the flame test remains a valuable and practical tool for the preliminary identification of plastics.

II. Industry/Employer Expected Outcome (s)

This practical is expected to develop the following skills for the industry/Employer.

1. Use relevant mechanical engineering materials in different applications
2. Use of flame test setup
3. Observation skill

III. Course Level Learning Outcome (CO)

CO3. - Select relevant non ferrous and powder material components for the engineering application.

IV. Laboratory Learning Outcome(s)

- Perform flame test to identify different types of plastics.
- Identify properties of materials

V. Relative Affective Domain related Outcome(s)-

- Follow safety practices.
- Practice good housekeeping.
- Demonstrate working as a leader/a team member.
- Maintain tools and equipment.
- Follow ethical Practices.

VI. Minimum Theoretical Background

A polymer is the basic long chain molecule and is a pure molecule. Polymers are most often modified or compounded with additives (including colours) to form useful materials. The compounded product is generally termed as plastic.

The polymer based materials are classified as "Thermoplastic materials" and "Thermosetting materials". Thermoplastic materials can be melted many times and

will harden on cooling to return to their normal state. Applying heat will soften them again. Thermosetting materials can be shaped and hardened once only. Applying heat will not soften the material but will burn or char it.

VII. Experimental setup (Model)-

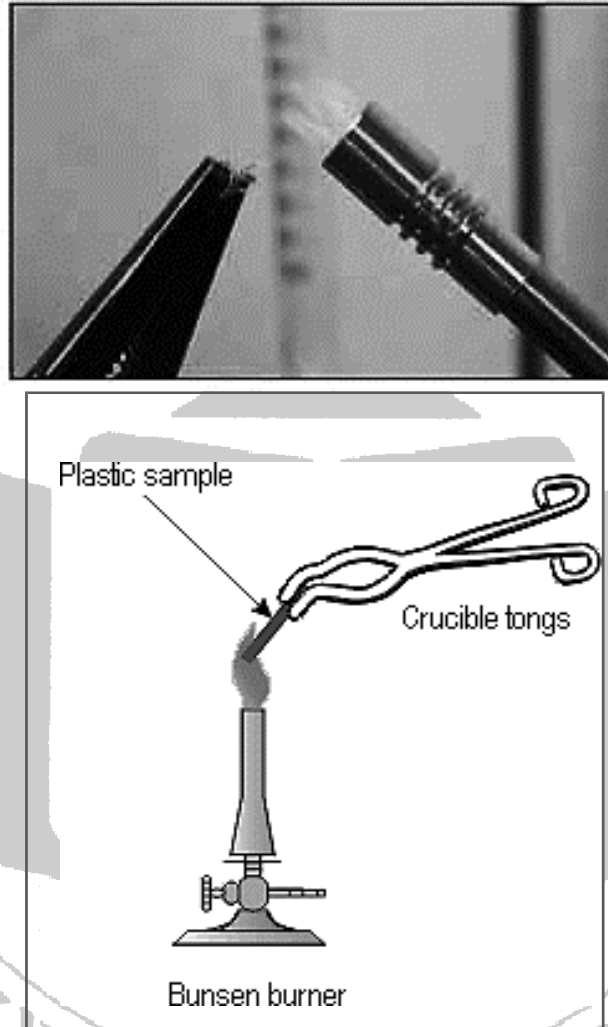

Fig.12.1 Flame test

VIII. Required Resources /Apparatus/Equipment with specification

Sr.No	Instruments/Components	Specifications	Quantity	Remark
1	Given specimen of plastics	1 to 2cm strip of each sample	1 in group of 5 students	
2	Tong,Bunsen Burner , Beakers	As per availability	1	

IX. Precautions to be Followed

1. Flame testing should be performed within a well-ventilated hood.
2. Arrangement of water near the site of test should be made.

X. Procedure

1. Take different samples of plastics and label them A,B,C.
2. Take sample A and clamp it in the tong.
3. Place the sample on burner flame.
4. Observe the burning of sample.
5. Note the whether samples are being softened or decomposed.
6. Repeat the procedure with other samples.
7. Record the observations.

XI. Observations -**Table 12.1: Identification of Flame color and Type of polymer**

Sr. No.	Polymer Specimen	Flame Color	Type of polymer	Remarks
1	A			
2	B			
3	C			
4	D			
5	E			

XII.Results

1. Different color of flames
2. Knowing the unknown samples

XIII. Interpretation of Results

.....

.....

.....

.....

.....

XIV. Conclusions

.....

.....

.....

XV. Practical Related Questions

Note: Below given are few sample questions for reference. Teachers must design more such questions so as to ensure the achievement of identified CO.

- 1 State the major sources of raw materials for the manufacture of plastics.
- 2 State the different tests other than flame test for identification of plastics.
- 3 Explain which plastics are harmless to environment.
- 4 List the major characteristics of plastics.
- 5 Explain the different methods to recycle the plastics.
- 6 Define thermoplastic and thermosetting plastic material.

[Space for Answer]

.....

.....

.....

.....

.....

.....

.....

.....

.....

.....

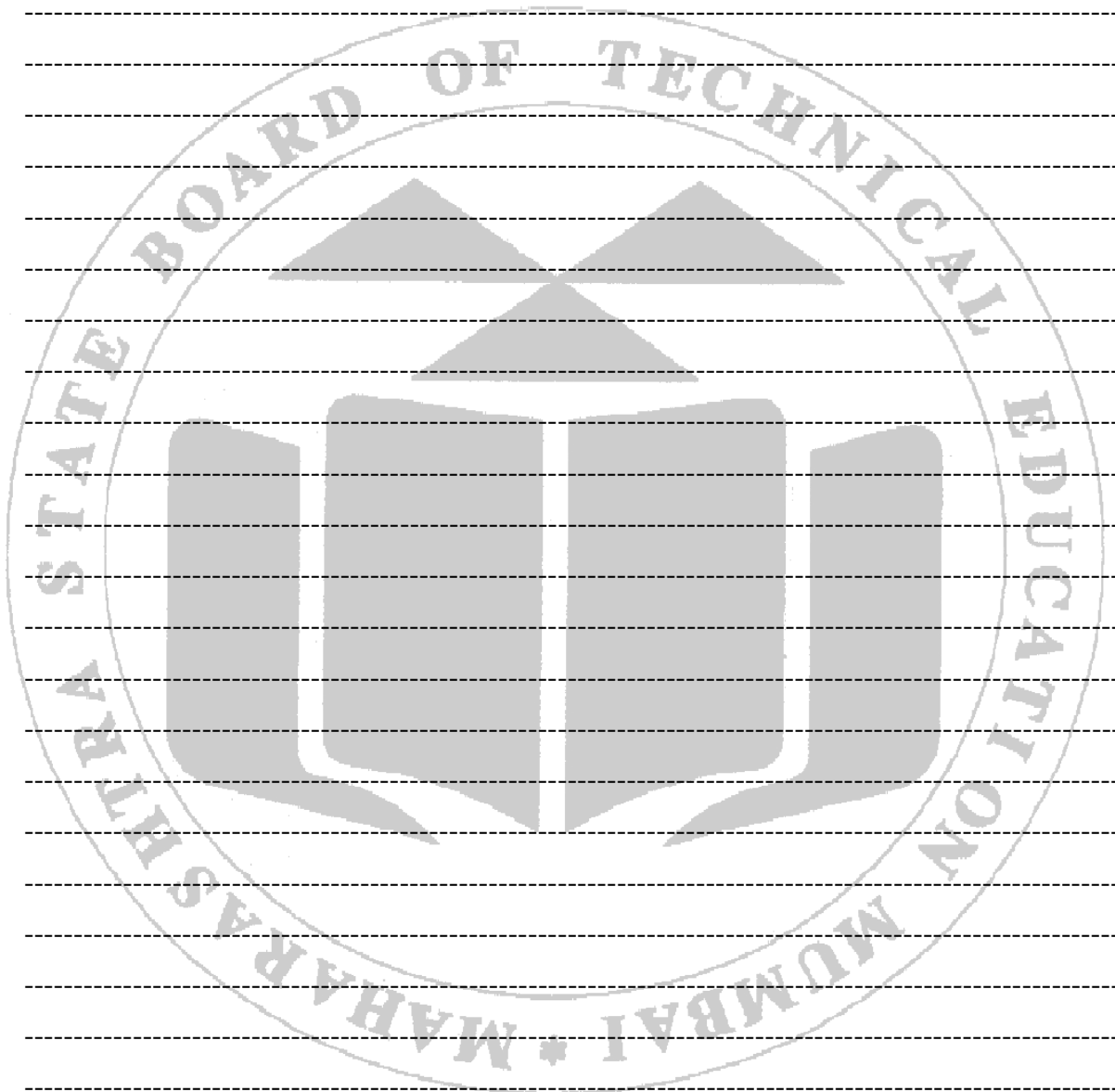

XVI. References / Suggestions for Further Reading

- <https://www.youtube.com/watch?v=asHNidtj6dc>
- https://www.youtube.com/watch?v=_jYs-kv2tVY
- <https://www.youtube.com/watch?v=3fNujTRvpDI>
- <https://www.youtube.com/watch?v=4EEwldmZg8g>
- <https://www.youtube.com/watch?v=M4DIGSgRka8>
- <https://www.youtube.com/watch?v=IYmLy5IOhDQ>

XVII Rubrics for Assessment Scheme

Performance Indicators		Weightage
Process Related (15Marks)		60%
1	Preparation of experimental set up	20%
2	Burning of plastic specimen	20%
3	Observation of flame	20%
Product Related (10Marks)		40%
4	Prepared specimen	10%
5	Interpretation of result	10%
6	Conclusions	10%
7	Practical related questions	10%
Total (25Marks)		100%

Marks Obtained			Dated signature of Teacher
Process Related(15)	Product Related(10)	Total (25)	

Practical No. 13: Identification of behavior of the shape-memory alloy as a function with regards to temperature using High-temperature oven or electrical current.

I. Practical Significance

Shape memory alloys (SMAs) are the special materials that have the ability to return to a predetermined shape when heated. When this alloy is in below transformation temperature it undergoes low yield strength and will deform easily into any new shape which it will retain, if this alloy is heated above its transformation temperature it changes its crystal lattice structure which returns to its real shape. Identifying the behavior of SMAs as a function of temperature is practically significant for optimizing material performance, ensuring reliability and safety, enhancing energy efficiency, and enabling innovative applications across various industries.

II. Industry/Employer Expected Outcome (s)

This practical is expected to develop the following skills for the industry/Employer

1. Use relevant mechanical engineering materials in different applications.
2. Identification of shape memory effect.

III. Course Level Learning Outcome (CO)

CO4- Select relevant non metallic and Advanced material for the engineering application.

IV. Laboratory Learning Outcome(s)

- Use a High-temperature oven or electrical current.
- Identify behavior of the shape-memory alloy .

V. Relative Affective Domain related Outcome(s)-

- Follow safety practices.
- Practice good housekeeping
- Demonstrate working as a leader/a team member.
- Maintain tools and equipment.
- Follow ethical Practices

VI. Minimum Theoretical Background

"Shape Memory" describes the effect of restoring the original shape of a plastically deformed sample by heating it. Shape memory effect is one of the unique properties which a part returns to the actual shape during heating, after being deformed. In other words it is the ability of the material to regain from after plastic deformation by thermal processing .SMAs undergo phase transformations between martensite and austenite phases, which are temperature-dependent. Accurate identification of these transformations is essential for optimizing the material's performance in applications such as actuators, sensors, and medical devices. Common SMAs such as Nickel-Titanium (NiTi), Copper-based alloys (Cu-Al-Ni), and Iron-based alloys (Fe-Mn-Si). Knowledge of the martensite and austenite phases, which are critical for the shape-memory effect and superelasticity. Understanding how temperature influences the phase transformation. Defects like dislocations and grain boundaries influence the behavior of SMAs during phase transformations. Understanding the principles of Joule heating, where electrical current passing through a resistive material generates heat.

VII. Experimental setup (Model)-

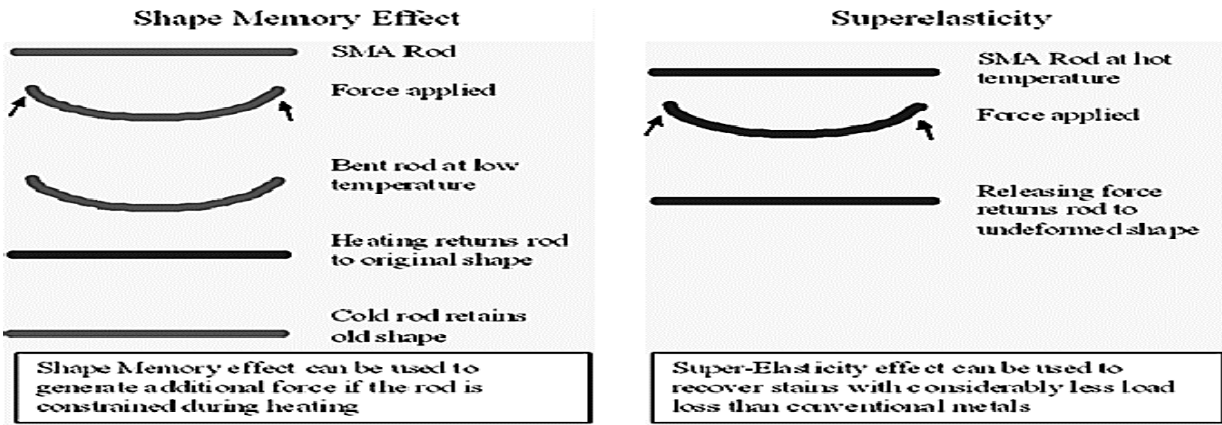

Fig.13.1 Shape Memory Effect Mechanism

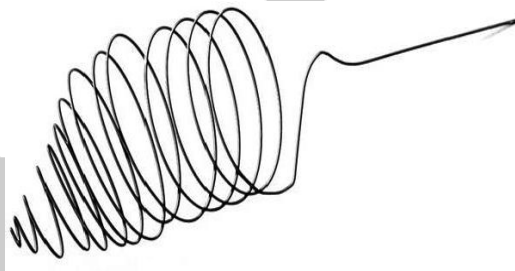

Fig.13.2 Example of shape memory

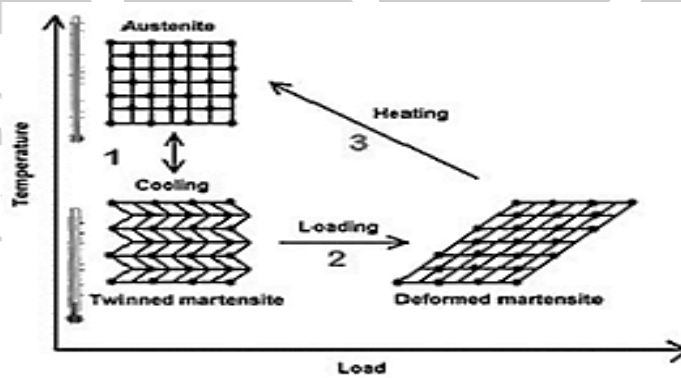

Fig.13.3 Shape Memory Effect Mechanism

VIII. Required Resources /Apparatus/Equipment with specification

S. No.	Name of Resource	Suggested Broad Specification	Quantity
1	Shape memory alloy wire	Minimum 10 mm of nitinol wire of available diameter.	5
2	Glass beaker	Suitable Size	2
3	Heat Source (High temperature oven or electrical current)	A power source capable of capable of at least 10 Amperes and 10 Volts will be necessary.	2
4	High temperature gloves/tong	Suitable type	Each 2

IX. Precautions to be Followed

- Use protective equipment such as tongs or high temperature gloves when handling hot items, and beware of electric shock.

X. Procedure

1. Fill the beaker with water.
2. Place the beaker on the hot plate and tum to 'High'. The water should be heated to just below boiling.
3. Bend the nitinol wire to a desired shape.
4. Place the nitinol wire in the hot water.
5. The nitinol wire should immediately return to its original shape
6. Remove the nitinol wire from the beaker using the pliers and show it to the students.
7. Repeat steps 3-6, trying different shapes and amounts of deformation.
8. Repeat steps 3-6 with the steel wire.

XI. Observations

XII. Results

1. Heated wire-
2. Cooled wire-

XIII. Interpretation of Results

XIV. Conclusions and Recommendation

XV. Practical Related Questions

Note: Below given are few sample questions for reference. Teachers must design more such questions so as to ensure the achievement of identified CO.

1. State the difference between shape memory and super elasticity on a macroscopic level and on a microscopic level.
2. Justify, the nitinol wire change shape, but not the steel wire.
3. Explain the difference in super-elasticity and the shape memory effect. How are both achieved?
4. State the forms of SMA have the same physical appearance.
5. State Practical applications for shape memory alloys.
6. Explain the effect when a metal is heated above its transformation temperature. How can this effect are reversed.
7. State the effect of the structure of a SMA during transition.

[Space for Answer]

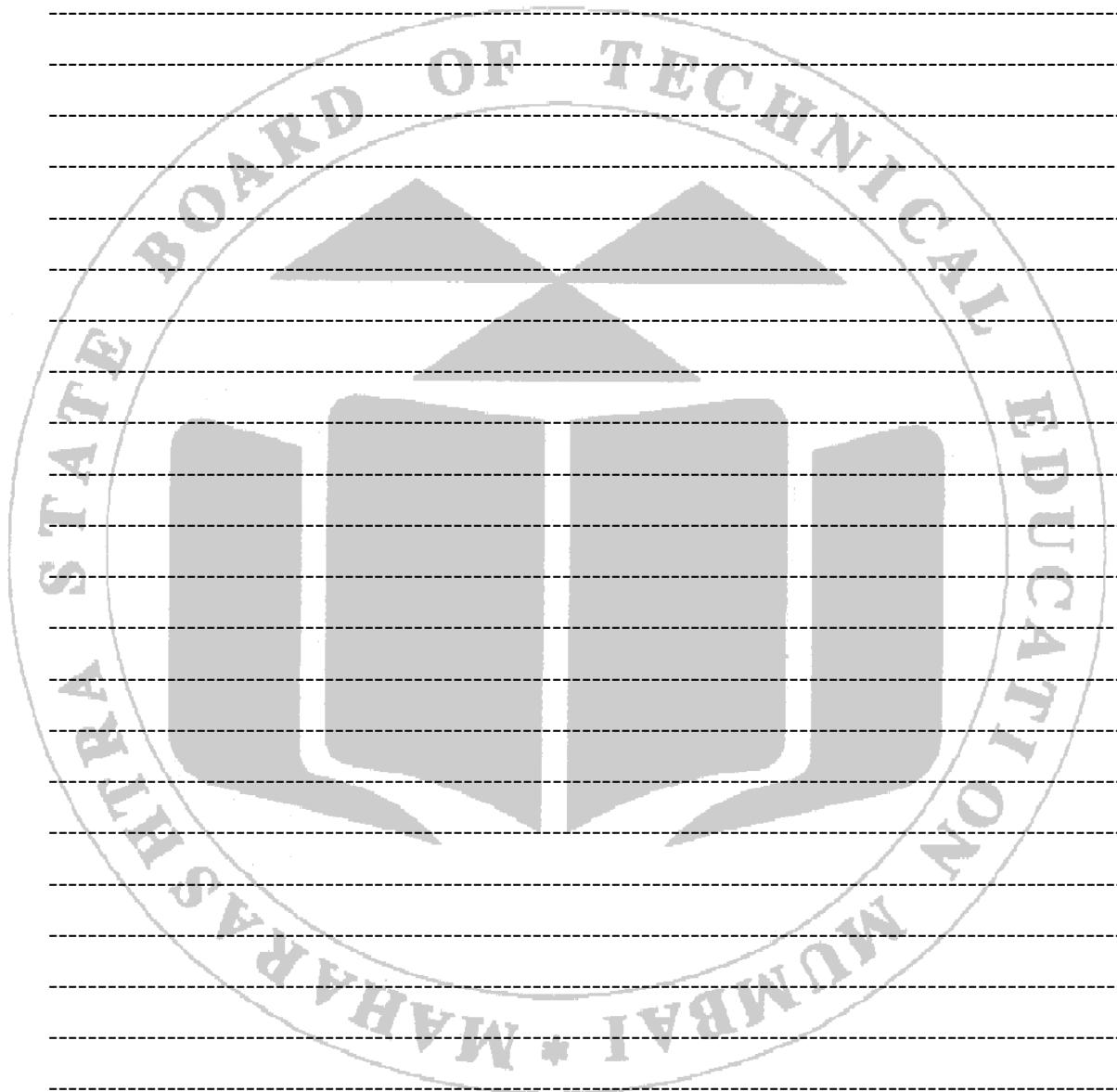

XVI. References / Suggestions for Further Reading

- <https://www.youtube.com/watch?v=xhykVMFDULk>
- <https://youtu.be/AwMldOsWsoo?t=77>
- <https://www.youtube.com/watch?v=QYp9rIIRM8s>
- <https://www.youtube.com/watch?v=4Yi4epJ83EE>
- <https://www.youtube.com/watch?v=lrrPv5AIVXg>
- <https://www.youtube.com/watch?v=wKoc7-APFsk>
- <https://www.youtube.com/watch?v=fsBHFj2FJ4>

XVII Rubrics for Assessment Scheme

Performance Indicators		Weightage
Process Related (15Marks)		60%
1	Preparation of experimental set up	15%
2	Observe the shape before Heating the specimen wire	15%
3	Observe the shape during Heating	15%
4	Observe the shape after Cooing the specimen wire	15%
Product Related (10Marks)		40%
5	Hot and cooled wire	10%
6	Interpretation of result	10%
7	Conclusions	10%
8	Practical related questions	10%
Total (25Marks)		100%

Marks Obtained			Dated signature of Teacher
Process Related(15)	Product Related(10)	Total (25)	

Practical No. 14: Comparison of hardness of mild steel using quenching mediums like oil, water & brine in a muffle /box type furnace.

I. Practical Significance

Hardening is the commonly used heat treatment process to obtain desired hardness and structure. It involves heating the steel above transformation temperature, holding at that temperature and quenching it immediately in a suitable cold medium such as water, brine solution, oil, molten salt and air. The rapidity with which heat is removed by the quenching medium governs the hardness obtained and distortion of steel. Therefore selection of proper quenching medium is important to obtain desired results. It enhances our understanding of heat treatment effects, optimizes mechanical properties, supports industry-specific applications, and promotes environmental and safety considerations. Additionally, it holds educational value for training future metallurgists and engineers, fostering innovation, and contributing to research and development in material science. Through such practical comparisons, industries can achieve better product performance, cost efficiency, and sustainable practices.

II. Industry/Employer Expected Outcome (s)

This practical is expected to develop the following skills for the industry/Employer.

1. Use relevant mechanical engineering materials in different application.
2. Use of Muffle/ Box furnace.
3. Select suitable quenching medium for the desired results.
4. Use of Rockwell hardness testing machine

III. Course Level Learning Outcome (CO)

CO1- Select suitable material(s) based on desired properties according to application.

CO5- Use relevant heat treatment processes in given situations.

IV. Laboratory Learning Outcome(s)

- Use a muffle /box type furnace
- Use various quenching mediums for mild steel.
- Compare the hardness of mild steel.

V. Relative Affective Domain Related Outcome(s)-

- Follow safety practices.
- Practice good housekeeping.
- Demonstrate working as a leader/a team member.
- Maintain tools and equipment.
- Follow ethical Practices.

VI. Minimum Theoretical Background

Plain carbon steels are widely used for many industrial applications and manufacturing on account of their low cost and easy fabrication. They are classified on the basis of their carbon content as their major alloying element is carbon. Hardness and other mechanical properties of plain carbon steels increase with the rise in concentration of carbon dissolved in austenite prior to quenching during hardening heat treatment, which may be due to transformation of austenite into martensite.

Therefore, the mechanical strength of medium carbon steels can be improved by quenching in appropriate medium. Comparisons of different quenchants in the heat-treatment processes of steels are of great usefulness in order to achieve desired hardness, strength or toughness, and to minimize the possibility of the occurrence of quench cracks due to the evolution of residual stresses. The choice of effective quenching medium following heat treatment is critical to ensuring the achievement of the desired mechanical properties; hence, the selection of a quenchant depends on the quench sensitivity of a particular grade of steel and on the severity of the quench medium. Provides a foundation for understanding the principles behind heat treatment and quenching of mild steel using different mediums. By exploring the effects of oil, water, and brine on the hardness and microstructure of mild steel, one can optimize the heat treatment process for desired material properties while mitigating risks such as distortion and cracking. This knowledge is essential for practical applications in various industries where steel performance is critical. Mild steel, also known as low-carbon steel, typically contains 0.05% to 0.25% carbon by weight. It may also contain small amounts of manganese, silicon, and other alloying elements. Mild steel is known for its good ductility, weldability, and toughness. However, it has relatively low hardness compared to high-carbon steels. Commonly used in construction, automotive, and machinery due to its versatility and cost-effectiveness. Oil quenching provides moderate cooling rates and results in a balance between hardness and toughness. It is less likely to cause distortion or cracking compared to water. Used when a controlled cooling rate is required to avoid excessive brittleness Water quenching offers a faster cooling rate than oil, leading to higher hardness. However, it increases the risk of distortion and cracking due to thermal shock. Suitable for steels that can withstand rapid cooling without cracking, typically used for achieving high hardness.

VII. Experimental setup (Model)-

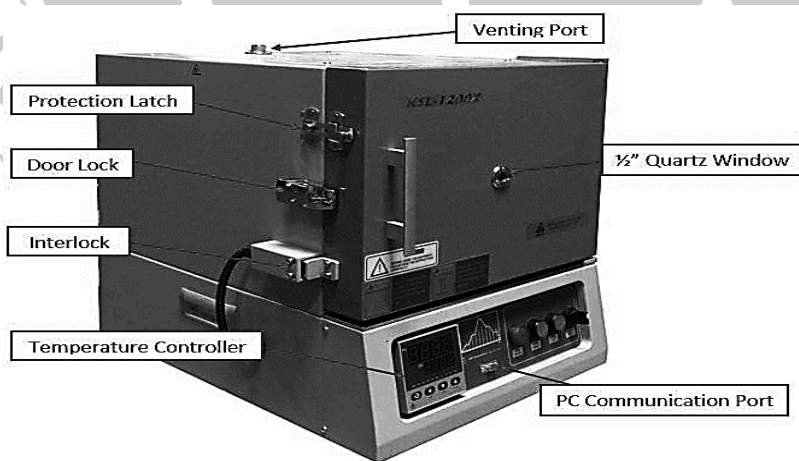

Fig14.1 Box Furnace

VIII. Required Resources /Apparatus/Equipment with specification

Sr. No.	Instrument /Components	Specification	Quantity
1	Laboratory box furnaces	1200°C	02
2	Digital Rockwell Hardness tester- Easy-to-use Electronics Console	Hi/Lo Tolerance Settings, Adjustable Time @ Load Average Test Group Results 2-9; Test Result Memory Capacity 5000 results, RS232 Output,- Average Range	02

IX. Precautions to be Followed

- Always wear appropriate PPE, including heat-resistant gloves, lab coats, safety goggles, and face shields to protect against burns and splashes from hot materials and quenching liquids.
- Ensure the laboratory is well-ventilated to prevent the buildup of fumes from quenching oils or other hazardous vapors.
- Keep a fire extinguisher and first aid kit readily accessible. Familiarize yourself with the location and use of these safety tools.
- Use tongs or other heat-resistant tools to handle hot samples to avoid burns and thermal shock.
- Ensure all samples are of uniform size and shape to maintain consistency in heating and cooling.
- Clean samples thoroughly to remove any contaminants that could affect the heat treatment process
- For quenching, the sample should be immediately transferred from the furnace to the water/oil bath.
- For brine quenching, ensure the correct concentration of salt in the water.
- Be cautious of the potential for violent reactions, especially with water and brine, which can cause steam explosions.
- The quenching media should be agitated.
- The specimen should be well grinded and polished before measuring hardness.
- Hardness should be checked in cold state

X. Procedure

1. Prepare alloy steel samples of uniform size and shape to ensure consistent heating and quenching
2. Clean the samples to remove any surface contaminants.
3. Prepare three separate containers for oil, water, and brine quenching.
4. Ensure the brine solution has an appropriate salt concentration (e.g., 10% salt by weight).
5. Ensure each container has sufficient volume to fully submerge the samples.
6. Place the cleaned alloy steel samples into the furnace, ensuring they are evenly spaced and centrally located to ensure uniform heating.
7. Allow the samples to soak at the austenitizing temperature for the required time (e.g., 30-60 minutes) to achieve a homogeneous austenitic phase.
8. Remove one sample from the furnace using tongs or heat-resistant tools and immediately transfer it to the first quenching medium (e.g., oil). Ensure the sample is fully submerged.
9. Agitate the quenching medium gently to avoid vapor pockets and ensure uniform cooling.

10. Repeat the process for the remaining samples, quenching one in water and one in brine.
11. Select any two cooling medium for quenching.
12. Take out the samples one by one and immerse it in quenching mediums.
13. As sample gets cooled, its faces are ground and polished to get an even surface.
14. Perform hardness tests on each sample using a Rockwell hardness tester, following the standard procedure for the selected scale (e.g., Rockwell C).Alternatively, use Brinell if preferred.
15. Take multiple hardness measurements at different locations on each sample to ensure accuracy and repeatability.
16. Record the hardness values for each sample
17. Calculate the average hardness value for each sample.
18. Compare the hardness values to determine the effect of each quenching medium.
19. Check hardness and plot graph, if desired

Selection of heat treatment conditions

Heating temperature	Soaking time	Quenching media
880°C,920°C,960°C	1 hour	Water, Brine, Oil or Air

**XI. Observations and calculations –
Brinell Hardness Number Before Quenching**

Sr. No	Specimen	Indenter Diameter(D) in mm	Total load(P) Kg-F	Diameter of Indentation(d) in mm			Average Dia.	BHN
				1	2	3		
1	Specimen-1							
2	Specimen-2							
3	Specimen-3							

Rockwell Hardness Number Before Quenching

SR. No	Specimen	Type of Indenter	Rockwell Hardness Number(RHN)			Avg. RHN
			1	2	3	
1	Specimen -4					
2	Specimen -5					
3	Specimen-6					

Measurement of Effect of Quenching on Hardness by Brinell Hardness Tester

Sr. No.	Material	Initial Hardness (BHN)	Hardness after quenching		
			Quenching Medium		
			Water	Brine	Oil
1	Specimen-1				
2	Specimen-2				
3	Specimen-3				

Measurement of Effect of Quenching on Hardness by Rockwell Hardness Tester

Sr. No.	Material	Initial Hardness (RHN)	Hardness after quenching		
			Quenching Medium		
			Water	Brine	Oil
1	Specimen -4				
2	Specimen -5				
3	Specimen-6				

Calculations:

Calculate Hardness Before quenching treatment:

Calculate Hardness After quenching treatment:

XII. Results

XIII. Interpretation of Results

XIV. Conclusions and Recommendation

XV. Practical Related Questions

Note: Below given are few sample questions for reference. Teachers must design more such questions so as to ensure the achievement of identified CO.

1. State the importance of cooling rate.
2. Explain the relationship between heat treatment and the resulting hardness values obtained in this experiment.
3. State the effect of water contamination affect the performance of quench oil.
4. State the reason for stresses develops during quenching.
5. Explain expected cooling rates for each quenching medium, and how can they be measured or calculated.

6. Besides hardness, what other mechanical properties (e.g., toughness, tensile strength) might be affected by the quenching process, and how can these be evaluated.
7. Explain quenching medium produces the most desirable combination of hardness and ductility for industrial applications of mild steel.
8. Explain environmental impacts are associated with each quenching medium, and how can they be mitigated
9. List the specific parameters for the heat treatment process in the muffle/box-type furnace (e.g., temperature, heating time, cooling rate).

[Space for Answer]

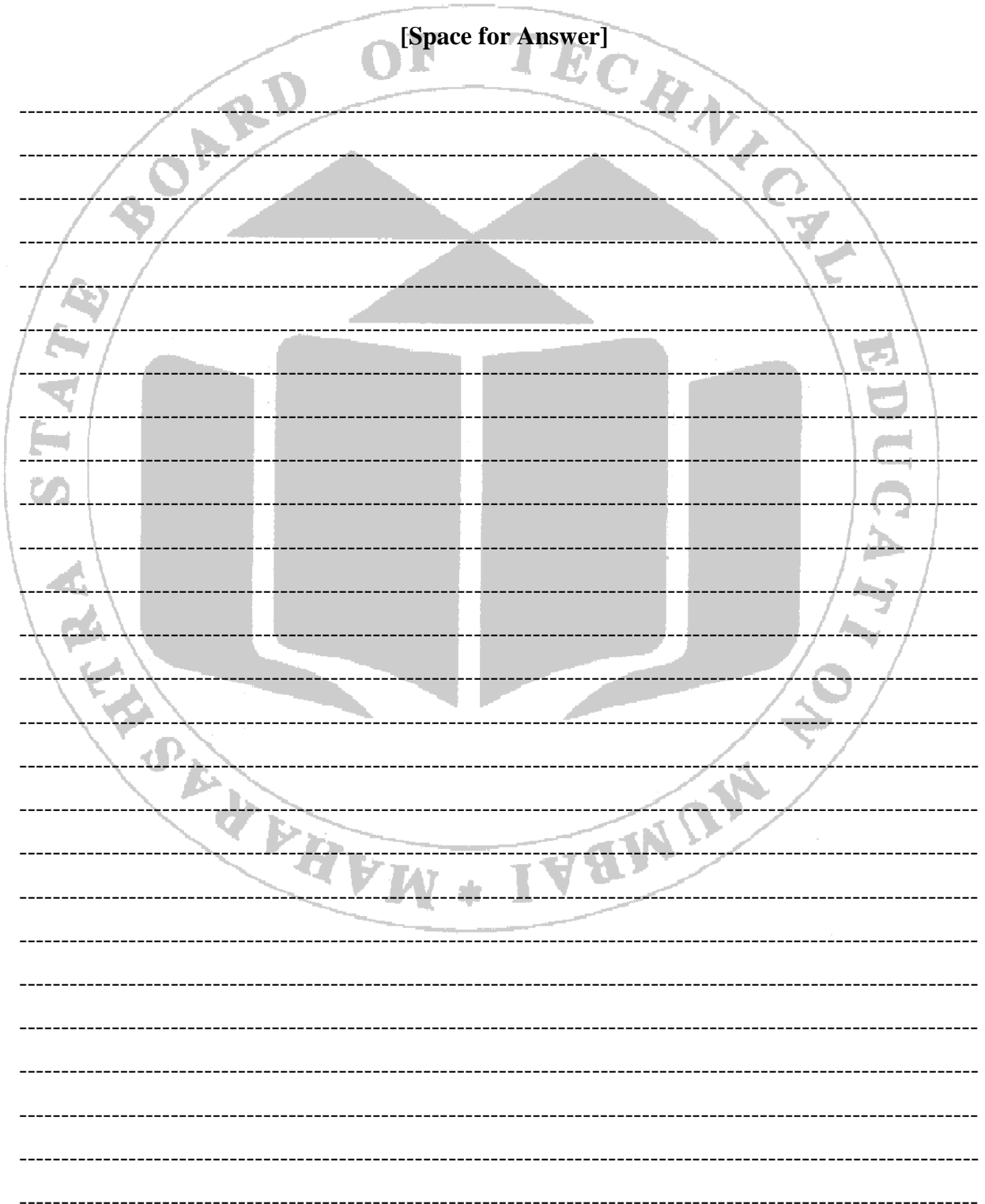

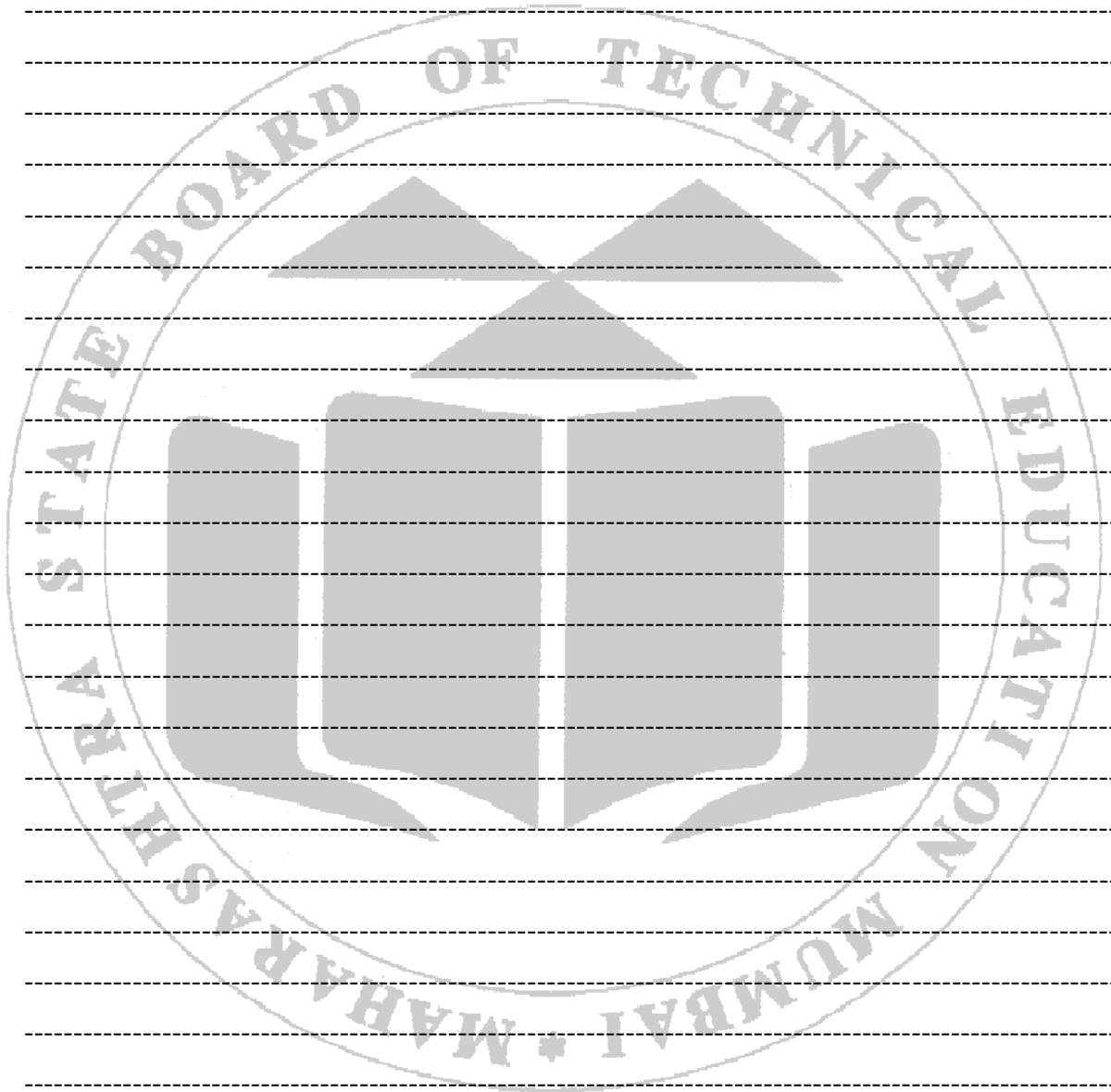

XVI. References / Suggestions for Further Reading

- <https://www.wikihow.com/Harden-Steel>
- <https://www.youtube.com/watch?v=QQ051Zie8pk>
- https://www.youtube.com/watch?v=Gmqkuc-n_IU
- <https://www.youtube.com/watch?v=UlpavVgm8CO>
- <https://www.youtube.com/watch?v=U-DesKKNi9g>
- <https://www.youtube.com/watch?v=hw4RIOuG7ok>
- <https://www.youtube.com/watch?v=gPKkgmDoEoU>
- <https://www.youtube.com/watch?v=bkxVLI3ezwA>

XVII Rubrics for Assessment Scheme

Performance indicators		Weightage
Process related (15 Marks)		60%
1	Hardening of specimen	20
2	Quenching of specimen	20
3	Hardness measurement of specimen	20
Product related (10 Marks)		40%
4	Hardened specimen	20
5	Quenched specimen	20
Total (25Marks)		100%

Marks Obtained			Dated signature of Teacher
Process Related(15)	Product Related(10)	Total (25)	

Practical No. 15: Comparison of hardness of alloy steel using quenching mediums like oil, water & brine in a muffle /box type furnace.

I. Practical Significance

Hardening is the commonly used heat treatment process to obtain desired hardness and structure. It involves heating the steel above transformation temperature, holding at that temperature and quenching it immediately in a suitable cold medium such as water, brine solution, oil, molten salt and air. The rapidity with which heat is removed by the quenching medium governs the hardness obtained and distortion of steel. Therefore selection of proper quenching medium is important to obtain desired results.

II. Industry/Employer Expected Outcome (s)

This practical is expected to develop the following skills for the industry/Employer.

- Use relevant mechanical engineering materials in different application.
- Use of Muffle/ Box furnace.
- Select suitable quenching medium for the desired results.
- Use of Rockwell hardness testing machine

III. Course Level Learning Outcome (CO)

CO1- Select suitable material(s) based on desired properties according to application.

CO5- Use relevant heat treatment processes in given situations.

IV. Laboratory Learning Outcome(s)

- Use a muffle /box type furnace
- Use various quenching mediums for mild steel.
- Compare the hardness of mild steel.

V. Relative Affective Domain Related Outcome(s)-

- Follow safety practices.
- Practice good housekeeping.
- Demonstrate working as a leader/a team member.
- Maintain tools and equipment.
- Follow ethical Practices

VI. Minimum Theoretical Background

Alloy steels are composed of iron and carbon with additional alloying elements such as molybdenum, manganese, nickel, chromium, vanadium, silicon, and boron. These alloying elements are added to increase strength, hardness, wear resistance, and toughness. The amounts of alloying elements may vary between 1 and 50%.

Therefore, the mechanical strength of medium carbon steels can be improved by quenching in appropriate medium. Comparisons of different quenchants in the heat-treatment processes of steels are of great usefulness in order to achieve desired hardness, strength or toughness, and to minimize the possibility of the occurrence of quench cracks due to the evolution of residual stresses. The choice of effective quenching medium following heat treatment is critical to ensuring the achievement of the desired mechanical properties; hence, the selection of a quenchant depends on the

quench sensitivity of a particular grade of steel and on the severity of the quench medium. Rapid cooling leads to the formation of martensite, which increases hardness but also brittleness. Time-Temperature-Transformation (TTT) diagrams help understand the kinetics of phase transformations and predict the microstructure resulting from different cooling rates.

VII. Experimental setup (Model)-

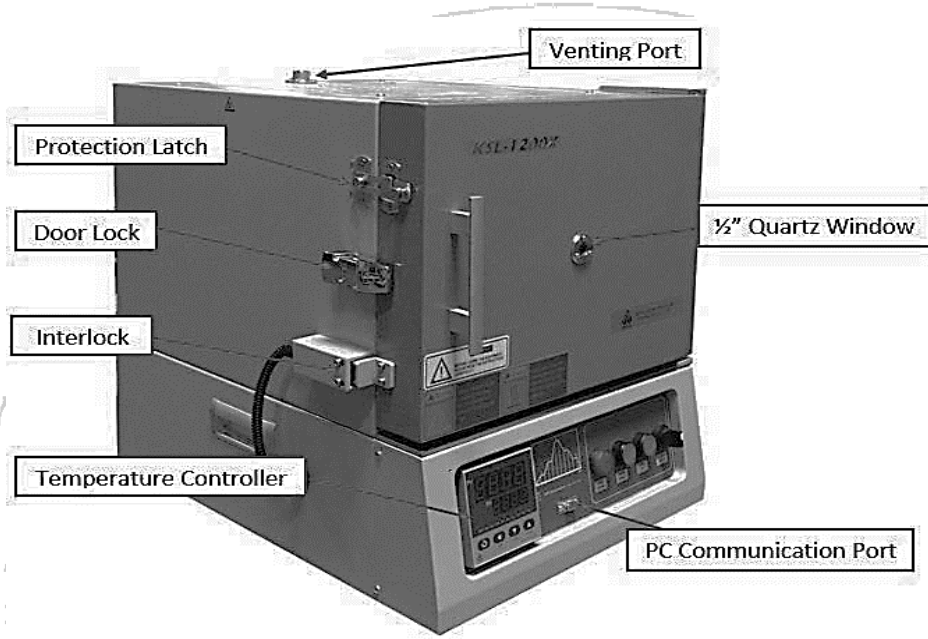

Fig15.1 Box Furnace

VIII. Required Resources /Apparatus/Equipment with specification

Sr.No.	Instrument /Components	Specification	Quantity
1	Laboratory box furnaces	1200°c	02
2	Digital Rockwell Hardness tester- Easy-to-use Electronics Console	Hi/Lo Tolerance Settings, Adjustable Time @ Load Average Test Group Results 2-9; Test Result Memory Capacity 5000 results, RS232 Output,- Average Range.	02

IX. Precautions to be Followed

- Always wear appropriate PPE, including heat-resistant gloves, lab coats, safety goggles, and face shields to protect against burns and splashes from hot materials and quenching liquids.
- Ensure the laboratory is well-ventilated to prevent the buildup of fumes from quenching oils or other hazardous vapors.
- Keep a fire extinguisher and first aid kit readily accessible. Familiarize yourself with the location and use of these safety tools.
- Use tongs or other heat-resistant tools to handle hot samples to avoid burns and thermal shock.
- Ensure all samples are of uniform size and shape to maintain consistency in heating and cooling.
- Clean samples thoroughly to remove any contaminants that could affect the heat treatment process
- For quenching, the sample should be immediately transferred from the furnace to the water/oil bath.
- For brine quenching, ensure the correct concentration of salt in the water.
- Be cautious of the potential for violent reactions, especially with water and brine, which can cause steam explosions.
- The quenching media should be agitated.
- The specimen should be well grinded and polished before measuring hardness.
- Hardness should be checked in cold state

X. Procedure

1. Prepare alloy steel samples of uniform size and shape to ensure consistent heating and quenching
2. Clean the samples to remove any surface contaminants.
3. Prepare three separate containers for oil, water, and brine quenching.
4. Ensure the brine solution has an appropriate salt concentration (e.g., 10% salt by weight).
5. Ensure each container has sufficient volume to fully submerge the samples.
6. Place the cleaned alloy steel samples into the furnace, ensuring they are evenly spaced and centrally located to ensure uniform heating.
7. Allow the samples to soak at the austenitizing temperature for the required time (e.g., 30-60 minutes) to achieve a homogeneous austenitic phase.
8. Remove one sample from the furnace using tongs or heat-resistant tools and immediately transfer it to the first quenching medium (e.g., oil). Ensure the sample is fully submerged.
9. Agitate the quenching medium gently to avoid vapor pockets and ensure uniform cooling.
10. Repeat the process for the remaining samples, quenching one in water and one in brine.
11. Select any two cooling medium for quenching.
12. Take out the samples one by one and immerse it in quenching mediums.
13. As sample gets cooled, its faces are ground and polished to get an even surface.
14. Perform hardness tests on each sample using a Rockwell hardness tester, following the standard procedure for the selected scale (e.g., Rockwell C). Alternatively, use Brinell if preferred.

15. Take multiple hardness measurements at different locations on each sample to ensure accuracy and repeatability.
16. Record the hardness values for each sample
17. Calculate the average hardness value for each sample.
18. Compare the hardness values to determine the effect of each quenching medium.
19. Check hardness and plot graph, if desired.

Selection of heat treatment conditions

Heating temperature	Soaking time	Quenching media
880°C, 920°C, 960°C	1 hour	Water, Brine, Oil or Air

**XI. Observations and calculations –
Brinell Hardness Number Before Quenching**

Sr.No	Specimen	Indenter Diameter(D) in mm	Total load(P) Kg-F	Diameter of Indentation(d) in mm			Average Dia.	BHN
				1	2	3		
1	Specimen-1							
2	Specimen-2							
3	Specimen-3							

Rockwell Hardness Number before Quenching

SR No	Specimen	Type of Indenter	Rockwell Hardness Number(RHN)			Avg. RHN
			1	2	3	
1	Specimen-4					
2	Specimen-5					
3	Specimen-6					

Measurement of Effect of Quenching on Hardness by Brinell Hardness Tester

Sr. No.	Material	Initial Hardness (BHN)	Hardness after quenching		
			Quenching Medium		
			Water	Brine	Oil
1	Specimen-1				
2	Specimen-2				
3	Specimen-3				

Measurement of Effect of Quenching on Hardness by Rockwell Hardness Tester

Sr. No.	Material	Initial Hardness (RHN)	Hardness after quenching		
			Quenching Medium		
			Water	Brine	Oil
1	Specimen -4				
2	Specimen -5				
3	Specimen-6				

Calculations:**Calculate Hardness Before quenching treatment:****Calculate Hardness After quenching treatment:**

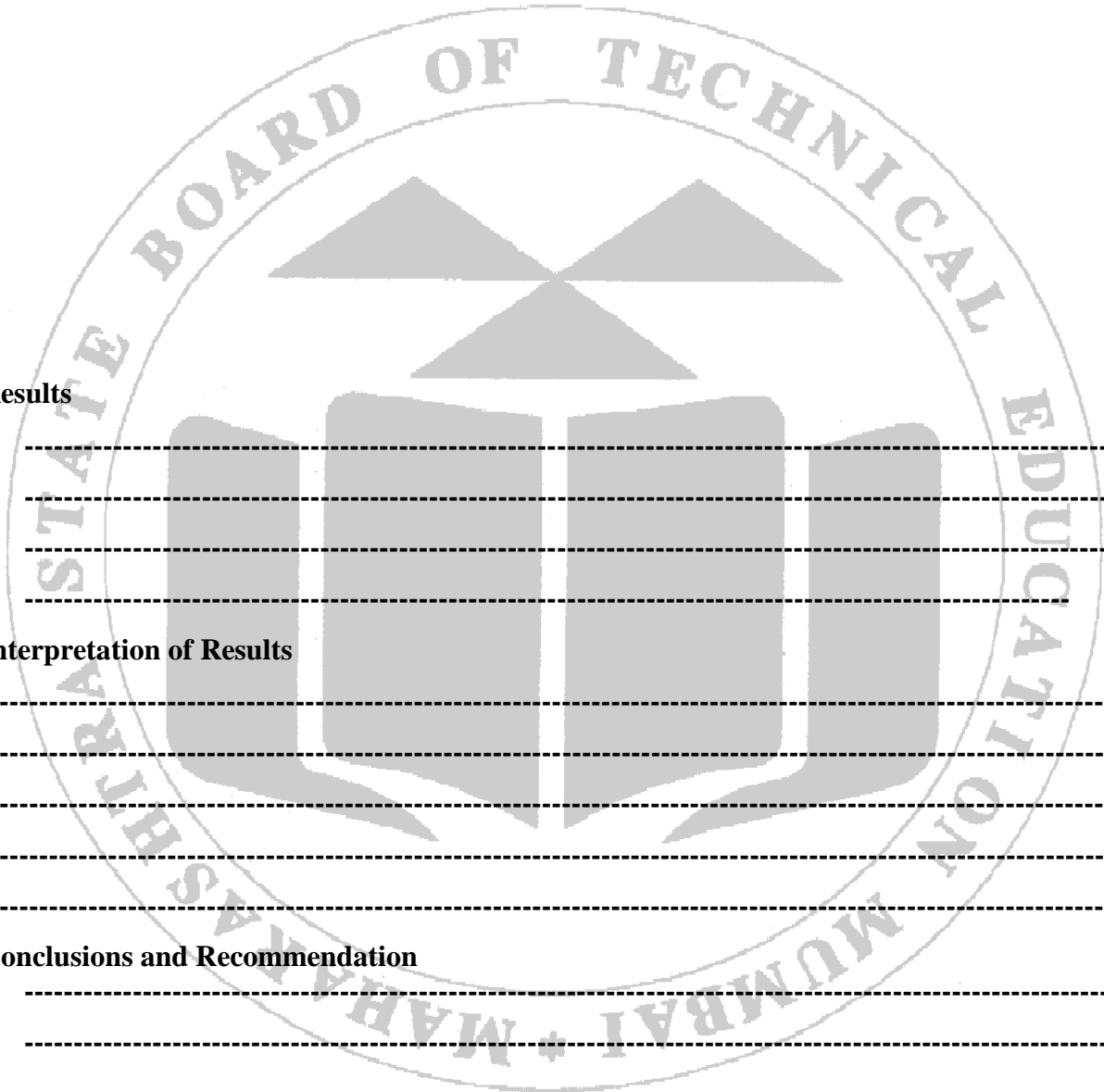

XII. Results

XIII. Interpretation of Results

XIV. Conclusions and Recommendation

XV. Practical Related Questions

Note: Below given are few sample questions for reference. Teachers must design more such questions so as to ensure the achievement of identified CO.

1. Define alloy steel and state its applications.
2. State the effect of salt concentration in brine
3. Draw a graph 'Hardness vs. tempering temperature for constant tempering time of 1 hour.
4. Some heat treated components develop cracks? Give reason
5. Explain heat treatment process in detail.
6. Explain effect of quenching media on hardness.
7. State composition of the alloy steel is used?
8. Explain how do the alloying elements influence the steel's response to heat treatment and quenching.
9. Explain How do the cooling rates of these mediums differ, and how might these differences affect the hardness of the alloy steel
10. Explain quenching medium resulted in the highest hardness, and why?
11. Explain how does the cooling rate of each medium affect the formation of martensite and other phases in the alloy steel.
12. Explain the practical implications of using different quenching mediums in industrial heat treatment processes.

[Space for Answer]

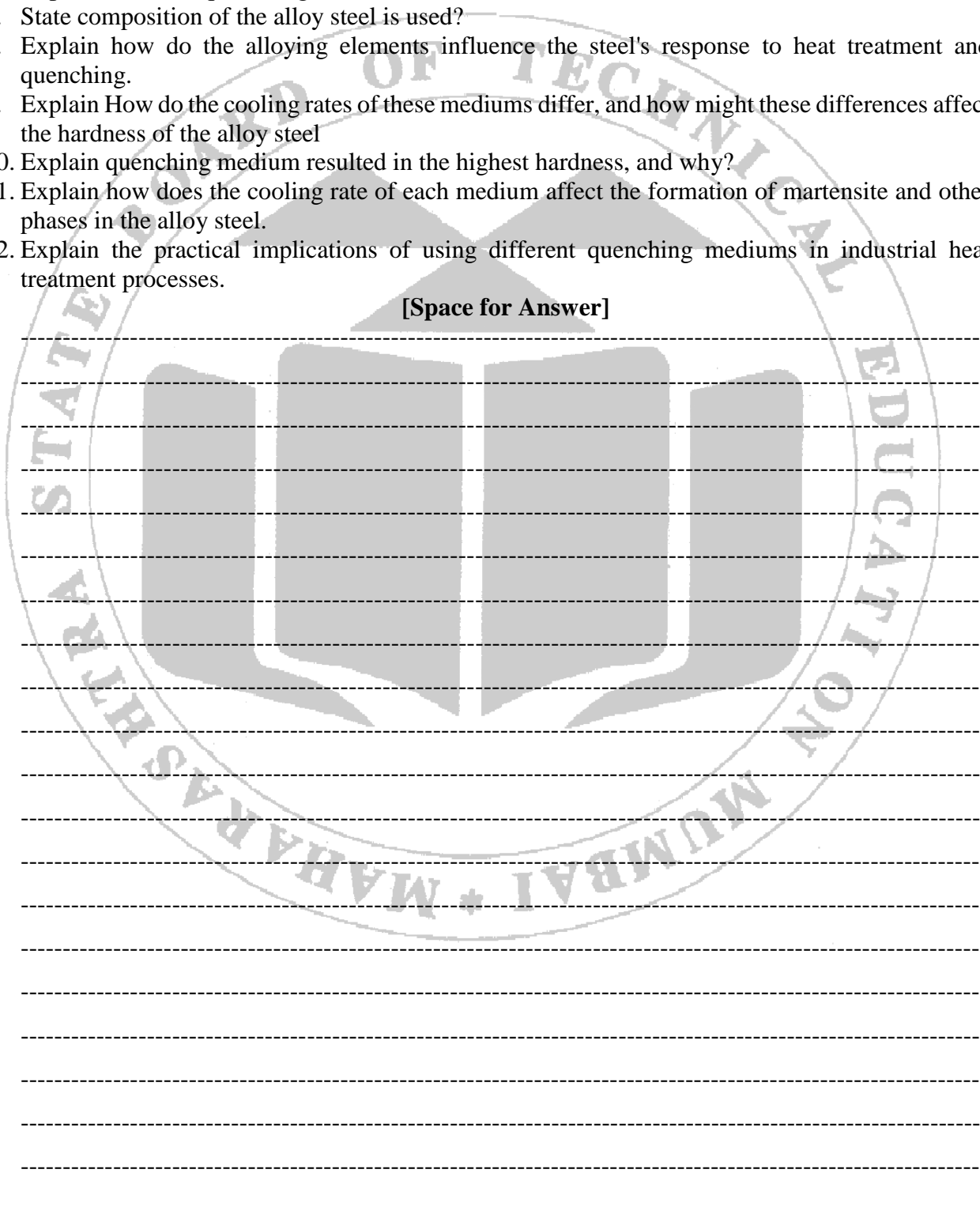

XVI. References / Suggestions for Further Reading

- <https://www.wikihow.com/Harden-Steel>
- <https://www.youtube.com/watch?v=QQ051Zie8pk>
- https://www.youtube.com/watch?v=Gmqkuc-n_IU
- <https://www.youtube.com/watch?v=UlpAtVgm8CO>
- <https://www.youtube.com/watch?v=U-DesKKNi9g>
- <https://www.youtube.com/watch?v=hw4RlOuG7ok>
- <https://www.youtube.com/watch?v=gPKkgmDoEoU>
- <https://www.youtube.com/watch?v=bkxVLI3ezwA>
- <https://www.youtube.com/watch?v=ulfCxDSVTWo>

XVII Rubrics for Assessment Scheme

Performance indicators		Weightage
Process related (15 Marks)		60%
1	Hardening of specimen	20
2	Quenching of specimen	20
3	Hardness measurement of specimen	20
Product related (10 Marks)		40%
4	Hardened specimen	20
5	Quenched specimen	20
Total (25Marks)		100%

Marks Obtained			Dated signature of Teacher
Process Related(15)	Product Related(10)	Total (25)	

Practical No. 16: Comparison of Ancient Indian material development processes with recent processes

I. Practical Significance

Man and metals have an age old relationship. Different periods of early human civilization have been named after metal. Material development is always driven by the necessity demanded of industries. Among various factors more crucial are the improvement in mechanical performance, reduction in the overall cost, and sometimes a synergy of both. Conventionally, every metallic material follows a casting route at the material development stage. Based on the application, it may be further subjected to metal working process or directly taken to the product development stage. However, with the current need in terms of properties, there is a large deviation from the traditional casting-based material development route. Ancient Indian material development processes, such as those used in metallurgy, textiles, and ceramics, offer insights into the advanced understanding of materials by early civilizations. Techniques like the production of Wootz steel and the use of natural dyes in textiles highlight sophisticated methods developed centuries ago. Studying these ancient techniques can inspire modern material scientists and engineers to revive and adapt traditional methods for contemporary applications. For instance, the unique properties of Wootz steel, known for its high carbon content and exceptional strength, can inform the development of advanced steel alloys today.

II. Industry/Employer Expected Outcome (s)

This practical is expected to develop the following skills for the industry/Employer.

1. To understand recent material development process and its application.
2. Apply innovative thinking to develop new materials and processes, improving product performance and efficiency.
3. Understanding ancient, eco-friendly processes instills a strong foundation in sustainable material development

III. Course Level Learning Outcome (CO)

CO1 - Select suitable material(s) based on desired properties according to application.

CO2 - Choose relevant alloy steel & Cast iron for mechanical components.

CO3 - Select relevant non ferrous & powder material components for the engineering application.

CO4 - Select relevant non metallic & advanced material for the engineering application.

CO5 - Use relevant heat treatment processes in given situations.

IV. Laboratory Learning Outcome(s)

- List various ancient Indian material development processes.
- Compare Ancient Indian material development processes with recent processes.

V. Relative Affective Domain Related Outcome(s)-

- Follow safety practices.
- Practice good housekeeping.
- Demonstrate working as a leader/a team member.
- Maintain tools and equipment.

- Follow ethical Practices

VI. Minimum Theoretical Background

Material development is a possible major approach for further optimization of cold-start performance. Emphasis can be made in particular on the nano-structure design of electrode materials, as well as graphene-based electrode materials. The trade-off between cold start ability and durability is one of the major issues that can be resolved through material development. Product development is a central part of new product introductions in a competitive market environment. This activity or phase is termed as the most critical in the growth and expansion of businesses and corporations. Through novel products and ideas, new companies are formed, become household names, and set the foundation for subsequent growth and innovation. There are numerous companies that have followed this pattern and many of them are case studies in product development and innovation.

Ancient Indian Material Development Processes

Metallurgy:

- **Wootz Steel:** Ancient Indian metallurgy is renowned for the production of Wootz steel, an early form of crucible steel with exceptional strength and sharpness. This steel was produced through a complex process involving the use of high-carbon iron ore and charcoal in sealed clay crucibles, followed by repeated heating and forging to refine its properties.
- **Copper and Bronze Casting:** Ancient Indian craftsmen mastered the art of casting copper and bronze alloys using techniques such as lost-wax casting. These processes allowed for the creation of intricate and durable artifacts, including sculptures, tools, and ceremonial objects.

Textiles:

- **Natural Dyes:** Ancient Indian textile production relied heavily on natural dyes sourced from plants, minerals, and insects. Artisans used techniques such as resist dyeing, block printing, and tie-dye to create rich and vibrant patterns on fabrics like cotton, silk, and wool.
- **Weaving:** Traditional Indian weaving methods, such as handloom weaving and ikat weaving, produced textiles of exceptional quality and intricacy. These techniques required skilled craftsmanship and intricate designs, often passed down through generations.

Ceramics:

- **Pottery:** Ancient Indian pottery was characterized by a diverse range of forms, styles, and techniques. Potters used various methods such as wheel throwing, coiling, and slab building to create vessels for everyday use, religious rituals, and trade. Kilns were used to fire pottery to high temperatures, resulting in durable and functional ceramic objects.

Recent Material Development Processes

Metallurgy:

- **Modern Steel Production:** In modern steel production, methods such as the Bessemer process, open-hearth process, and electric arc furnace process are used to produce steel on an industrial scale. These processes involve refining iron ore into molten steel, which is then cast or formed into various shapes and sizes.
- **Alloy Development:** Recent advancements in metallurgy have led to the development of specialized alloys with tailored properties for specific applications. Techniques such as alloying, heat treatment, and surface treatment are used to enhance the strength, durability, and corrosion resistance of metals.

Textiles:

- **Synthetic Dyes:** The introduction of synthetic dyes in the 19th century revolutionized the textile industry, allowing for the mass production of colorful and inexpensive fabrics. Synthetic dyes are chemically synthesized compounds that offer a wide range of colors and properties, making them popular for industrial textile production.
- **Mechanized Weaving:** The invention of mechanized looms and automated weaving machines has greatly increased the efficiency and output of textile production. Modern textile mills employ advanced weaving techniques and computerized systems to produce large quantities of fabric with high precision and consistency.

Ceramics:

- **Industrial Ceramic Production:** In modern ceramic production, advanced manufacturing techniques such as slip casting, pressure casting, and extrusion are used to produce ceramics on a large scale. These processes allow for the precise shaping and forming of ceramic products, ranging from tiles and sanitaryware to electronic components and aerospace materials.
- **Advanced Kiln Technology:** Modern kilns utilize advanced control systems and energy-efficient designs to optimize the firing process and reduce energy consumption. Techniques such as electric firing and gas firing allow for precise temperature control and uniform heating, resulting in high-quality ceramic products.

A comparison of ancient Indian material development processes with recent processes provides a framework for understanding the historical evolution, technological advancements, and cultural significance of material production. By examining the raw materials, techniques, environmental impact, quality, and cultural context of ancient and modern processes, researchers and industry professionals can gain valuable insights into the past, present, and future of material science and engineering.

VII. Observations

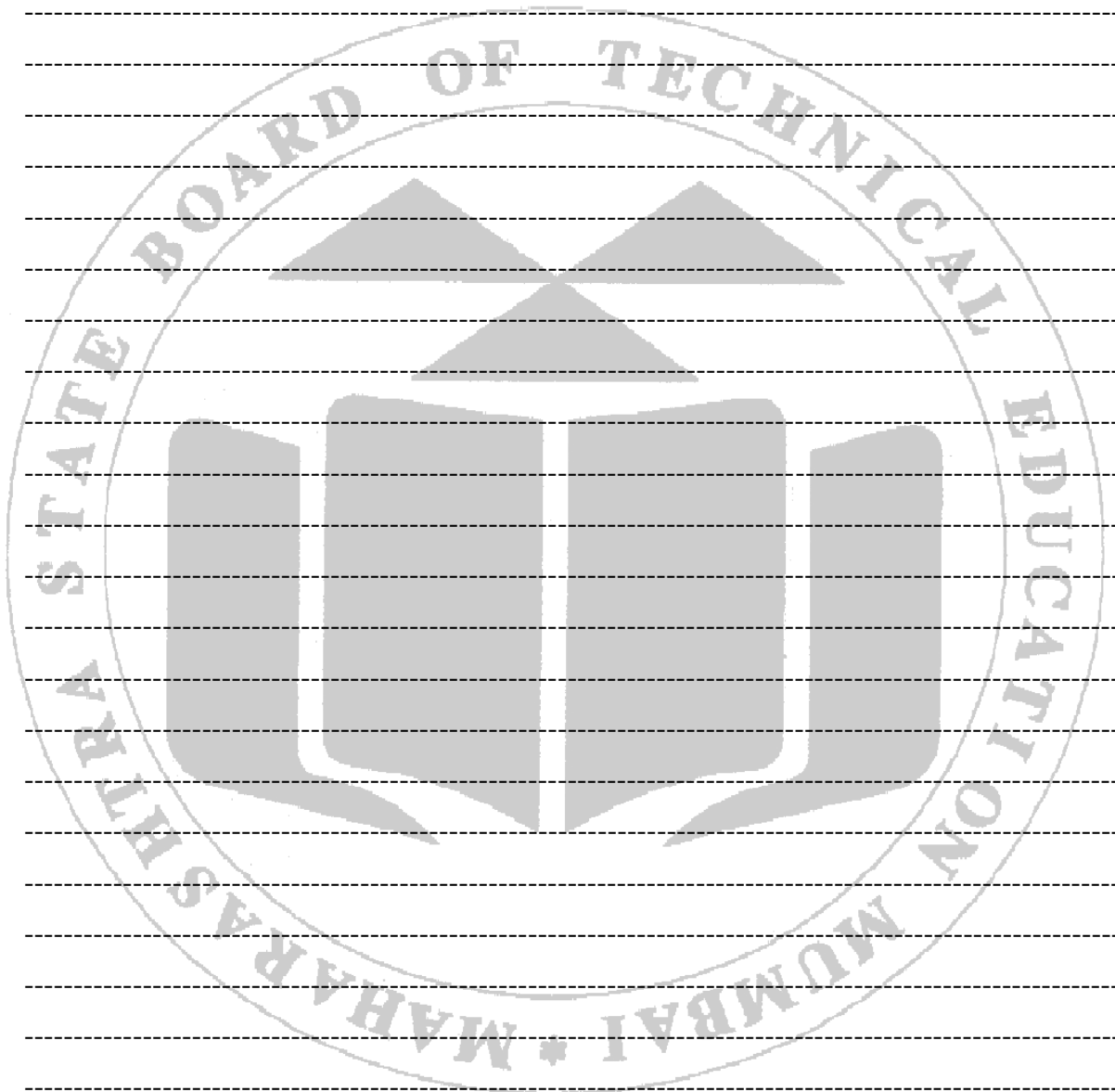

XI. References / Suggestions for Further Reading

- <https://vedicheritage.gov.in/vedic-heritage-in-present-context/metallurgy/>
- <https://www.youtube.com/watch?v=04K0bLwCDdM>
- https://www.youtube.com/watch?v=_eM49JlmFp0

XVII Rubrics for Assessment Scheme

Performance Indicators		Weightage
Process Related (15 Marks)		(60%)
1	Handling of the measuring Instruments	30%
2	Observations/Calculation of final readings	30%
Product Related (10 Marks)		(40%)
3	Interpretation of result	15%
4	Conclusions	15%
5	Practical related questions	10%
Total (25 marks)		100 %

Marks Obtained			Dated signature of Teacher
Process Related(15)	Product Related(10)	Total (25)	