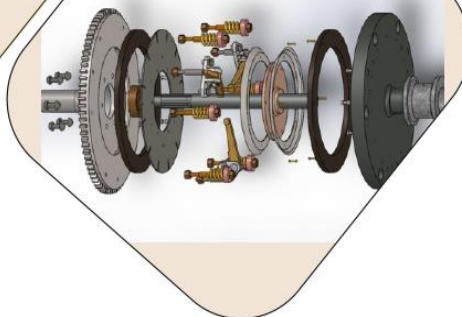
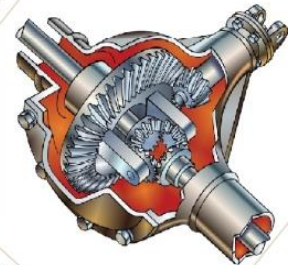
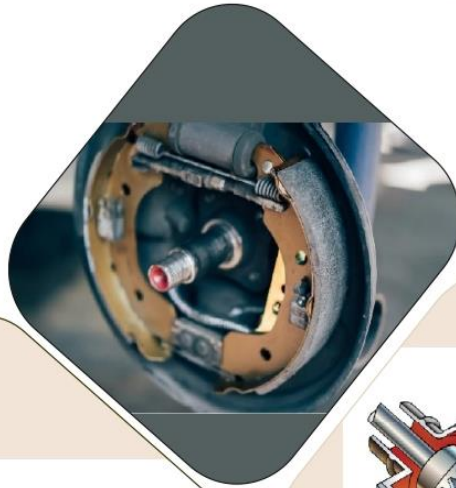


**SCHEME :K**

Name : \_\_\_\_\_  
Roll No.: \_\_\_\_\_ Year : 20 \_\_ 20 \_\_  
Exam Seat No. : \_\_\_\_\_

# LABORATORY MANUAL FOR AUTOMOBILE ENGINEERING (315372)



**MECHANICAL ENGINEERING GROUP**



**MAHARASHTRA STATE BOARD OF  
TECHNICAL EDUCATION, MUMBAI  
(Autonomous)(ISO21001:2018)(ISO/IEC27001:2013)**

## **VISION:**

To ensure that the Diploma level technical education constantly matches the latest requirements of Technology and industry and includes the all-round personal development of students including social concerns and to become globally competitive, technology led organization.

## **MISSION:**

To provide high quality technical and managerial manpower, information and consultancy services to the industry and community to enable the industry and community to face the challenging technological & environmental challenges.

## **QUALITY POLICY:**

We, at MSBTE are committed to offer the best in class academic services to the students and institutes to enhance the delight of industry and society. This will be achieved through continual improvement in management practices adopted in the process of curriculum design, development, implementation, evaluation and monitoring system along with adequate faculty development programmes.

## **CORE VALUES:**

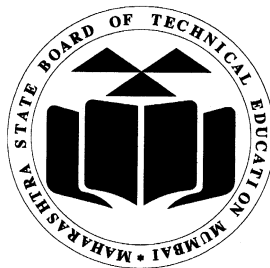
**MSBTE believes in the following:**

- Skill development in line with industry requirements.
- Industry readiness and improved employability of Diploma holders.
- Synergistic relationship with industry.
- Collective and Cooperative development of all stake holders.
- Technological interventions in societal development.
- Access to uniform quality technical education.

**A Practical Manual for**  
**Automobile Engineering**  
**(315372)**

**Semester– (V)**  
**“K-SCHEME”**

**(Diploma in Mechanical Engineering)**  
**(ME)**



**Maharashtra State**  
**Board of Technical Education, Mumbai**  
**(Autonomous) (ISO-21001-2018) (ISO/IEC 27001:2013)**



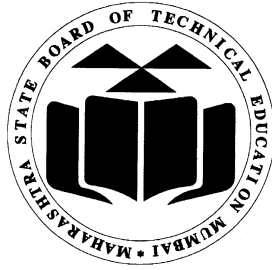
## **Maharashtra State Board of Technical Education, Mumbai**

**(Autonomous) (ISO: 21001: 2018) (ISO/IEC 27001:2013)**

4<sup>th</sup> Floor, Government Polytechnic Building, 49, Kherwadi,

Bandra (East), Mumbai – 400051,

(Printed on July, 2025)



# Maharashtra State Board of Technical Education, Mumbai

## Certificate

This is to certify that Mr. / Ms. .... Roll  
No..... of Fifth Semester of Diploma in  
..... of Institute  
.....  
(Code.....) has completed the term work satisfactorily in  
course **AUTOMOBILE ENGINEERING (315372)** for the academic year  
20.....to 20..... as prescribed in the curriculum.

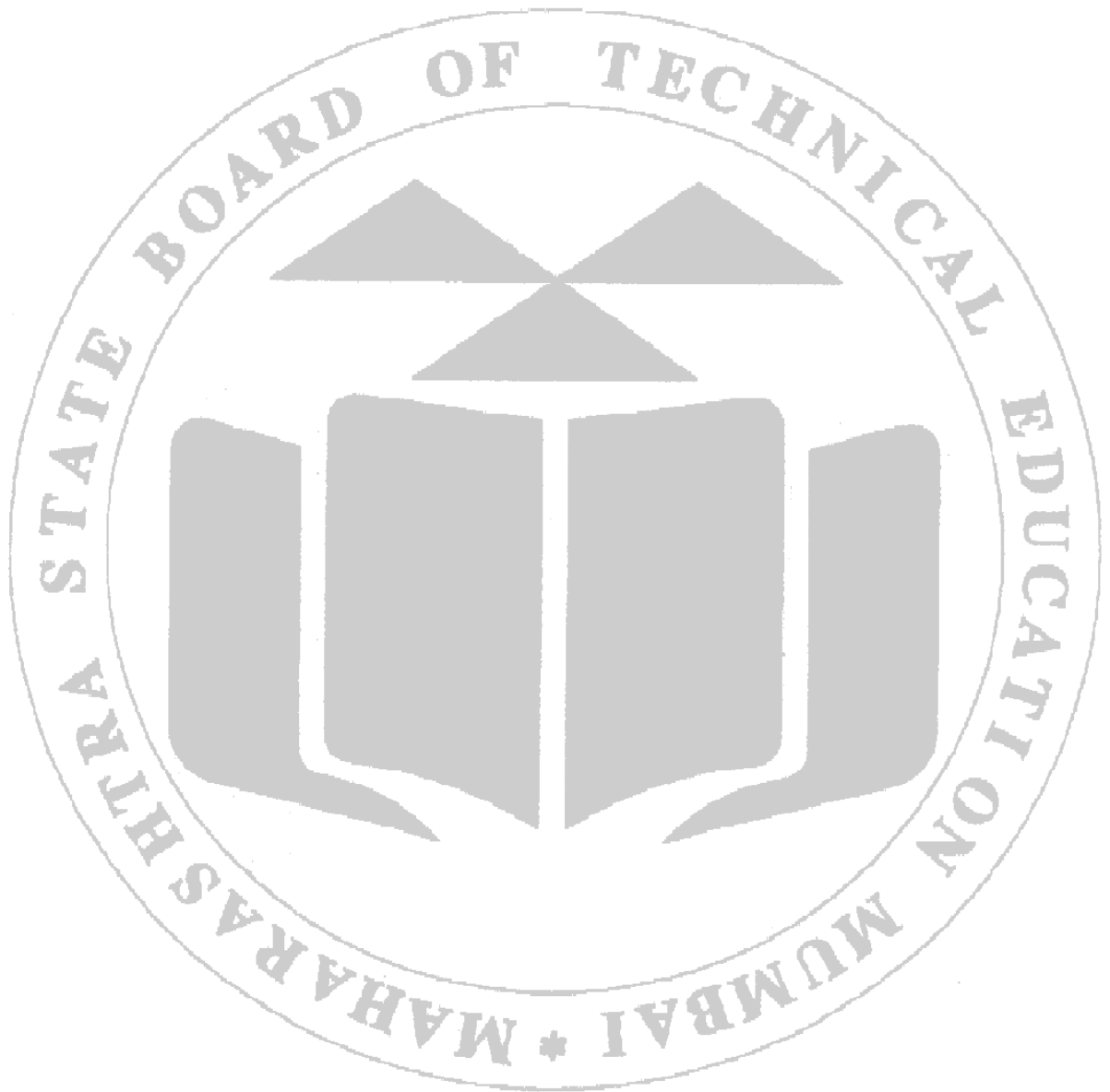
Place: ..... Enrollment No.....  
Date: ..... Exam Seat No. ....

**Course Teacher**

**Head of the Department**

**Principal**





## Preface

The primary focus of any engineering laboratory/ field work in the technical education system is to develop the much-needed industry relevant competencies and skills. With this in view, MSBTE embarked on this innovative 'K' Scheme curricula for engineering diploma programme with National Education Policy 2020 (NEP 2020) and outcome-based education as the focus and accordingly, relatively large amount of time is allotted for the practical work. This displays the great importance of laboratory work making each teacher; instructor and student to realize that every minute of the laboratory time need to be effectively utilized to develop these outcomes, rather than doing other mundane activities. Therefore, for the successful implementation of this outcome-based curriculum, every practical has been designed to serve as a '*vehicle*' to develop this industry identified competency in every student. Accordingly, the 'K' scheme laboratory manual development team designed the practical to *focus* on the *outcomes*, rather than the traditional age-old practice of conducting practical to 'verify the theory' (which may become a byproduct along the way).

This laboratory manual is designed to help all stakeholders, especially the students, teachers and instructors to develop in the student the pre-determined outcomes. It is expected from each student that at least a day in advance, they have to thoroughly read through the concerned practical procedure that they will do the next day and understand the minimum theoretical background associated with the practical. Every practical in this manual begins by identifying the competency, industry relevant skills, course outcomes and practical outcomes which serve as a key focal point for doing the practical. The students will then become aware about the skills they will achieve through procedure shown there and necessary precautions to be taken, which will help them to apply in solving real-world problems in their professional life.

This manual also provides guidelines to teachers and instructors to effectively facilitate student-centered lab activities through each practical exercise by arranging and managing necessary resources in order that the students follow the procedures and precautions systematically ensuring the achievement of outcomes in the students.

Knowledge of identify automobile components and automobile systems is a pre-requisite for enabling a mechanical engineer to work in an industry. This course provides the knowledge of vehicle layout such as front engine rear wheel drive, front engine front wheel drive, automobile transmission system, control system suspension wheels, tyres and basics of auto electrical system to enable a diploma holder to carry out maintenance of these and this knowledge will helpful to the students in correlating various automobile systems and with each other and provide good practical input with theoretical knowledge for technical advancement of industry/society.

The Practical manual development team wishes to thank MSBTE who took initiative in the development of curriculum and implementation and also acknowledge the contribution of individual course experts who have been involved in laboratory manual as well as curriculum development (K scheme) directly or indirectly.

Although all care has been taken to check for mistakes in this laboratory manual, yet it is impossible to claim perfection especially as this is the first edition. Any such errors and suggestions for improvement can be brought to our notice and are highly welcome.

**Lab Manual Development Team**

**Programme Outcomes (POs) to be achieved through Practical of this Course**

Following POs are expected to be achieved through the practicals of the (Automobile Engineering) course.

**PO1. Basic and Discipline specific knowledge:** Apply knowledge of basic mathematics, science and engineering fundamentals and engineering specialization to solve the mechanical engineering problems.

**PO2. Problem analysis:** Identify and analyse well-defined mechanical engineering problems using codified standard methods.

**PO3. Design/ development of solutions:** Design solutions for well-defined technical problems and assist with the design of systems components or processes to meet specified needs in mechanical engineering.

**PO4. Engineering Tools, Experimentation and Testing:** Apply modern mechanical engineering tools and appropriate technique to conduct standard tests and measurements.

**PO5. Engineering practices for society, sustainability and environment:** Apply appropriate technology in context of society, sustainability, environment and ethical practices.

**PO6. Project Management:** Use engineering management principles individually, as a team member or a leader to manage projects and effectively communicate about well-defined engineering activities in diverse and multidisciplinary fields.

**PO7. Life-long learning:** Ability to analyse individual needs and engage in updating in the context of technological changes in mechanical engineering.

**List of Industry Relevant Skills-**

The following industry relevant skills or the competency “Maintain various systems of an automobile” are expected to be developed in you by undertaking the practical’s of this laboratory manual.

1. Identify various components of an automobile.
2. Understand the working of different automobile systems.
3. Dismantle and assemble automobile components.
4. Carry out basic maintenance procedures.
5. Diagnose simple faults in automotive systems.
6. Perform measurements and inspection of automotive components.
7. Interpret service manuals, wiring diagrams, and technical data sheets.
8. Ensure safety and proper housekeeping in the workshop and tools and equipments.
9. Understand basic automobile electrical and electronic systems.
10. Communicate effectively using technical language in a workshop environment.

**Practical- Course Outcome matrix****Course Outcomes (COs)**

CO1- Use appropriate tools for vehicle service operation.

CO2- Carryout repairing activities by following laid down procedures.

CO3- Diagnose faults in given automobile control systems.

CO4- Locate faults in suspension system of given automobile.

CO5- Carryout appropriate test for given auto electrical and electronic components.

Sr. No.	Laboratory Practical Titles	CO1	CO2	CO3	CO4	CO5
1	Preparation of Layout of given vehicle.	√	-	-	-	-
2	*Use appropriate tools for service applications.	√	-	-	-	-
3	*Dismantling and Assembling of Clutch.	-	√	-	-	-
4	Dismantling and Assembling Gear Box.	-	√	-	-	-
5	Dismantling and Assembling Differential unit.	-	√	-	-	-
6	*Repair drum /Disc Brake.	-	-	√	-	-
7	Steering system.	-	-	√	-	-
8	*Suspension system.	-	-	-	√	-
9	*Carry out battery test.	-	-	-	-	√
10	Wheel balancing and wheel alignment.	-	-	-	√	-

### Guidelines to Teachers

1. **Teacher need to ensure that a dated log book** for the whole semester, apart from the laboratory manual is maintained by every student which s/he has to **submit for assessment to the teacher** in the next practical session.
2. There will be two sheets of blank pages after every practical for the student to report other matters (if any), which is not mentioned in the printed practical.
3. For difficult practical if required, teacher could provide the demonstration of the practical emphasizing of the skills which the student should achieve.
4. Teachers should give opportunity to students for hands-on after the demonstration.
5. Assess the skill achievement of the students and COs of each unit.
6. One or two questions ought to be added in each practical for different batches. For this teacher can maintain various practical related question banks for each course.
7. If some repetitive information like data sheet, use of software tools etc. has to be provided for effective attainment of practical outcomes, they can be incorporated in Appendix.
8. For effective implementation and attainment of practical outcomes, teacher ought to ensure that in the beginning itself of each practical, students must read through the complete write-up of that practical sheet.
9. During practical, ensure that each student gets chance and takes active part in taking observations/readings and performing practical.
10. Teacher ought to assess the performance of students continuously according to the MSBTE guidelines

### Instructions for Students

1. For incidental writing on the day of each practical session every student should maintain a **dated log book** for the whole semester, apart from this laboratory manual which s/he has to **submit for assessment to the teacher** in the next practical session.
2. For effective implementation and attainment of practical outcomes, in the beginning itself of each practical, students need to read through the complete write-up including the practical related questions and assessment scheme of that practical sheet.
3. Student ought to refer the data books, IS codes, Safety norms, Technical Manuals, etc.
4. Student should not hesitate to ask any difficulties they face during the conduct of practical.

**Content Page****List of Practical and Progressive Assessment Sheet**

Sr. No	Laboratory Practical Titles	Page No.	Date of performance	Date of submission	FA PR marks (25)	Dated sign. of teacher	Remarks (if any)
1.	Preparation of Layout of given vehicle.	1					
2.	*Use appropriate tools for service applications.	8					
3.	*Dismantling and Assembling of Clutch.	18					
4.	Dismantling and Assembling Gear Box.	30					
5.	Dismantling and Assembling Differential unit.	38					
6.	*Repair drum /Disc Brake.	45					
7.	Steering system.	54					
8.	*Suspension system.	62					
9.	*Carry out battery test.	69					
10.	Wheel balancing and wheel alignment.	76					

*Note: To be transferred to Proforma of CIAAN-2023.*

**A suggestive list of LLOs is given in the above table. More such LLOs can be added to attain the COs and competency. A judicious mix of minimum 80 % or more practical need to be performed, out of which, the practical marked as ‘\*’ are compulsory, so that the student reaches the ‘Precision Level’ of Dave’s ‘Psychomotor Domain Taxonomy’ as generally required by the industry.**

**Practical No. 01: Preparation of Layout of given vehicle.****I. Practical Significance**

Understanding the vehicle layout provides foundational knowledge about the placement and relationship of major automotive components. It aids in visualizing the system integration of engines, transmissions, suspensions and electrical subsystems.

**II. Industry/Employer Expected Outcome(s)**

This practical is expected to develop the following skills for the industry/Employer

1. Ability to interpret and sketch automotive layouts.
2. Familiarity with vehicle systems and their interconnection.
3. Readiness for practical maintenance and diagnostic tasks in the industry.

**III. Course Level Learning Outcome (CO)**

CO1- Use appropriate tools for vehicle service operation.

**IV. Laboratory Learning Outcome(s)**

1. Identify Automobile systems like Transmission, Control, Suspension, Electrical and Electronics.
2. Draw layout of given vehicles.
3. Compare various layouts.

**V. Relative Affective Domain Related Outcome(s)**

1. Follow safety practices.
2. Demonstrate working as a leader/a team member.
3. Maintain tools and equipment.
4. Follow ethical Practices.

**VI. Minimum Theoretical Background with diagram****Vehicle Layout:**

Vehicle layout refers to the positioning of major components such as the engine, transmission, drive shaft and axles. -Common layouts:

- Front-engine front-wheel drive (FEFWD)
- Front-engine rear-wheel drive (FERWD)
- Rear-engine rear-wheel drive (RERWD)
- All-wheel drive (AWD) or Four Wheel Drive (FWD).

## Diagram

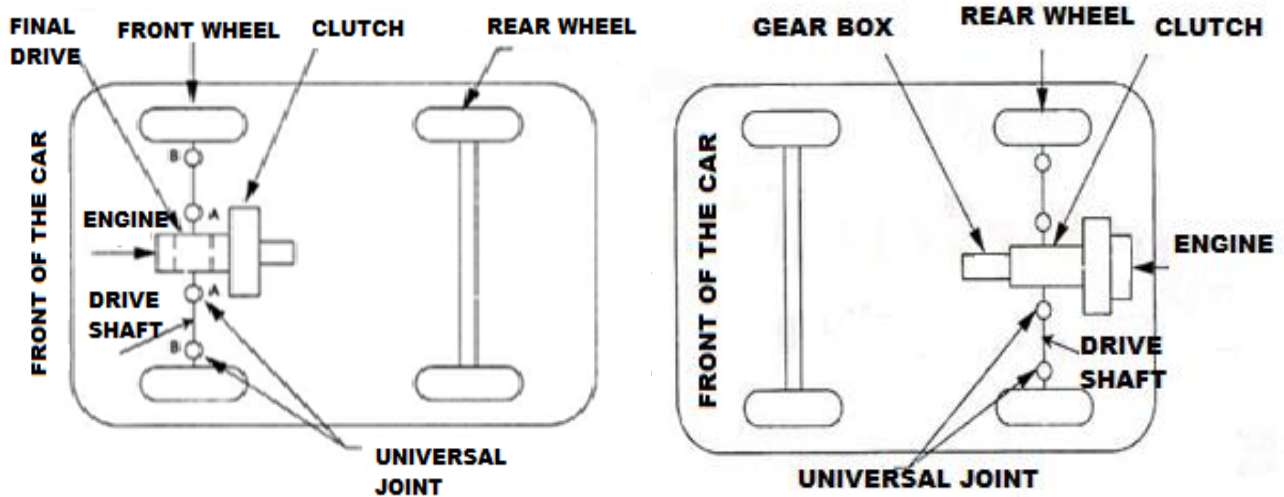


Fig.1.1 Front Engine Front Wheel Drive    Fig.1.2 Rear Engine Rear Wheel Drive

## Application:

- Front engine Front wheel drive is common in compact cars due to better space efficiency.
  - Rear Engine Rear Wheel Drive is often used in sports cars and high-performance vehicle.
- Thus, the layout of a vehicle consists of engine, followed by clutch, gearbox, propeller shaft, universal joint, differential and axles.
1. **Engine** – The engine is the power-generating unit of the vehicle that converts fuel into mechanical energy.
  2. **Clutch** – The clutch connects and disconnects the engine from the transmission system, allowing smooth gear changes
  3. **Gearbox (Transmission)** – The gearbox adjusts the engine's output speed and torque to suit different driving conditions.
  4. **Propeller Shaft** – The propeller shaft transmits rotational power from the gearbox to the differential at the rear axle.
  5. **Universal Joint** – The universal joint allows the propeller shaft to flex and transmit power smoothly despite changes in angle due to road conditions or suspension movement.
  6. **Differential** – The differential splits the engine torque between the left and right wheels while allowing them to rotate at different speeds during turns.
  7. **Axles** – Axles transfer power from the differential to the wheels, supporting vehicle weight and enabling wheel rotation.
    - a) **Rear Axle** – The rear axle transmits power from the differential to the rear wheels and supports the rear of the vehicle.
    - b) **Front Axle** – The front axle supports the front of the vehicle and enables steering while bearing the weight and absorbing road shocks.

## VII. Experimental setup

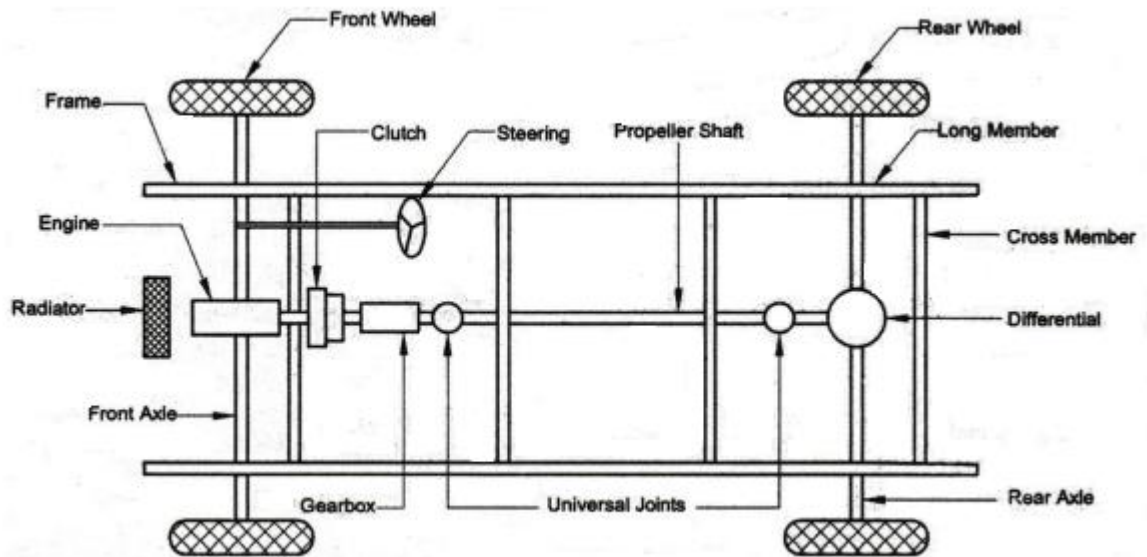


Fig 1.3 General Vehicle Layout and Components

## VIII. Required Resources /Apparatus/Equipment with specification

Sr. No.	Name of Resource	Suggested Broad Specification	Quantity
1.	Front Engine Front Wheel Drive(LMV)	A 800 cc above car of make Four Wheeler car make Maruti /Mahindra /TATA	01
2.	Front Engine Rear Wheel Drive (LMV)	A Light motor vehicle of make Mahindra /TATA /Ashok Leyland.	01
3.	Four Wheel Drive(LMV)	Mahindra Jeep	01

## IX. Precautions to be followed

1. Ensure the vehicle is stationary with the handbrake on.
2. Refer the service manual of the given vehicle.

## X. Procedure

1. Select the vehicle for layout study.
2. Inspect and identify the major components.
3. Sketch the given vehicle layout-
  - i. Engine position.
  - ii. Transmission line.
  - iii. Suspension.
  - iv. Steering system.

- v. Brakes.
4. Label each component.
5. Compare the given layout.

**XI. Observations:**

Student shall observe various vehicles of each category and identify the chassis layout and write it in observation table.

**a) Write the details layout of given vehicle**

Sr. No.	Name of Vehicle	Type of Layout Used
1.	Maruti 800	Front Engine Front Wheel Drive
2.	Mahindra Scorpio	
3.	Hyundai Verna	
4.	Mahindra Thar	
5.	TATA Nano	
6.	Honda City	
7.	Hyundai Creta	
8.	Maruti van	

**b) Sketch the layout of the observed vehicle**

**XII. Results**

-----  
 -----  
 -----  
 -----

**XIII. Interpretation of Results**

-----  
 -----  
 -----  
 -----

**XIV. Conclusions and Recommendation**

-----  
 -----  
 -----  
 -----  
 -----

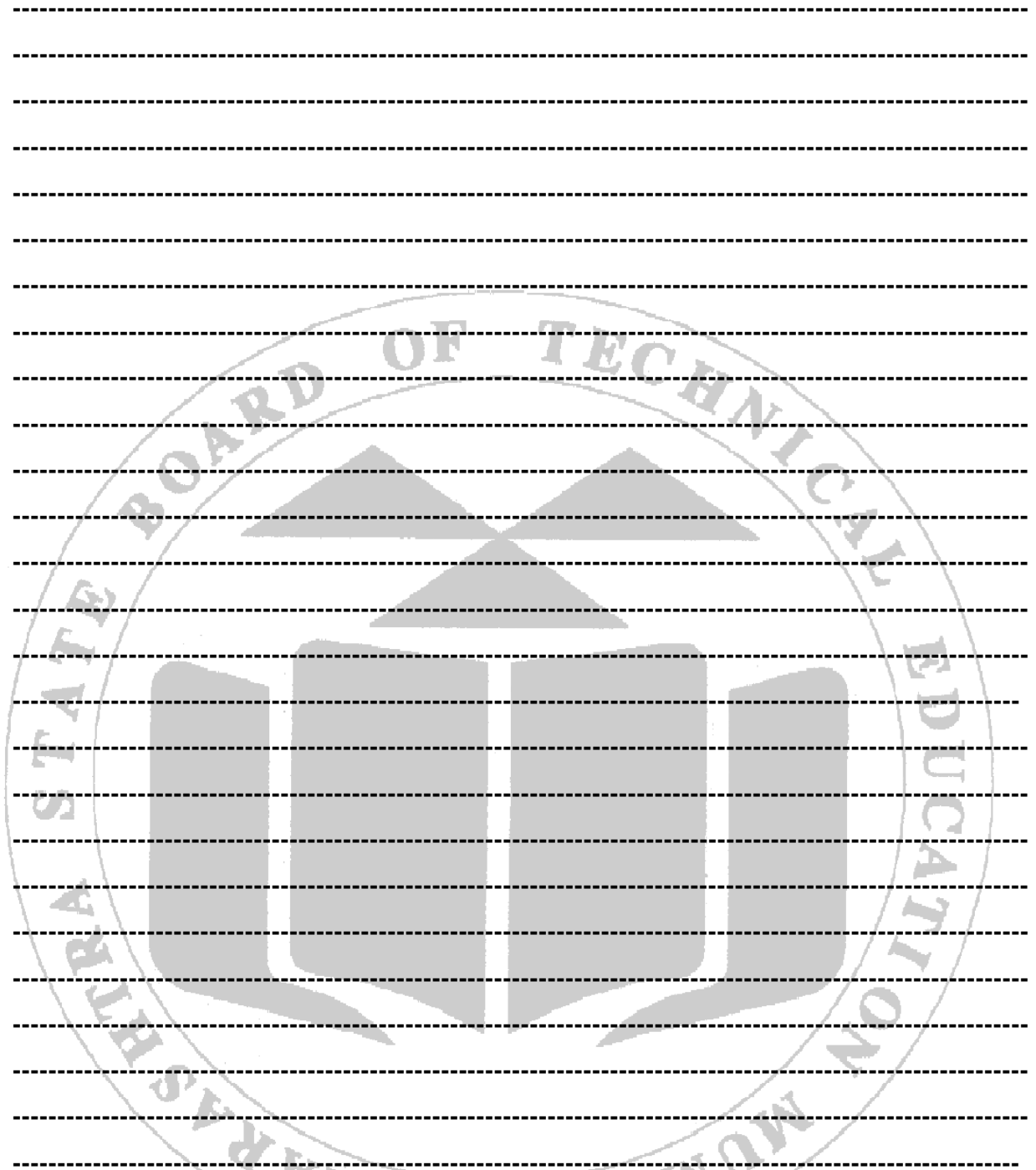
**XV. Practical Related Questions**

*Note: Below given are few sample questions for reference. Teachers must design more such questions so as to ensure the achievement of identified CO.*

1. List any two vehicles which used 4WD.
2. State two advantages and disadvantages of FEFWD and FERWD vehicle.
3. Sketch the layout of 4WD vehicle.
4. Compare between FERWD and RERWD on the basis of,
  - a) Location of engine b) weight distribution c) Complexity d) Applications.

[Space for Answer]

-----  
 -----  
 -----  
 -----  
 -----  
 -----

**XVI. References / Suggestions for Further Reading**

1. <https://www.youtube.com/watch?v=kNuf1kfXgr4>
2. <https://www.youtube.com/watch?v=9VQNLj5ZDZM>
3. <https://www.youtube.com/watch?v=ChsK7sXMsZk>
4. <https://www.youtube.com/watch?v=HaTO67c7haQ>

**XVII. Rubrics for Assessment Scheme**

<b>Performance Indicators</b>		<b>Weightage</b>
<b>Process Related (15 Marks)</b>		<b>(60%)</b>
1.	Preparation of Practical set up, Safety measures and standard practices	20%
2.	Handling of service tools carefully while performing the practical.	20%
3.	Identify the probable Causes of the Troubles ,Inspection, Record Keeping, Reassembly	20%
<b>Product Related (10 Marks)</b>		<b>(40%)</b>
4.	Interpretation of result	20%
5.	Conclusions	10%
6.	Practical related questions	10%
<b>Total</b>		<b>100 %</b>

<b>Marks Obtained</b>			<b>Dated signature of Teacher</b>
<b>Process Related (15)</b>	<b>Product Related (10)</b>	<b>Total (25)</b>	

## Practical No: 02: \* Use Appropriate Tools for Service Applications.

### I. Practical Significance

Using the correct tools in automotive service operations ensures safety, accuracy and efficiency during repair, maintenance and diagnostics of vehicle components.

### II. Industry/Employer Expected Outcome(s)

This practical is expected to develop the following skills for the industry/Employer

1. Technicians should identify, select and correctly use automotive hand tools, power tools and diagnostic instruments.
2. Perform maintenance and repair tasks with precision using proper service tools.
3. Minimize damage to components due to improper tool usage.

### III. Course Level Learning Outcome (CO)

CO1- Use appropriate tools for vehicle service operation.

### IV. Laboratory Learning Outcome(s)

1. Select various tools available in laboratory.
2. Categorize tools available in laboratory.

### V. Relative Affective Domain Related Outcome(s)

1. Follow safety practices.
2. Demonstrate working as a leader/a team member.
3. Maintain tools and equipments.

### VI. Minimum Theoretical Background with diagram

Some commonly used hand tools, measuring tools and special tools are given below-

#### a) Hand tools:

1. **Screw drivers:** Used to tightening and loosening screws. These are available in flat blade (slotted head) and Phillips head with various sizes. Always select a screwdriver of proper size for the job. When using a flat blade screwdriver, the blade should completely fill the screw slot. This helps to prevent damages

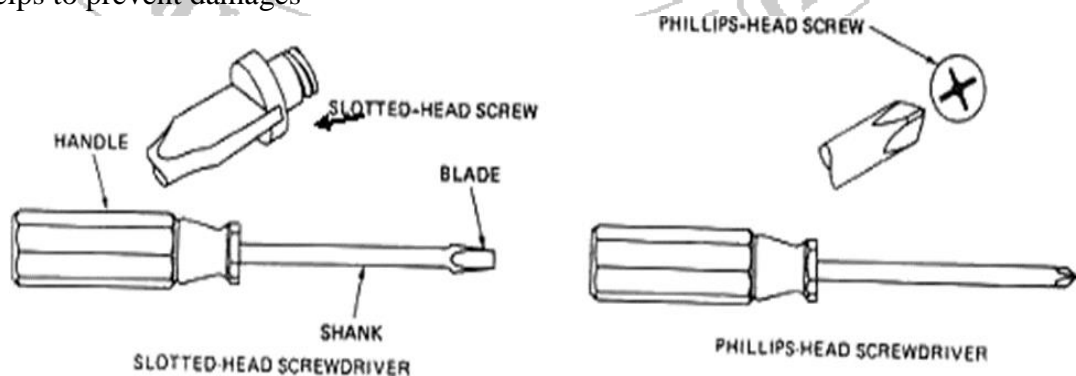


Fig.2.1 Screw Drivers

2. **Spanners:** Used to tighten or loosen the nut and bolts.

**Open ended spanner:**

It has a jaw opening at a  $15^{\circ}$  angle to the handle. It has different sizes on each end. It is used where space restriction is there. Make sure the spanner fits snugly against the bolt or nut a loose fit may cause slipping of spanner thereby causing injury to mechanic.



**Fig.2.2 Open ended spanner**

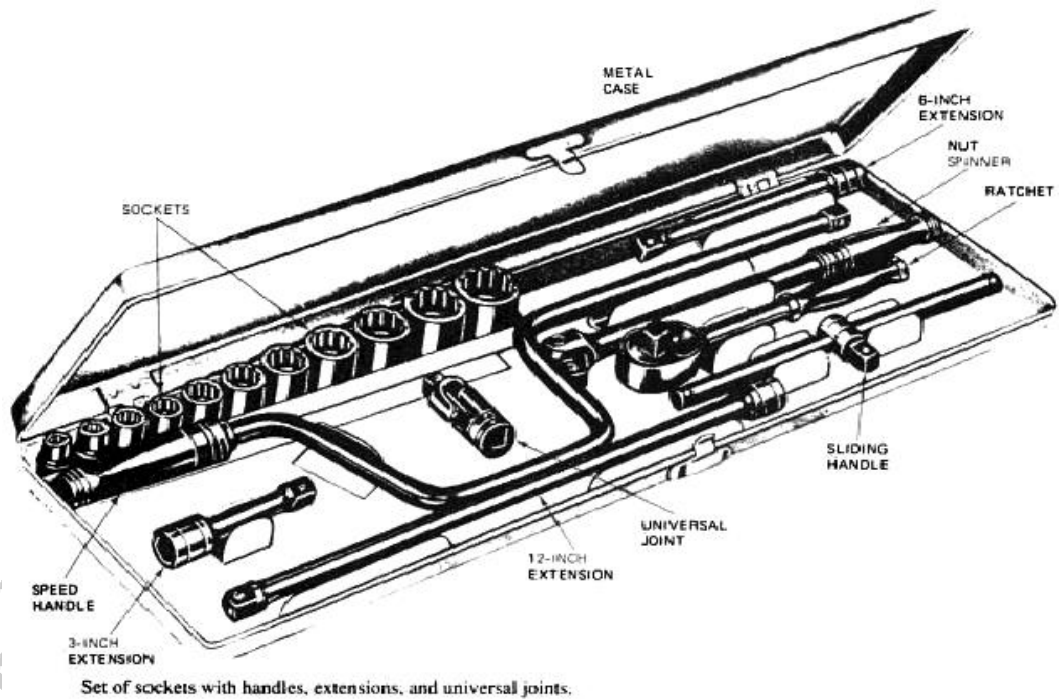
**Ring spanner:** It surrounds the nut or bolt head. It consists of twelve notches which help to hold the bolt properly without slipping.



**Fig.2.3 Ring spanner**

**Box Spanner:** It surrounds the nut or bolt head. It does not slip off.

3. **Socket Spanner Set:** These are most widely used tools in shop. It consists of set of sockets, handle, nut and ratchet.



**Fig.2.4 Box spanner**

4. **Hammers and Mallets:** Hammer is a hand tool used for striking. These are used to make the surface flat. Most commonly used hammer is ball-peen hammer. Care Should be taken not to hit the object at an angle.



**Fig.2.5 Hammers & Mallets**

5. **Pliers:** Pliers are hand tools with a pair of adjustable jaws for cutting or gripping. The Snapping pliers are used to remove circlips or snap-rings on the shafts or piston pin. Never use pliers on nut or bolts heads these may damage the head.

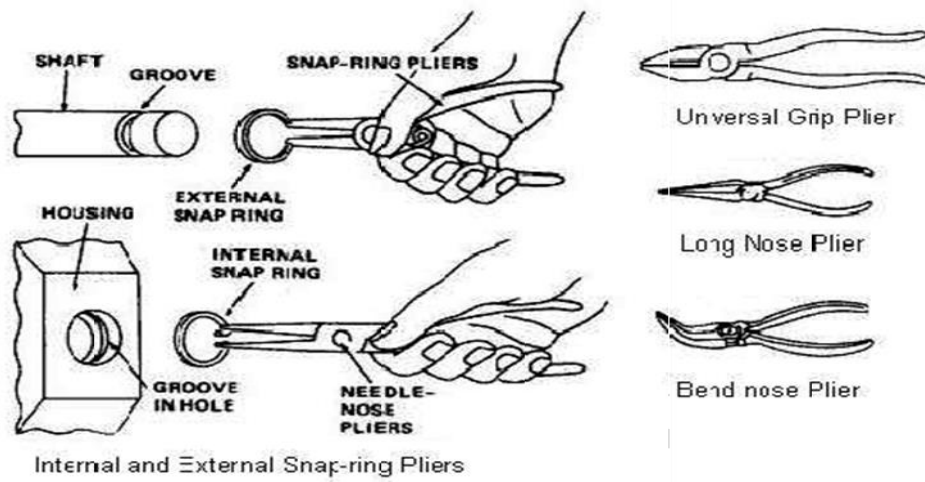


Fig.2.6 Pliers

6. Chisels:

A chisel is a tool with a cutting edge often made of steel used for cutting or shaping materials like wood, stone or metal.



Fig.2.7 Chisel

b) Measuring Tools:

These are used to measure the dimensions of components so as to identify worn or damaged parts of automobile.

1. **Vernier Calliper:** To measure inside and outside dimension of the components.

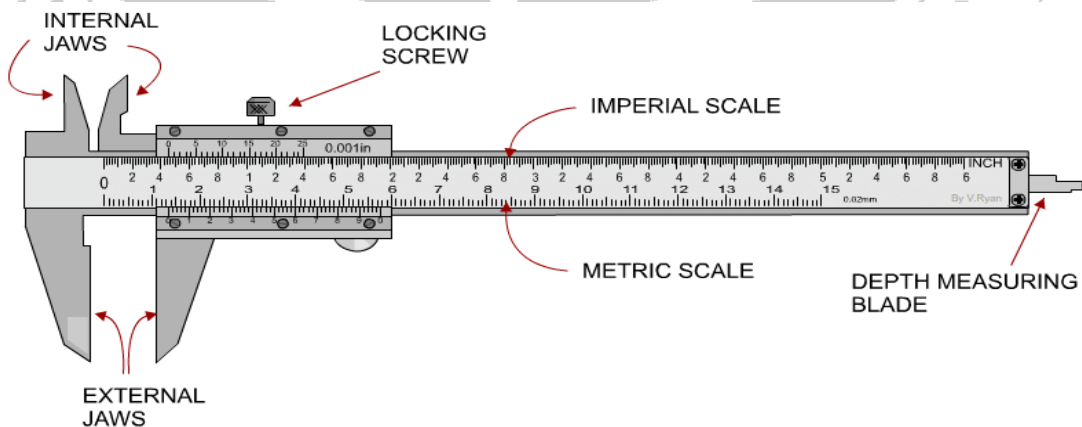
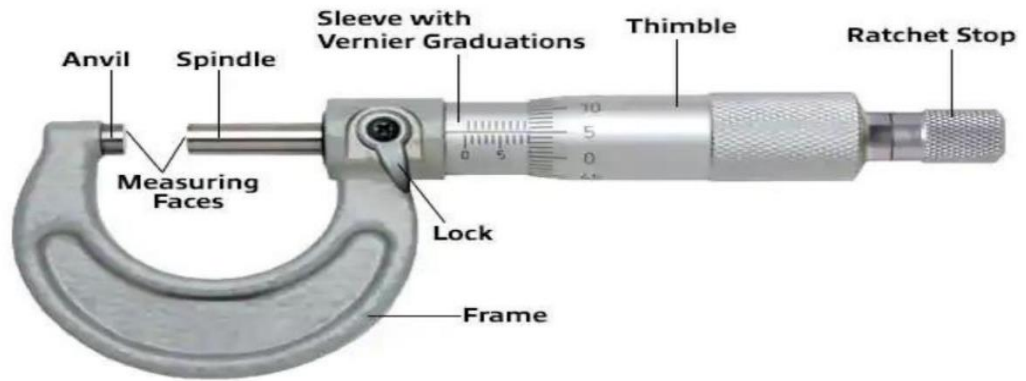


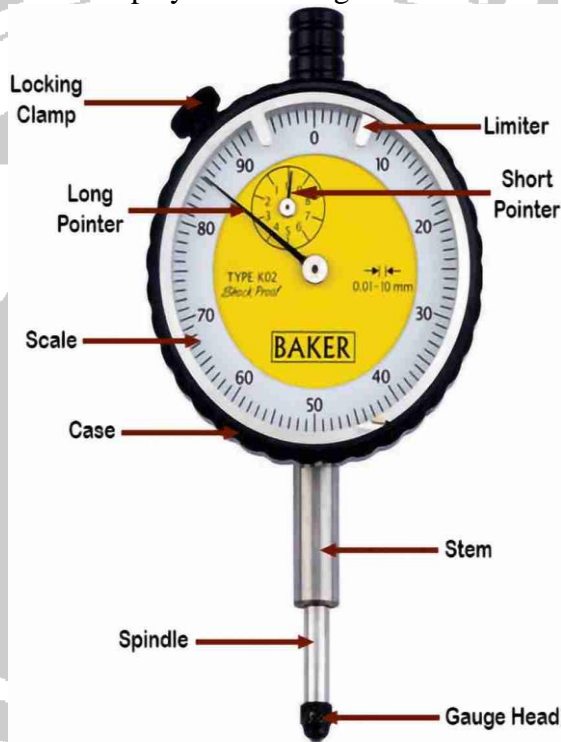
Fig. 2.8 Vernier Calliper

2. **Micrometre:** - Used for measurement of thickness or diameter of the components.



**Fig. 2.9 Micrometre**

**3. Dial Indicator:** Measure the end play of shaft or gears.



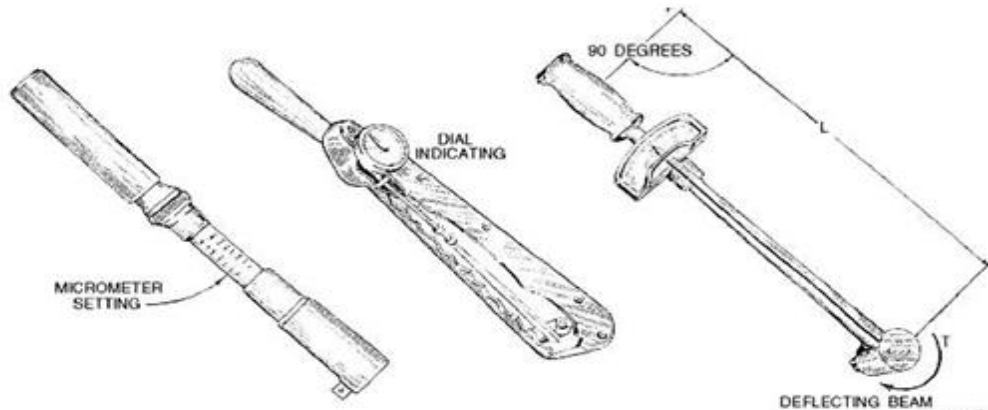
**Fig. 2.10 Dial Indicator**

**4. Thickness gauge /feeler gauge:** To measure the clearance between two parts.



**Fig. 2.11 Feeler gauge**

- c) **Special Tools:** In the automotive industry tools designed for specific tasks in vehicle repair, maintenance or servicing.
1. **Torque wrench:** A torque wrench is a specialized tool used to apply a specific amount of twisting force (torque) to a fastener, such as a bolt or nut.



**Fig. 2.12 Torque Wrench**

2. **Stud extractor :** A stud extractor is a specialized tool used to remove broken or seized studs from threaded holes, typically in engine blocks, exhaust manifold or cylinder heads.



**Fig.2.13 Stud extractor**



**Fig.2.14 Stud Remover**

3. **Stud Remover:** Use to remove broken bolts or studs.

## VII. Experimental setup

Teacher shall arrange tools and equipments open for observation. Demonstrate operation of different general tools, special tools and equipments with safety precautions to be taken during use. The student shall be given the opportunity to handle the tools.

**VIII. Required Resources /Apparatus/Equipments with specification**

Sr. No.	Name of Resource	Suggested Broad Specification	Quantity
1.	General tools	Open end spanner set, Ring Spanner set, Socket spanner set, Hammer and Mallet set, Pliers, screw drivers, Alien Key set.	1 No.
2.	Measuring tools and gauges	Vernier Caliper, Micrometer, Feeler/Thickness gauge, Dial Indicator.	1 No.
3.	Special Purpose tools	Torque Gauge, Stud remover, Stud extractor.	1 No.

**IX. Precautions to be followed**

1. Select the proper tools according to job requirement.
2. Take safety precautions while handling the tools.
3. Handle measuring instruments and devices carefully.

**X. Procedure**

1. Identify the given tools and equipments.
2. Categorize the tools and equipments according to their use and type.
3. Refer the service manuals whenever required.
4. List the safety precautions to be taken while handling given tools.

**XI. Observations**

Student shall observe various tools and equipments of each category note their function, applications and precautions to be taken while using them and record the information in the observation table.

Sr. No.	Name of Tool	Function	Application	Precautions taken while using
1.	Open End Spanner	To open the bolts and Nuts	Where accessibility is good	Proper Size Should be selected which fits snugly against the bolt or nut to avoid slipping making injury to the person.
2.	Ring Spanner			
3.	Box Spanner			
4.	Plier			

Sr. No.	Name of Tool	Function	Application	Precautions taken while using
5.	Hammer			
6.	Feeler Gauge			
7.	Vernier Caliper			
8.	Micrometer			
9.	Torque Wrench			
10.	Piston Ring Compressor			

**XII. Results**

-----

-----

-----

-----

**XIII. Interpretation of Results**

-----

-----

-----

-----

-----

**XIV. Conclusions and Recommendation**

-----

-----

-----

-----

-----

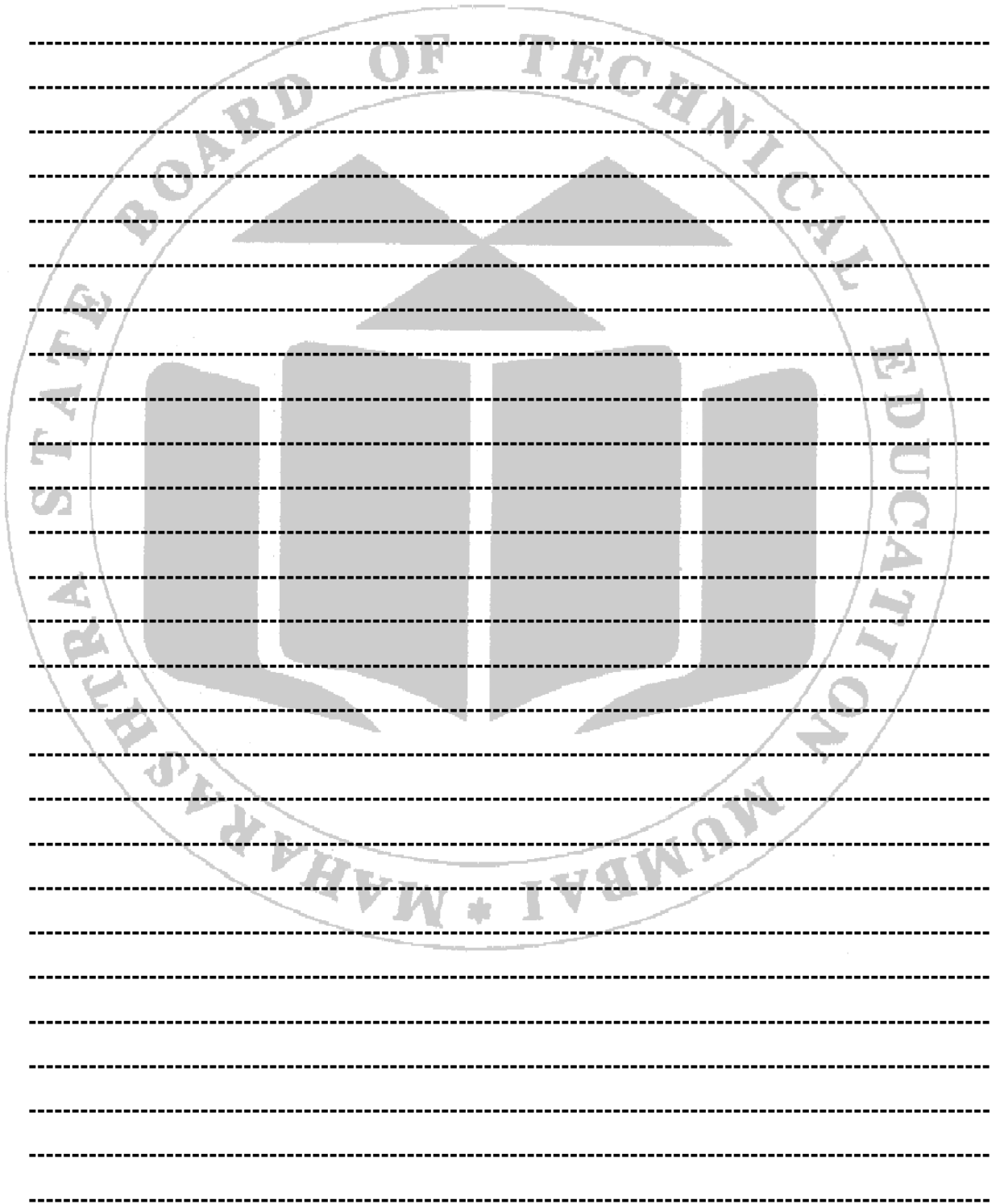
**XV. Practical Related Questions**

*Note: Below given are few sample questions for reference. Teachers must design more such questions so as to ensure the achievement of identified CO.*

1. Enlist the sizes of open end spanner used by you in laboratory.

2. List the number of sockets, number of ratchets and number of extension rods in the socket spanner set.
3. Describe specification of Vernier caliper and Micrometer used by you in laboratory.
4. Enlist the tools and equipments used in laboratory.
5. State the importance of using a torque wrench over a regular spanner in vehicle maintenance and justify your answer with technical reasoning.

**[Space for Answer]**

The image shows a large, faint watermark of the Maharashtra State Board of Technical Education logo. The logo is circular and contains the text "STATE BOARD OF TECHNICAL EDUCATION" at the top and "MAHARASHTRA \* MUMBAI \*" at the bottom. In the center of the logo is a stylized emblem featuring a book and a lamp. The entire page is filled with horizontal dashed lines, providing a space for the student to write their answers to the questions listed above.

-----

-----

-----

-----

-----

-----

-----

-----

-----

-----

**XVI. References / Suggestions for Further Reading**

1. <https://www.youtube.com/watch?v=a0HiHcdp-9w>
2. <https://www.youtube.com/watch?v=QQQqUmug8bQ>
3. <https://www.youtube.com/watch?v=dUXeJN641fw>
4. <https://www.youtube.com/watch?v=ls7pbCuLh1Y>

**XVII. Rubrics for Assessment Scheme**

<b>Performance Indicators</b>		<b>Weightage</b>
<b>Process Related (15 Marks)</b>		<b>(60%)</b>
1	Preparation of Practical set up, Safety measures and standard practices	20%
2	Handling of service tools carefully while performing the practical	20%
3	Identify the probable Causes of the Troubles ,Inspection, Record Keeping, Reassembly	20%
<b>Product Related (10 Marks)</b>		<b>(40%)</b>
4	Interpretation of result	20%
5	Conclusions	10%
6	Practical related questions	10%
<b>Total</b>		<b>100 %</b>

<b>Marks Obtained</b>			<b>Dated signature of Teacher</b>
<b>Process Related (15)</b>	<b>Product Related (10)</b>	<b>Total (25)</b>	

**Practical No: 03: \* Dismantling and Assembling of Clutch.****I. Practical Significance**

This practical helps student to understand the internal mechanism of the clutch system and gain hands-on skills in dismantling, inspecting and assembling clutch components, which is critical in real-world vehicle servicing.

**II. Industry/Employer Expected Outcome(s)**

This practical is expected to develop the following skills for the industry/Employer.

1. Ability to dismantle and reassemble clutch assemblies correctly.
2. Identify faults in clutch components and suggest repairs or replacements.
3. Ensure proper torque and alignment during assembly to avoid clutch failure.

**III. Course Level Learning Outcome (CO)**

CO2- Carryout repairing activities by following laid down procedures.

**IV. Laboratory Learning Outcome(s)**

1. Dismantle given clutch.
2. Identify components of clutch.
3. Draw any components of the clutch.
4. Identify fault in clutch.
5. Assemble clutch.

**V. Relative Affective Domain Related Outcome(s)**

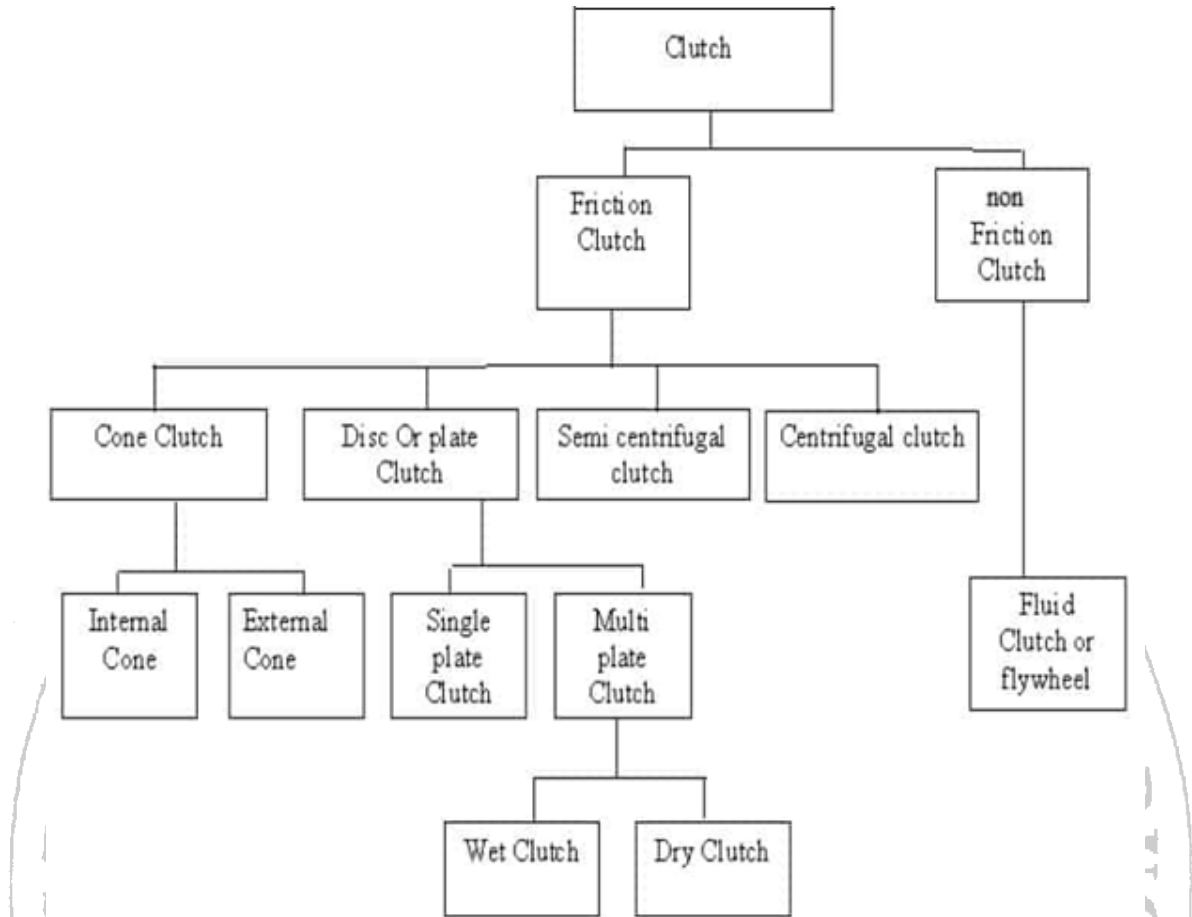
1. Demonstrate responsibility in tool handling and safe practices.
2. Show attention to detail during inspection and assembly.
3. Collaborate effectively in a team during workshop activities.

**VI. Minimum Theoretical Background with diagram**

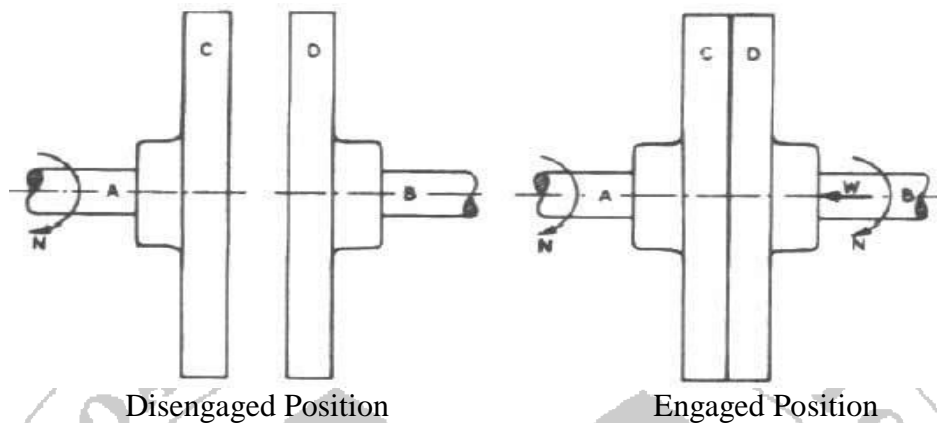
A clutch is a mechanical device used in vehicles and machinery to engage or disengage power transmission between two rotating components.

**Function:**

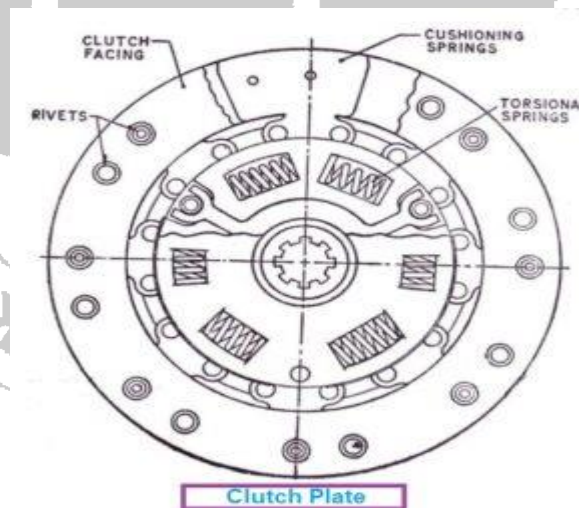
1. Transmitting the torque from the engine to the drivetrain.
2. Smoothly deliver the power from the engine to enable smooth vehicle movement.
3. Perform quietly and to reduce drive-related vibration.
4. Protect the drivetrain when given the inappropriate use.

**Types of clutches:****Fig.3.1 Types of Clutch****Working Principle:**

It works on the principle of friction. When two frictional surfaces which are apart from each other (out of which one is rotating and one is stationary) are brought in contact by applying external force, there exists a friction between them due to which stationary surface starts to rotate along with rotating one. The friction between the two surfaces depends upon area of the frictional surfaces, coefficient of friction and axial pressure upon them.

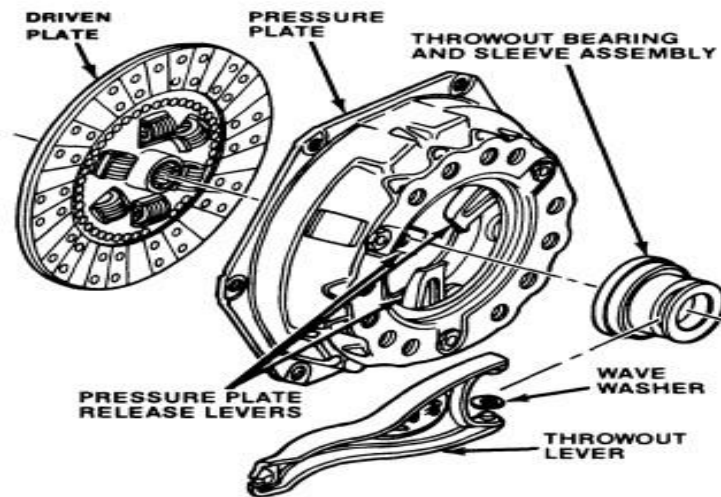
**Diagram:****Fig.3.2 working principle****Components of clutch:****A) Single Plate Coil Spring and diaphragm type:****1. Clutch Plate (Friction Plate):**

It is also known as friction plate, is a key part of vehicle's clutch system. It connects and disconnects the engine from the transmission enabling smooth gear shifts. This component is a thin, disc-shaped metal plate with friction linings on both sides. These linings allow it to grip the flywheel and pressure plate, transmitting power when engaged and separating them when disengaged.

**Fig.3.3 Clutch Plate**

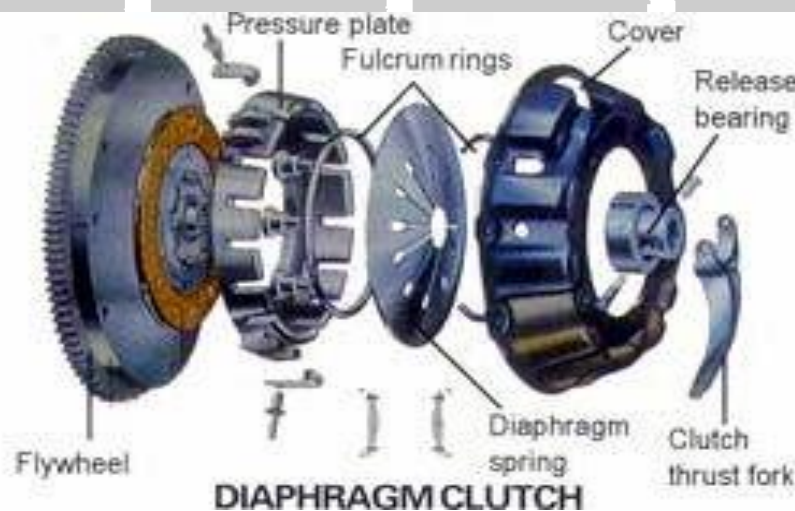
**2. Pressure Plate Assembly:** The pressure plate is one of the most important components in a clutch assembly. It applies clamping force to hold the friction disc tightly between itself and the flywheel, allowing power to be transmitted from the engine to the transmission. The pressure plate is bolted to the flywheel, and both rotate together during operation. Clutch cover forms the housing for the other clutch components like release lever, axial springs, anti-rattle springs. Holes are provided for heat

dissipation. Release levers enable the driver to disengage the clutch by releasing the clamping force on the clutch plate.



**Fig.3.4 Pressure Plate Assembly**

- 3). **Throw-out bearing:** It transfers the force at the pedal from the stationary. Linkages to the rotating clutch.
- 4). **Diaphragm Spring:** A diaphragm spring, also known as a clutch diaphragm spring, is a type of a disc spring used in automotive clutches to generate the pressure needed for clutch engagement. It's essentially a shallow, conical spring that acts as a pressure plate, using its own elasticity to engage and disengage the clutch



**Fig.3.5 Diaphragm Spring**

**Working of Single Plate Coil Spring Type:** When an engine starts running, the pressure plate also rotates as it is connected to the flywheel. Once the driving force is pushed, the clutch releases itself. The pressure plate moves away from the friction disc due to this motion. Then, this friction plate is released, causing disengagement of this clutch.

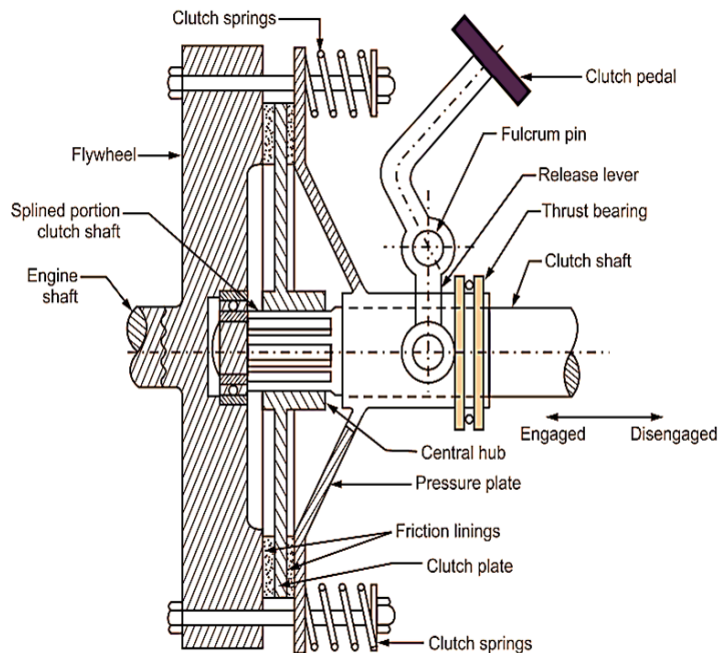


Fig.3.6 Single Plate Coil Spring Clutch

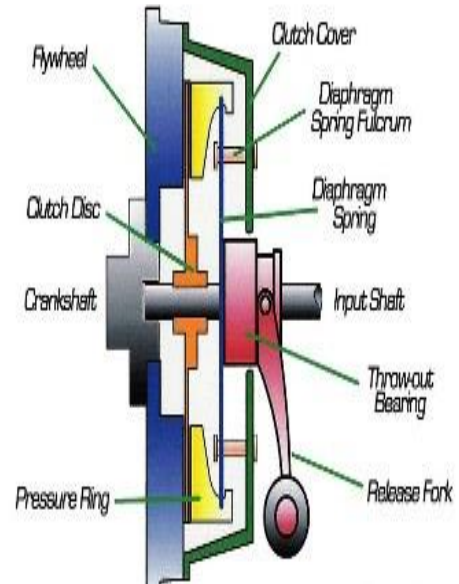


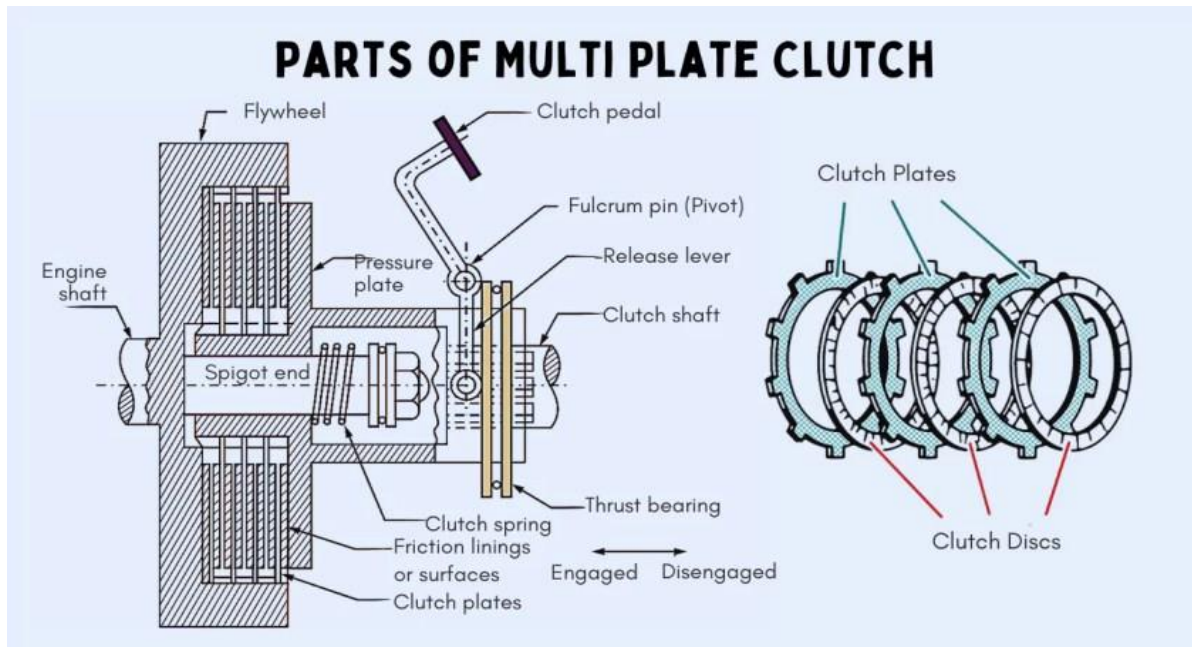
Fig.3.7 Single Plate Diaphragm Clutch

### B) Multi-plate Clutch:

**Construction:** Multi-plate Clutch Consists of a number of clutch plates. The plates are alternatively fitted to the engine shaft and gear box shaft. One set of plates slides in grooves on the flywheel and the other set slides on splines of pressure plate hub. They are firmly pressed by strong coil springs and assembled in a drum. Each Alternate plate has inner and outer splines.

**Working:** When the clutch pedal is pressed clutch springs are compresses and the friction plate move away from the clutch disc. Due to this the contact between the metal plates and friction plates is disconnected and the clutch is disengaged.

When the clutch pedal is released the clutch springs expand and forces the pressure plates on the friction plate. Due to the contact between the metal plates and friction plates the torque is transmitted and the clutch is engaged.



**Fig.3.8 Multi-plate Clutch**

**Materials Used for Clutch friction lining: -**

Asbestos, Cork, Ferodo, Leather, Fabric

**VII. Experimental setup**



**Fig..3.9 Working Model of Single Plate Clutch Fig. 3.10 Multi-plate Clutch Assembly**

**VIII. Required Resources /Apparatus/Equipment with specification**

Sr. No.	Name of Resource	Suggested Broad Specification	Quantity	Remarks
1.	Demonstration working model of Single plate dry clutch	Single plate dry coil spring type/ Diaphragm type clutch used in car/light motor vehicle/Heavy motor vehicle	02 No.	

Sr. No.	Name of Resource	Suggested Broad Specification	Quantity	Remarks
2.	Demonstration working model of Multi-plate clutch	Multi-plate Wet clutch used motorcycles	02 No.	
3.	Basic hand tools	Open end spanner set, Ring spanner set, Socket spanner, Ball pin Hammer, Plier and screw driver.	01 No.	
4.	Measuring tools and Gauges	Vernier Caliper, Micrometer, screw gauge, Feller gauge	01 No.	
5.	Clutch spring Compressor	Clutch spring Compressor: SST- Include a crossbar for removing rear case clutch springs.	01 No.	

**IX. Precautions to be followed**

1. Select proper hand tools and measuring devices.
2. Do not use damaged tools.
3. Refer the service manual to carry out dismantling and assembly procedure.
4. Handle measuring instruments and devices carefully.
5. Ensure all parts are properly aligned before tightening bolts.

**X. Procedure: Dismantling the Single plate clutch assembly-**

1. Remove the clutch assembly from demonstration model.
2. Place the clutch assemblies on the arbor press with wooden block across the cover apply pressure with the press or clutch spring compressor to compress the springs.
3. Loosen the lock nuts while holding the eye bolt with screw driver.
4. Remove all the lock nuts and eye bolts to take out the parts.
5. Sketch the clutch plate and components of pressure plate assembly.

**Assembling the Single plate clutch -**

Inspect all the components for good condition before assembly and then proceed-

1. Keep the pressure plate inverted and place the pressure/thrust springs on it in a vertical position seating them on their locating bosses.
2. Assemble the release levers, eyebolts and pin, lay the cover over the parts keeping the springs in position.
3. Place the wooden block across the cover and apply pressure with the press or clutch spring compressor to compress the springs, at the same time guiding the eyebolts and pressure plate lugs through the correct holes in the cover.
4. Make sure that the thrust springs are seated properly.
5. Tighten the lock nuts while holding the eye bolt with screw driver.
6. Mount the clutch plate and pressure plate assembly on the stand.
7. Clutch the operation of clutch for engagement and disengagement.

### Dismantling the Multi-plate clutch assembly

1. Remove the transmission: Disconnect the clutch actuation, gear selector linkage and electrical connections from the transmission.
2. Remove the clutch assembly:
  - Disconnect the pressure plate from the flywheel.
  - Remove the clutch discs, alternating friction and steel plates
3. Inspect the components: Check for wear and tear on the flywheel, pressure plate, clutch discs.
4. Clean and prepare the surfaces: Clean the flywheel and clutch housing surfaces.

### Assembling the Multi-plate clutch assembly


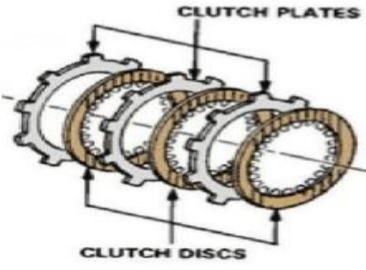
1. Install the flywheel: If resurfacing was needed, ensure the flywheel is properly machined and Clean.
2. Install the pressure plate: Align and tighten the pressure plate bolts to the specified torque, using thread locker if needed.
3. Install the clutch discs: Stack the friction and steel plates in the correct order, ensuring proper alignment and engagement.
4. Install the pilot bearing: Ensure the pilot bearing is correctly installed in the crankshaft, supporting the transmission input shaft.
5. Reinstall the transmission: Connect the clutch actuation, gear selector linkage, and electrical connections.
6. Final Adjustments: Adjust the clutch pedal or cable to ensure proper clutch engagement and disengagement.

## XI. Observations:

### i. Measurement of dimension

Sr. No.	Name of component	Readings in mm	
		Single Plate Clutch	Multi-plate clutch
1.	Clutch friction lining thickness		
2.	Thickness of pressure plate		
3.	Clutch spring free height		
4.	Clutch Spring seated height		
5.	Clutch plate flatness		
6.	Axial Clearance during assembly (Plate to Plate)		

**ii. Components of Clutch**

Sr. No.	Name of components	Location in clutch assembly	Figure	
			Single Plate	Multi-plate clutch
1.	Clutch Plate	Single plate in one system, multiple plates alternately stacked in another		
2.	Pressure plate			
3.	Diaphragm Spring/Clutch Spring			
4.	Bearing			

**XII. Results**

-----

-----

-----

-----

-----

-----

**XIII. Interpretation of Results**

-----  
-----  
-----  
-----  
-----

**XIV. Conclusions and Recommendation**

-----  
-----  
-----  
-----  
-----

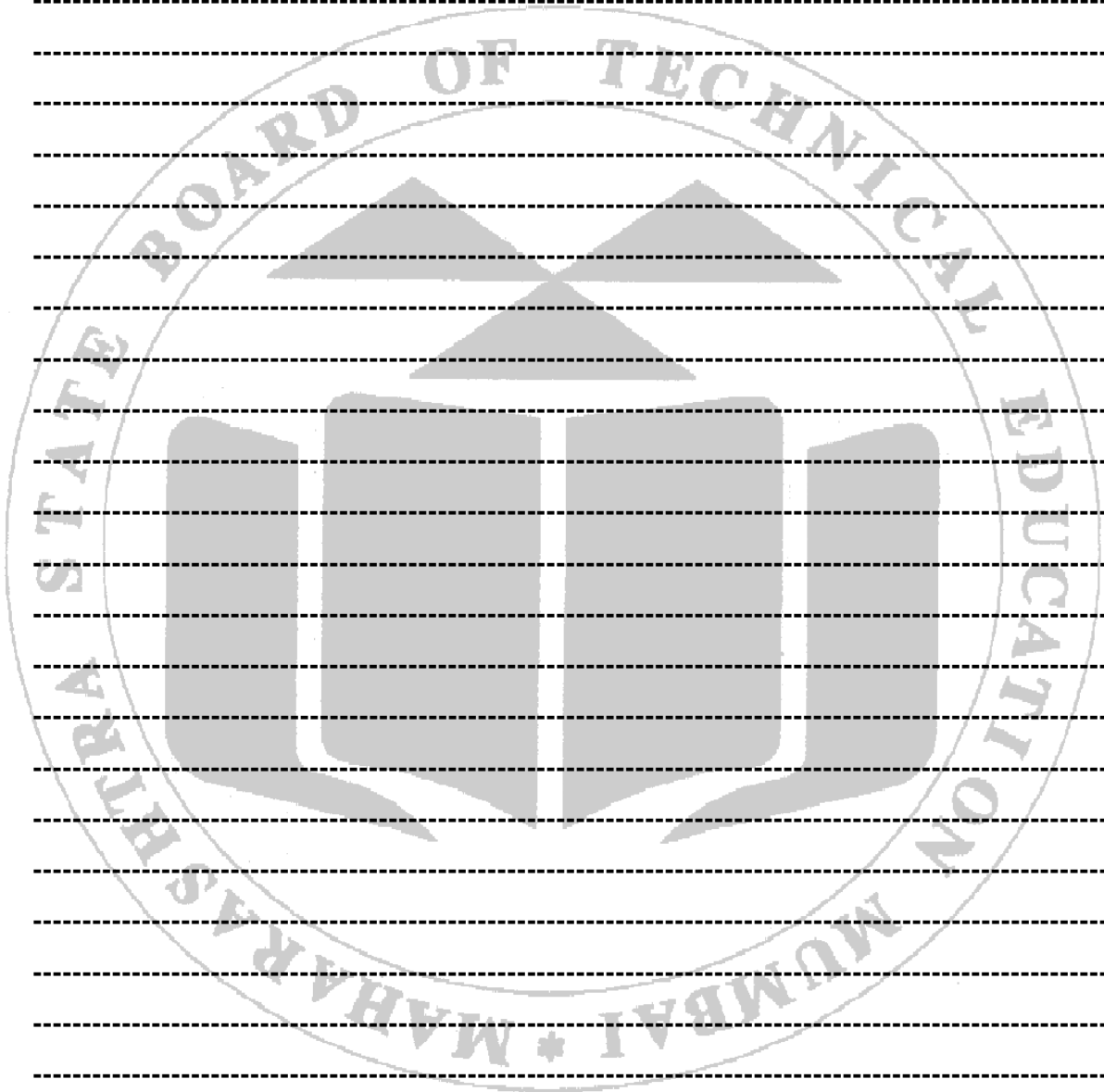
**XV. Practical Related Questions**

*Note: Below given are few sample questions for reference. Teachers must design more such questions so as to ensure the achievement of identified CO.*

1. Enlist the components of Single plate and Multi-plate clutch assembly.
2. Compare between Single plate clutch with Multi-plate clutch on the basis of following parameters a) Number of Plates b) Friction surfaces c) Size & Weight d) Applications.
3. Identify and label the components between which the friction plate is placed during the clutch assembly process.
4. State the types of clutch friction lining materials and their coefficients of friction.
5. List the number of friction and pressure plates found in the dismantled multi-plate clutch.
6. Draw a neat, labeled diagram of any one clutch component. (e.g. pressure plate or friction Plate).
7. List two common faults found in clutches and explain how you would identify them during inspection.

[Space for Answer]

-----  
-----  
-----  
-----  
-----  
-----  
-----



**XVI. References / Suggestions for Further Reading**

1. <https://www.youtube.com/watch?v=devo3kdSPQY>
2. <https://www.youtube.com/watch?v=MrAq064wqUg>
3. <https://www.youtube.com/watch?v=TcYsV063lk8>
4. <https://www.youtube.com/watch?v=QcWELyTbdP4>
5. <https://www.youtube.com/watch?v=SxuwI3PnivM>

**XVII. Rubrics for Assessment Scheme**

<b>Performance Indicators</b>		<b>Weightage</b>
<b>Process Related (15 Marks)</b>		<b>(60%)</b>
1	Preparation of Practical set up, Safety measures and standard practices	20%
2	Handling of service tools carefully while performing the practical.	20%
3	Identify the probable Causes of the Troubles ,Inspection, Record Keeping, Reassembly	20%
<b>Product Related (10 Marks)</b>		<b>(40%)</b>
4	Interpretation of result	20%
5	Conclusions	10%
6	Practical related questions	10%
<b>Total</b>		<b>100 %</b>

<b>Marks Obtained</b>			<b>Dated signature of Teacher</b>
<b>Process Related (15)</b>	<b>Product Related (10)</b>	<b>Total (25)</b>	

**Practical No: 04: Dismantling and Assembling Gear Box.****I. Practical Significance**

The gearbox is a part of the transmission system placed between the clutch and propeller shaft. It changes the torque from the engine to the wheels and allows neutral and reverse gear. Now a day, in most of the automobiles synchromesh gear box is used for power transmission purpose. Hence it is significant to understand the constructional details of synchromesh gear box and demonstrate its working for troubleshooting purpose. In this practical we use actual working unit or cut-section working model of synchromesh gear box for dismantling purpose.

**II. Industry/Employer Expected Outcome(s)**

This practical is expected to develop the following skills for the industry/Employer,

1. Ability to dismantle and reassemble a manual transmission gearbox accurately.
2. Identify, inspect and interpret gear mechanism components (e.g., gears, shafts, synchronizers).
3. Demonstrate competence in fault diagnosis and basic repair of gearbox components.

**III. Course Level Learning Outcome (CO)**

CO2- Carryout repairing activities by following laid down procedures.

**IV. Laboratory Learning Outcome(s)**

1. Dismantle gear box.
2. Identify various components of Synchromesh Gear Box.
3. Inspect components of gear box.
4. Identify fault in gear box.
5. Assemble gear box.

**V. Relative Affective Domain Related Outcome(s)**

1. Follow safety practices.
2. Demonstrate working as a leader/a team member.
3. Maintain tools and equipments.
4. Follow ethical practice.

**VI. Minimum Theoretical Background with diagram**

Gear box is located between clutch and propeller shaft in transmission line on the chassis frame. It performs the following functions.

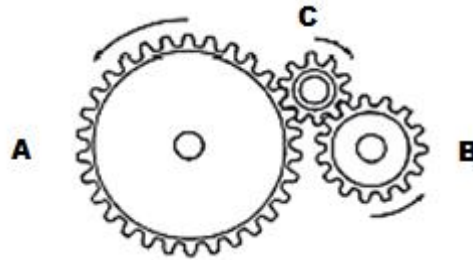
1. It allows the vehicle to stay in neutral, so the engine and wheels are not connected, even if the clutch is engaged.
2. It changes the torque between the engine and wheels as needed for different driving conditions.

**Types of Gear Box:**

1. Sliding Mesh Gearbox – Oldest type, uses sliding gears for engagement.
2. Constant Mesh Gearbox – Gears are always in mesh; dog clutches are used for engagement.
3. Synchromesh Gearbox – Similar to constant mesh but with synchronizers for smooth shifting.

**Working Principle of Gear Box:**

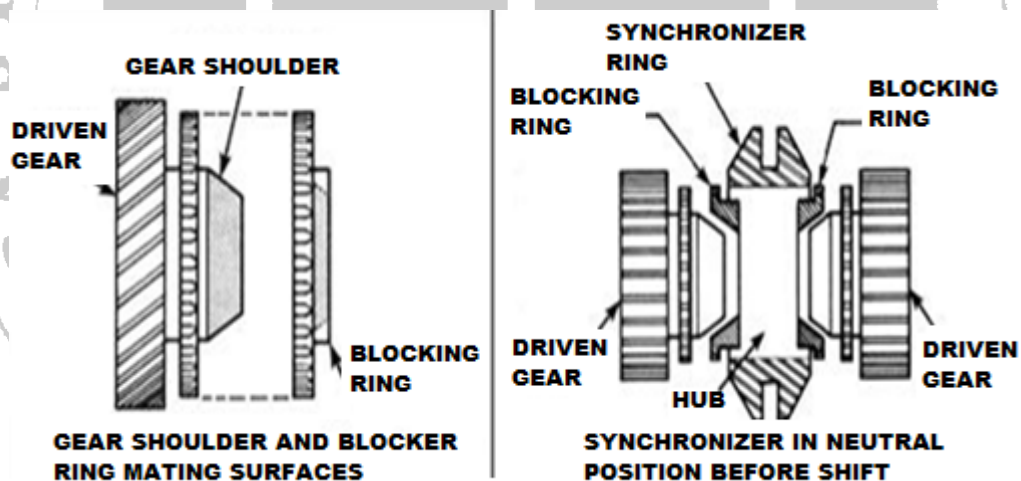
The figure shows three gears: A, B and C. Gears A and B are large and both rotate counterclockwise because a central gear between them reverses the rotation direction. Gear C is smaller and rotates clockwise.



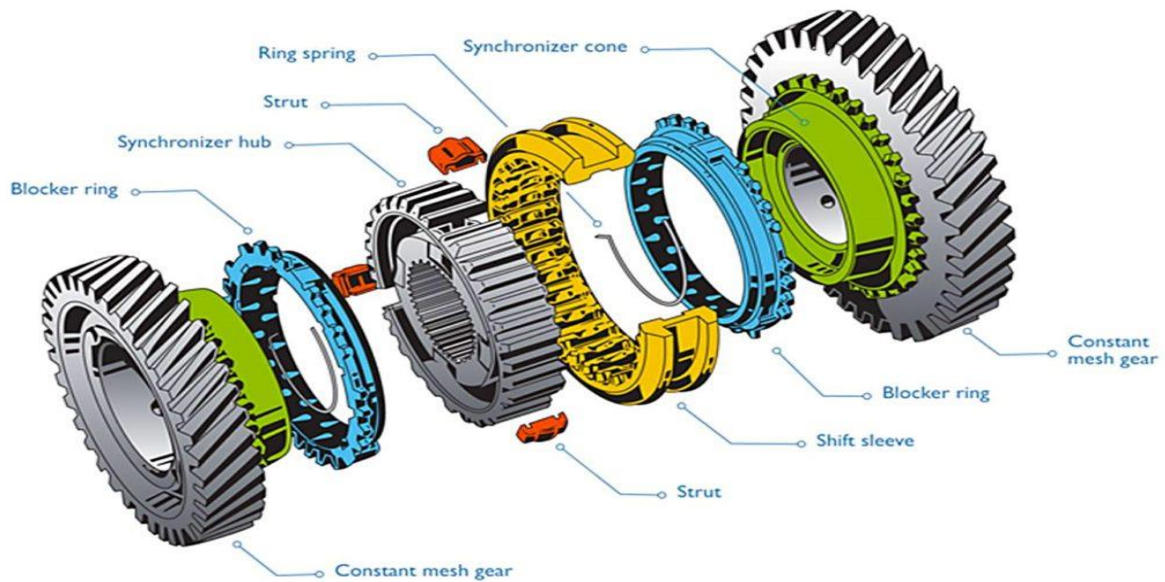
**Fig.4.1 Principle of gearing**

**Synchromesh Gear Box:**

In a synchromesh gearbox, the synchromesh device matches the speed of two gears before they engage, so double clutching is not needed. When a vehicle is moving and the gear is in neutral, the gears still rotate, but not at the same speed. If two gears with different speeds are forced to engage, it causes noise and makes shifting difficult. The synchromesh device helps avoid these problem by synchronizing the gear speeds for smooth and easy shifting.

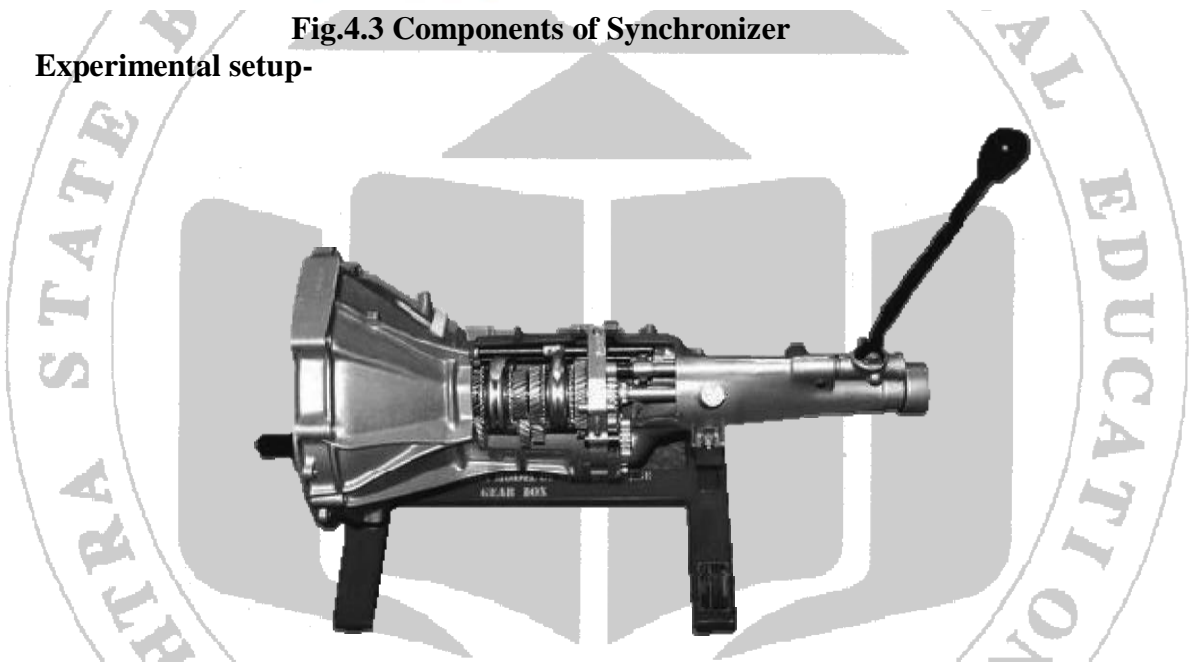


**Fig.4.2 Synchronizer Device**



**Fig.4.3 Components of Synchronizer**

**VII. Experimental setup-**



**Fig.4.4 Working Model of Synchromesh Gear box**

**VIII. Required Resources /Apparatus/Equipment with specification**

Sr. No.	Name of Resource	Specification	Quantity	Remarks
1.	Cut-section working model/Actual unit of Synchromesh gear box	Manual 4/5-speed synchromesh gearbox used in car/light /Heavy motor vehicle	02 No.	
2.	Basic tools	Open end spanner set, Ring spanner set, Socket spanner set,	01 No.	

Sr. No.	Name of Resource	Specification	Quantity	Remarks
		Ball pin Hammer, Plier and Screw driver set		
3.	Measuring tools and Gauges	Vernier Caliper/Micrometer screw gauge, Feeler gauge	01 No.	
4.	Torque wrench	Torque wrench with square drive and scale	01 No.	
5.	Pullers	Two-arm puller, Ball bearing extractor	01 No.	

### IX. Precautions to be followed

1. Select proper hand tools and measuring devices.
2. Refer the service manual to carry out dismantling.
3. Handle measuring instruments and devices carefully.
4. Apply specific torques wherever required.
5. Do not use excessive force to remove or install component.
6. Handle synchronizer and bearings carefully to avoid damage.

### X. Procedure: Dismantling the synchromesh gear box:

1. Preparation and safety.
  - a. Ensure the power source (if electric) is disconnected.
  - b. Keep necessary tools ready: spanners, screw drivers, pullers, tray and cloth.
  - c. Wear proper personal protective equipment (safety gloves, goggles).
2. Remove the Gearbox Housing.
  - a. Unscrew bolts and remove the top and side cover carefully.
  - b. Place bolts and washer in a labeled tray for reassembly.
3. Dismantle Gear Shift Mechanism.
  - a. Remove the gear lever, selector rods and selector forks.
  - b. Note or mark the alignment for correct reinstallation.
4. Remove Shafts and Gear Assemblies.
  - a. carefully take out:
    - i. Input shaft
    - ii. Counter shaft
    - iii. Output shaft
  - b. Remove gears, synchronizer hubs, sleeves, rings and bearings.
  - c. Arrange parts in sequence on a clean cloth or tray.
5. Clean and Inspect Components.
  - a. Wipe off grease and dirt using a cloth.
  - b. Visually inspect parts for wear, scoring or damage.

**Inspection:**

- a. Inspect the transmission case for cracks and worn or damaged bearing bores and threads.
- b. Check each synchronizer sleeve for free movement on its hub.
- c. Check the amount of synchronizer ring wear by placing the ring on its gear cone.
- d. Inspect the shift fork and groove in the synchronizer sleeve for wear or damage.
- e. Check all bushing and bearings.
- f. Inspect all gears for crack or worn out excessively.

**Assembling the synchromesh gear box:**

1. Reinstall Shafts and Gears.
  - a. Place the Input, Counter and Output shafts in their respective bearings/mounts.
  - b. Fit gears, synchronizer hubs, rings and sleeves in the correct order.
2. Reassemble Synchronizer Mechanisms.  
Install synchronizer rings and hubs aligned properly to ensure smooth gear engagement.
3. Fit Gear Selector Forks and Shift Rods.
  - a. Reinsert selector rods and forks into sleeves.
  - b. Ensure correct alignment with gear shift mechanism.
4. Reassemble Gearbox Housing
  - a. Clean gasket surfaces and install new gasket (if available)
  - b. Place the cover back and tighten bolts using proper torque.
5. Function Check
  - a. Manually shift through all gears to ensure proper engagement.
  - b. If the model is motorized, reconnect power and perform a slow test run to observe gear shifts and operation.

**XI. Observations Table-**

- a) Note: Identify the driver and driven gears for different gears for different gear ratios after assembling and count the number of teeth on respective gears. Verify the gear ratio calculated during dismantling.

**i. Measurement of dimension**

Sr. No.	Gear Selected	No of teeth on		Gear Ratio Obtained
		Driven gear	Driver gear	
1	First			
2	Second			
3	Third			
4	Forth			
5	Fifth			
6	Reverse			

**ii. Condition and Observation**

Sr. No.	Components	Condition(Ok /Damaged)	Observation	Remark
1.	Input Shaft	Ok	Rotates freely	
2.	Gears			
3.	Synchronizer Ring			
4.	Bearing			
5.	Gear Selector Fork			

**XII. Results**

**Gear ratio obtained for-**

1. First gear = .....
2. Second gear = .....
3. Third gear = .....
4. Fourth gear = .....
5. Fifth gear = .....
6. Reverse gear = .....

**XIII. Interpretation of Results**

-----

-----

-----

-----

-----

**XIV. Conclusions and Recommendation**

-----

-----

-----

-----

-----

-----

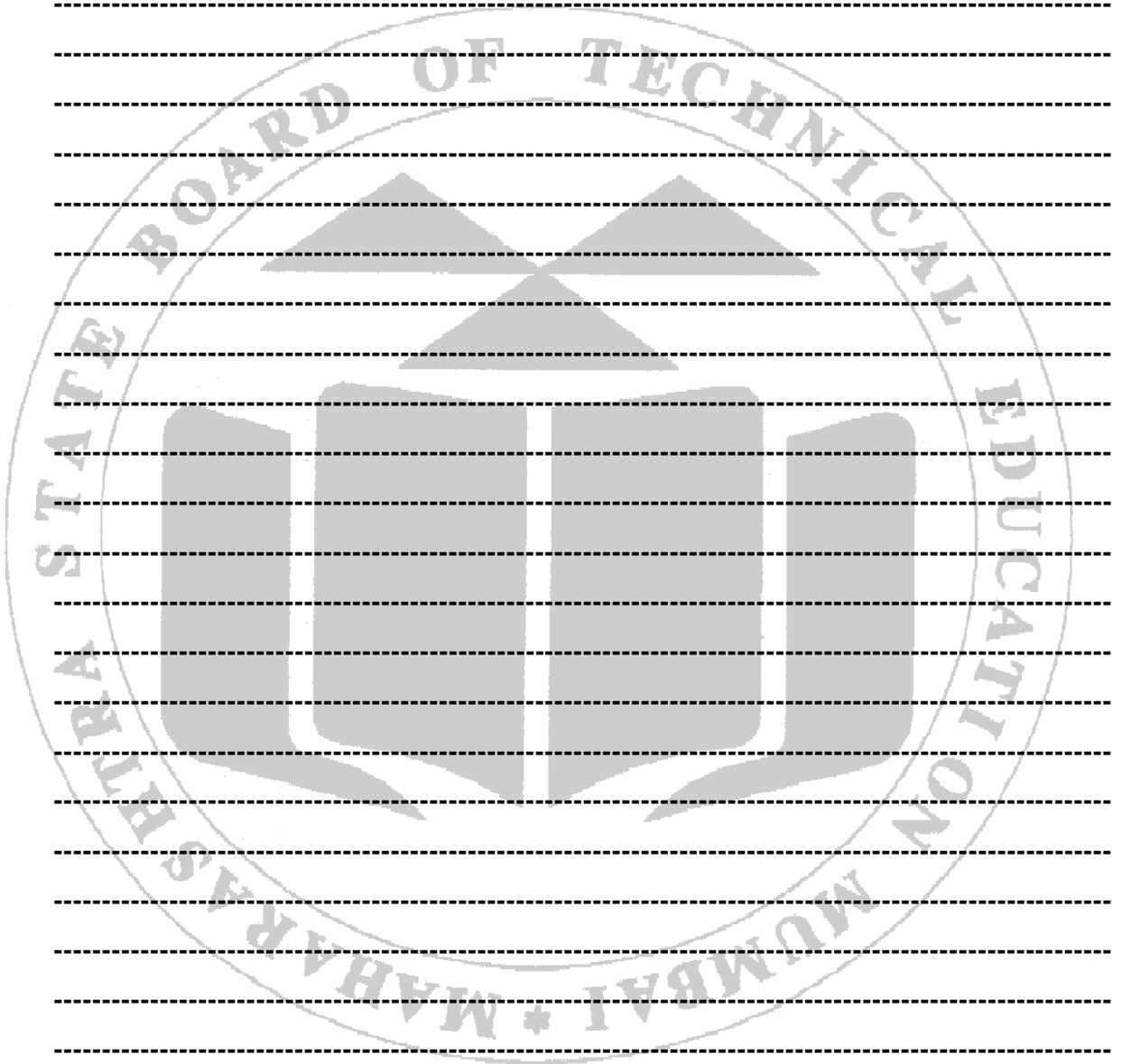
**XV. Practical Related Questions**

*Note: Below given are few sample questions for reference. Teachers must design more such questions so as to ensure the achievement of identified CO.*

1. List the major components of dismantled gear box.
2. State the types of gears present in the dismantled gear box.
3. State the total number of shafts found in the dismantled gear box.
4. Illustrate the method of dismantling a Synchromesh Gear box using appropriate tool.
5. Explain how different faults in a gear box can be identified during inspection.

6. Draw a neat and labeled diagram of a 4-speed Synchronesh Gear box.

[Space for Answer]



**XVI. References / Suggestions for Further Reading**

1. <https://www.youtube.com/watch?v=wCu9W9xNwtI&t=200s>
2. <https://www.youtube.com/watch?v=nM4CuWlnJY0>
3. <https://www.youtube.com/watch?v=vOo3TLgL0kM>
4. <https://www.youtube.com/watch?v=QjWmGeJwC2I>
5. <https://www.youtube.com/watch?v=L99KP2ASWGs>

**XVII. Rubrics for Assessment Scheme**

<b>Performance Indicators</b>		<b>Weightage</b>
<b>Process Related (15 Marks)</b>		<b>(60%)</b>
1	Preparation of Practical set up, Safety measures and standard practices	20%
2	Handling of service tools carefully while performing the practical.	20%
3	Identify the probable Causes of the Troubles ,Inspection, Record Keeping, Reassembly	20%
<b>Product Related (10 Marks)</b>		<b>(40%)</b>
4	Interpretation of result	20%
5	Conclusions	10%
6	Practical related questions	10%
<b>Total</b>		<b>100 %</b>

<b>Marks Obtained</b>			<b>Dated signature of Teacher</b>
<b>Process Related (15)</b>	<b>Product Related (10)</b>	<b>Total (25)</b>	

**Practical No: 05: Dismantling and Assembling Differential unit.****I. Practical Significance**

The differential is an important part of a vehicle's final drive that lets the wheels turn at different speeds during cornering. In this practical, students learn to dismantle, inspect, and reassemble the differential unit to understand how power is transmitted to the wheels. A working or cut-section model of a rear axle is used for this purpose.

**II. Industry/Employer Expected Outcome(s)**

This practical is expected to develop the following skills for the industry/Employer.

1. Ability to dismantle and reassemble the differential unit properly.
2. Identify and inspect internal components like crown wheel, pinion, and spider gears.
3. Perform fault diagnosis and basic maintenance of the final drive system.

**III. Course Level Learning Outcome (CO)**

CO2- Determine velocity and acceleration for given mechanism.

**IV. Laboratory Learning Outcome(s)**

1. Dismantle differential.
2. Identify the components of differential.
3. Check components of differential.
4. Identify Faults in differential.
5. Assemble differential.

**V. Relative Affective Domain Related Outcome(s)**

1. Follow safety practices.
2. Practice good housekeeping.
3. Demonstrate working as a leader/a team member.
4. Maintain tools and equipment.
5. Follow ethical Practices.

**VI. Minimum Theoretical Background with diagram**

Differential is a gear system between the two driving axles. It lets the wheels turn at different speeds when turning and at the same speed when going straight. Also called the final drive, it uses gears to reduce engine speed and increase torque to the wheels. In front-wheel drive vehicles, it is placed after the gearbox. In rear-wheel drive vehicles, it is located in the rear axle after the propeller shaft.

**Working Principle of Differential:**

The differential works on the principle of allowing the driving wheels to rotate at different speeds while receiving power from the engine.

1. When the vehicle moves straight, both wheels rotate at the same speed, and the differential transmits equal power to both wheels.
2. When the vehicle takes a turn, the outer wheel travels a longer distance and must rotate faster than the inner wheel.

- The differential gears adjust automatically, allowing one wheel to turn faster than the other while still transmitting power.

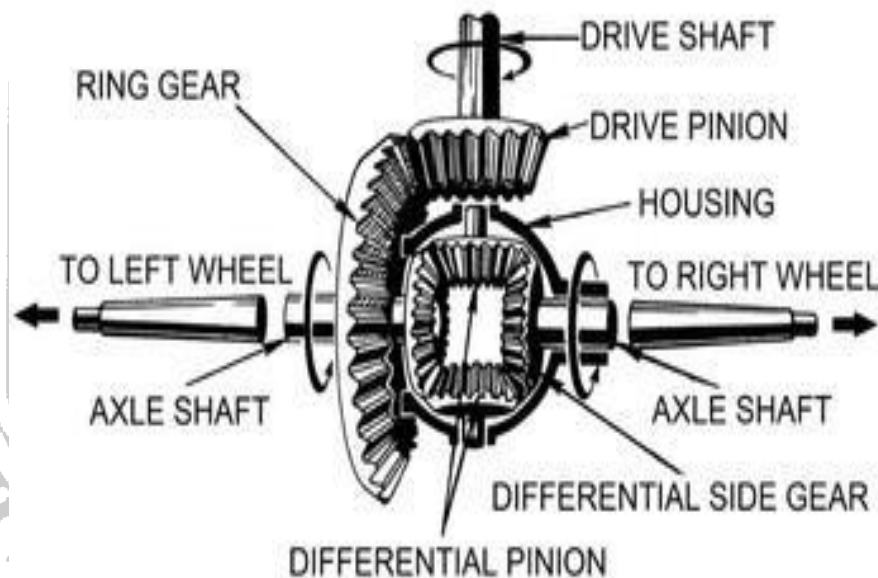
### Constuction and Working of Differential:

The crown wheel is connected to a cage that holds a cross pin with two small planet (or bevel) gears. These planet gears are in mesh with two larger sun gears, which are connected to the left and right axle shafts.

- When the vehicle moves straight, the cage and all the gears inside it rotate together, and both axle shafts (and wheels) turn at the same speed.
- When the vehicle turns, the cage slows down, and the planet gears rotate between the sun gears, allowing one wheel (outer) to rotate faster than the other (inner).
- This action lets the outer wheel cover more distance during the turn without slipping or dragging.

So, the differential allows power to be transmitted to both wheels while letting them rotate at different speeds when needed, especially during cornering.

### VII. Experimental setup



**Fig.5.1 Differential Assembly**

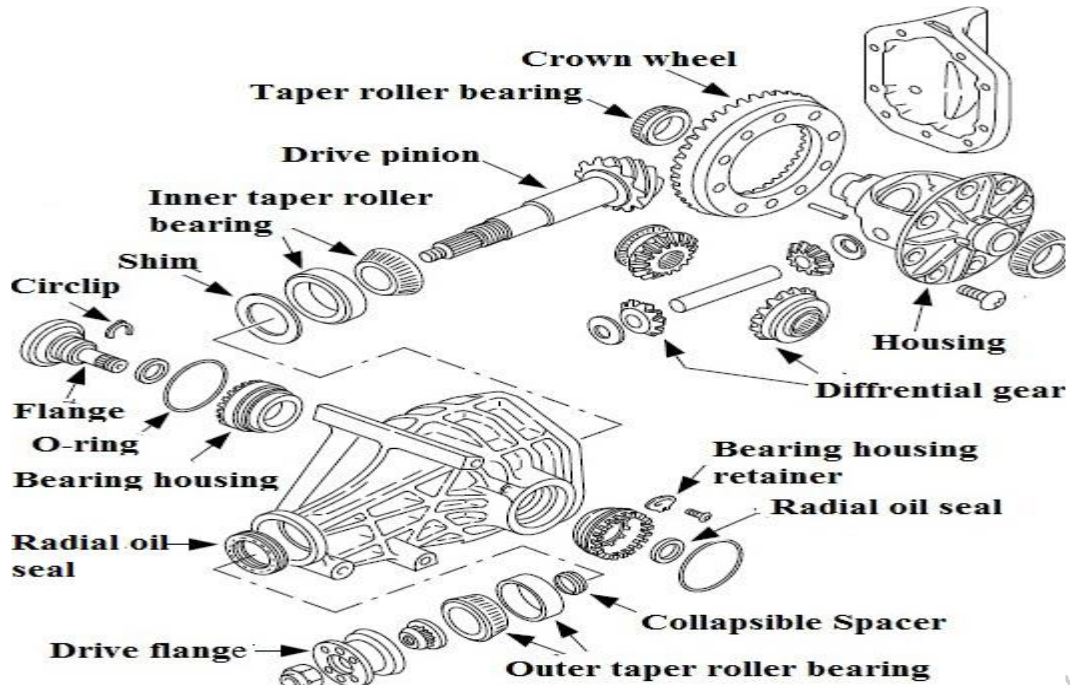


Fig.5.2 Exploded view of Differential assembly

**VIII. Required Resources /Apparatus/Equipment with specification**

Sr. No.	Name of Resource	Specification	Quantity	Remarks
1	Cut-section working model/Actual unit of Differential Assembly	Open type differential Assembly	01 No.	
2	General Tools	Spanners, Hammer, Pliers, Screw Drivers, Tool box	01 No.	
3	Measuring Tools	Feeler Gauge, Dial indicator with magnetic stand	01 No.	
4	Special Tools	Torque wrench, puller	01 No.	

**IX. Precautions to be followed**

1. Select proper hand tools and measuring devices.
2. Refer the service manual to carry out dismantling.
3. Apply specific torques whenever required.

**X. Procedure: Dismantling of differential**

1. Remove the differential from axle housing.
  - Disconnect axle shafts.
  - Unscrew and remove differential housing bolts.
  - Carefully lift the differential unit out.
2. Remove the ring gear.

- Unscrew the ring gear bolts.
  - Gently tap off the ring gear from the differential case.
3. Remove the carrier.
    - Remove the carrier cap bolts.
    - Take out the carrier from the housing.
  4. Remove the pinion gear.
    - Unscrew and remove the pinion nut, crush washer, and bearing cap.
    - Take out the pinion gear carefully.
  5. Disassemble internal gears.
    - Remove side gears, spider gears, and clutch packs from the carrier.
  6. Clean.
    - Clean all parts using solvent or degreaser.
    - Inspect gears, bearings, and housing for wear or damage.
    - Replace faulty or worn parts.

**Inspection:**

1. Inspect each tooth for any pitting or broken tip on crown wheel, pinion, sun gear and planetary pinion.
2. Check the backlash.
3. Check the crown wheel run out.

**Assembly of differential:**

1. Install the pinion gear.
  - Fit the pinion gear with bearing, crush washer, and nut.
  - Tighten the nut as per torque specification.
2. Assemble internal gears.
  - Place side gears, spider gears, and clutch packs into the carrier.
  - Ensure correct positioning and fitment of shims.
3. Attach the ring gear.
  - Mount the ring gear back onto the differential case.
  - Tighten bolts evenly to the specified torque.
4. Adjust preload and backlash.
  - Use a dial indicator to check backlash.
  - Adjust preload and backlash to match manufacturer specs.
5. Install the carrier.
  - Refit the carrier into the differential housing.
  - Tighten the carrier cap bolts securely.
6. Reinstall differential unit.
  - Place the complete differential back into the axle housing.
  - Reconnect axle shafts and tighten housing bolts.

**XI. Observations:**

Student shall identify, observe the differential components and draw sketches.

1. Number of teeth on Crown Wheel (Ring gear) = .....
2. Number of teeth on Bevel pinion = .....
3. In the differential the crown wheel is meshed to ..... (drive pinion/axle shaft)

Sr. No.	Components	Diagram
1.	Crown Wheel and Pinion	
2.	Sun and Planetary Gear Set	
3.	Cage	
4.	Bearing	

**XII. Results**

$$\text{Final drive ratio} = \frac{\text{Number of teeth on crown wheel}}{\text{Number of teeth on bevel pinion}}$$

= .....

**XIII. Interpretation of Results**

.....

.....

.....

.....

.....

.....

.....



-----

-----

-----

-----

-----

**XVI. References / Suggestions for Further Reading**

1. <https://www.youtube.com/watch?v=F40ZBDAG8-o>
2. <https://www.youtube.com/watch?v=afTqwxfAyg>
3. <https://www.youtube.com/watch?v=gIGvhvOhLHU>
4. <https://www.youtube.com/watch?v=nC6fsNXdcMQ>
5. <https://www.youtube.com/watch?v=OxmfUeX1gOs>
6. [https://www.youtube.com/watch?v=4j\\_n1sddPh4](https://www.youtube.com/watch?v=4j_n1sddPh4)
7. <https://www.youtube.com/watch?v=d9cxw9d-css>
8. <https://www.youtube.com/watch?v=XLtC5re9Fak>
9. <https://www.youtube.com/watch?v=UIIk305-zlQ>

**XVII. Rubrics for Assessment Scheme**

Performance Indicators		Weightage
<b>Process Related (15 Marks)</b>		<b>(60%)</b>
1	Preparation of Practical set up, Safety measures and standard practices	20%
2	Handling of service tools carefully while performing the practical.	20%
3	Identify the probable Causes of the Troubles ,Inspection, Record Keeping, Reassembly	20%
<b>Product Related (10 Marks)</b>		<b>(40%)</b>
4	Interpretation of result	20%
5	Conclusions	10%
6	Practical related questions	10%
<b>Total</b>		<b>100 %</b>

Marks Obtained			Dated signature of Teacher
Process Related (15)	Product Related (10)	Total (25)	

**Practical No. 06: \*Repair drum or disc brake.****I. Practical Significance**

Repairing disc and drum brakes is essential to ensure the vehicle's braking system functions effectively and safely. Over time, brake components wear out due to friction and heat, which can reduce braking efficiency and increase stopping distances. Timely repairs help restore optimal performance, prevent further damage to related parts like rotors or drums, and reduce the risk of brake failure. This not only enhances road safety but also extends the lifespan of the braking system and reduces long-term maintenance costs.

**II. Industry / Employer Expected Outcome(s)**

1. Identify the type of braking system used in the given machine.
2. Individuals to have the skills to inspect, service, and repair both disc and drum brakes effectively.

**III. Course Level Learning Outcome(s)**

CO3 - Diagnose faults in given automobile control systems. (Braking System)

**IV. Laboratory Learning Outcome(s)**

1. Repair Drum and Disc Brake.
2. Compare Drum and Disc Brakes.
3. Carry out brake bleeding procedure.

**V. Relevant Affective Domain related Outcome(s)**

1. Follow safety practices.
2. Demonstrate working as a leader/a team member.
3. Maintain tools and equipments.
4. Follow ethical practices.

**VI. Minimum Theoretical Background**

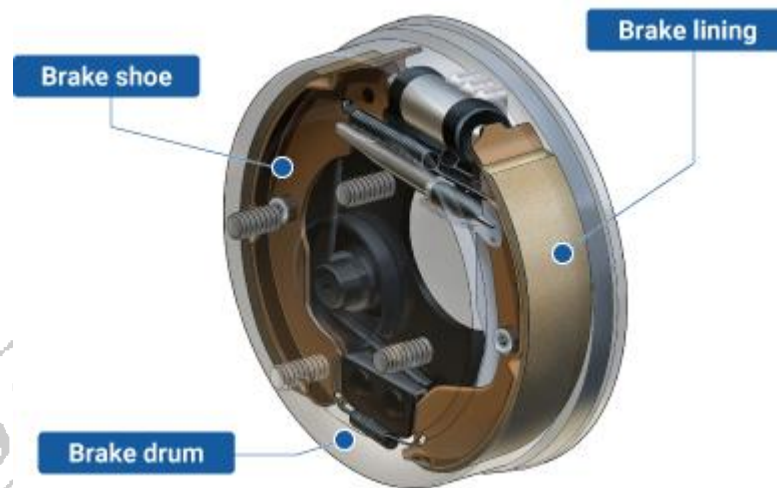
The braking system is designed to slow down or stop a moving vehicle and keep it stationary when needed. The two main types of braking systems used in vehicles are.

- 1. Drum brakes**
- 2. Disc brakes**

**1. Drum brake**

Drum brakes are a type of braking system commonly used on the rear wheels of many vehicles. They consist of a hollow, cylindrical drum that rotates with the wheel, and inside this drum are brake shoes lined with friction material. When the driver presses the brake pedal, hydraulic pressure from the brake fluid pushes pistons inside the wheel cylinder, forcing the brake shoes outward against the inner surface of the drum. This contact creates friction, which slows down and eventually stops the wheel's rotation. Drum brakes also have return springs that pull the brake shoes back to their resting position when the brake pedal is released. An adjuster mechanism helps maintain the proper distance between the shoes and drum as the friction material wears over time.

While drum brakes are generally less expensive and have a built-in parking brake mechanism, they tend to dissipate heat less efficiently than disc brakes and can be more prone to brake fade during heavy use.



**Fig.6.1 Drum Brake**

## 2. Disc brake

Disc brakes are a modern braking system that offers superior performance compared to traditional drum brakes. The system consists of a rotating disc (rotor) attached to the wheel and a caliper that houses brake pads. When the brake pedal is pressed, hydraulic pressure forces the caliper pistons to clamp the pads onto the disc, creating friction that slows the vehicle. This design allows for better heat dissipation, reducing brake fade during heavy use. Disc brakes are commonly used in front wheels of most vehicles and in high-performance cars due to their consistent stopping power, easier maintenance, and quick response. However, they are more expensive than drum brakes and may produce noise under harsh braking. Their self-cleaning ability (shedding water and debris) and durability make them ideal for modern automotive applications, ensuring safety and reliability in various driving conditions.



**Fig.6.2 Disc Brake**

## VII. Experimental Setup

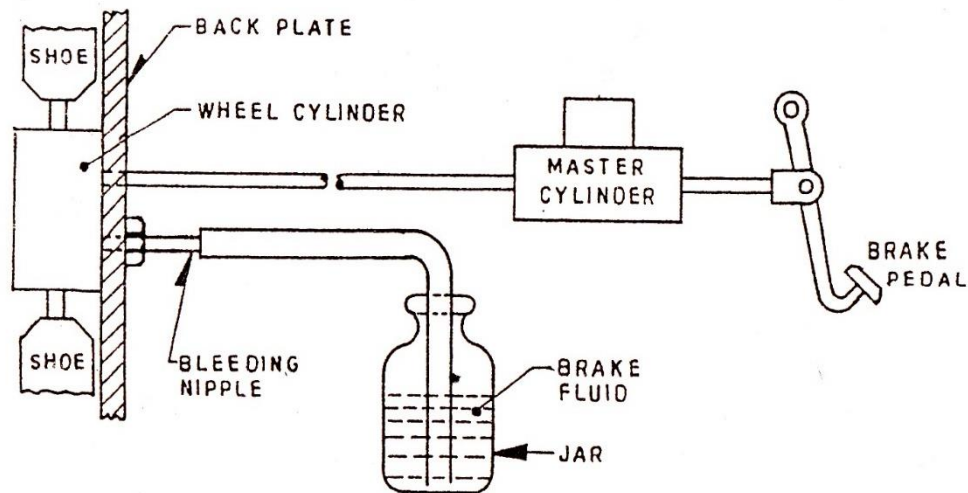


Fig.6.3 Setup of break bleeding.

## VIII. Required Resources/apparatus/equipment with specifications

Sr. No	Instrument /Components	Specification
1.	Working model of the drum/disc brake	Anyone from the Mechanical or Hydraulic drum brake and model of disc brake.
2.	General & Special tools	Hand Tools

## IX. Precautions to be followed

1. Refer to the relevant service handbook to perform repair, inspection, and reassembly.
2. Use the right tools and follow the right procedure for each exercise.

## X. Procedure.

### • Dismantling Drum brakes:

1. Park the vehicle safely, apply the handbrake, and chock the wheels.
2. Lift the vehicle using a jack and secure it with jack stands.
3. Remove the wheel from the drum brake side.
4. Tap and pull out the brake drum gently.
5. Note the position of springs and hardware before removing.
6. Remove return springs, brake shoes, and adjuster mechanism using brake pliers.
7. Disconnect the wheel cylinder if needed for inspection or replacement.

### • Inspection procedure:

1. Inspect brake shoes for wear – replace if the lining is below minimum thickness.
2. Check the drum for scoring, cracks, or oval shape resurface or replace if damaged.
3. Inspect the wheel cylinder for leakage or corrosion – rebuild or replace if necessary.
4. Check return springs for tension – replace if weak or corroded.
5. Inspect the adjuster mechanism – ensure smooth operation and proper threading.

6. Look for grease or brake fluid leaks inside the drum area.

- **Assembly procedure:**

1. Clean all components thoroughly using brake cleaner.
2. Install new or good-condition brake shoes onto the backing plate.
3. Reinstall the return springs, adjuster, and hold-down springs in the correct orientation.
4. Ensure the adjuster is set properly to maintain correct shoe-to-drum clearance.
5. Check the wheel cylinder pistons move freely.
6. Reinstall the brake drum and spin the wheel to check for free rotation.
7. Press the brake pedal multiple times to seat the brake shoes.
8. Reinstall the wheel, tighten the bolts, and lower the vehicle.
9. Perform a road test to confirm proper braking performance.

- **Dismantling Disc brakes:**

1. Secure the vehicle, engage parking brake, and loosen wheel nuts.
2. Lift the vehicle with a jack and place it on jack stands.
3. Remove the wheel to expose the disc brake assembly.
4. Unscrew the caliper bolts and carefully lift off the caliper.
5. Do not hang the caliper by the brake hose — support it with a hook or rope.
6. Slide out the brake pads from the caliper bracket.
7. Remove the caliper bracket (if rotor removal is needed).
8. Pull off the brake disc (rotor) — may require tapping if stuck due to rust.

- **Inspection procedure:**

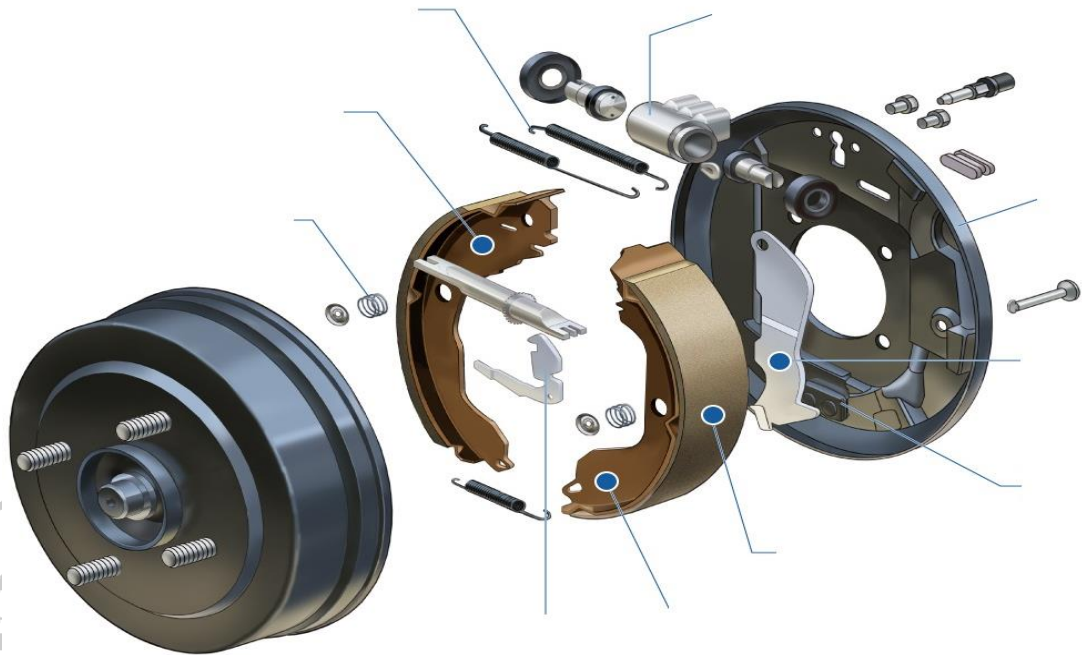
1. Check brake pads for thickness and uneven wear — replace if below limit.
2. Inspect the rotor for scoring, cracking, or warping — resurface or replace as needed.
3. Check caliper pistons for sticking or leakage.
4. Examine slide pins for smooth movement and proper lubrication.
5. Inspect the brake hose for cracks or bulges.
6. Check the pad retaining clips and anti-rattle shims for wear or damage.

- **Assembly procedure:**

1. Clean all components with brake cleaner.
2. Lubricate slide pins and contact points with high-temp brake grease.
3. Install the rotor and secure it in place (if applicable).
4. Reinstall the caliper bracket and torque the bolts.
5. Insert new or serviceable brake pads into the bracket.
6. Retract the caliper piston using a brake tool or C-clamp to fit over the new pads.
7. Reinstall the caliper and tighten bolts to specification.
8. Reinstall the wheel, lower the vehicle, and torque the wheel nuts.
9. Pump the brake pedal to restore brake pressure before driving.

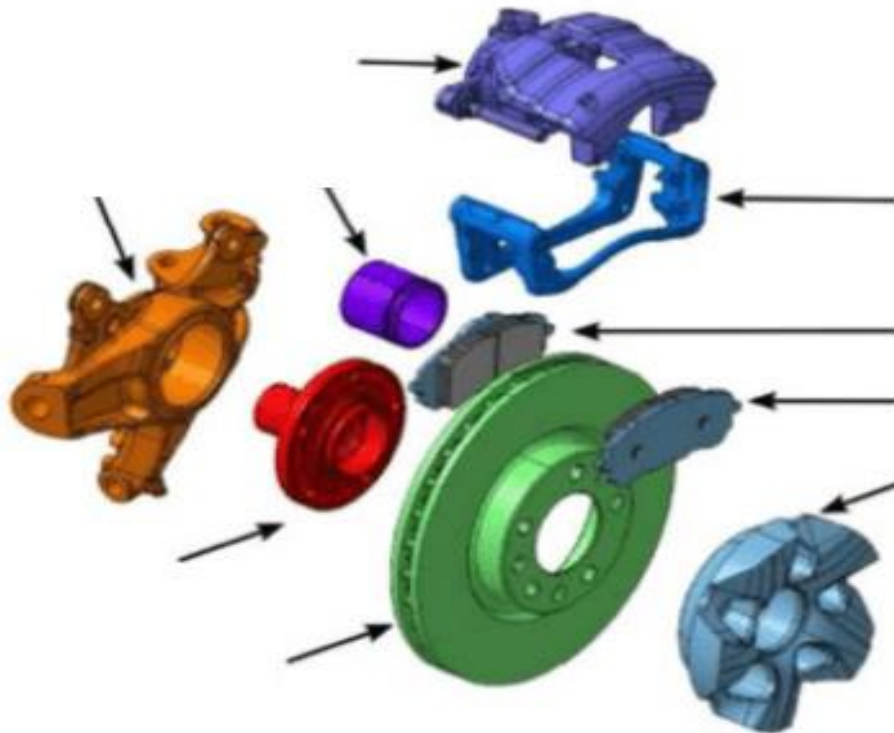
**XI. Observation**

1. Identify the Parts of Drum Brake in the assemblies and label the parts in the figures.



**Fig.6.4 Drum Brake (Identify the components of the drum brake)**

2. Identify the Parts of the Disc Brake in the assemblies and label the parts in the figures.



**Fig.6.5 Disc Brake (Identify the components of the disc brake)**



**XII. Results**

.....

.....

.....

.....

.....

**XIII. Interpretation of Results**

.....

.....

.....

.....

.....

**XIV. Conclusions and Recommendations**

.....

.....

.....

.....

.....

**XV. Practical related questions**

*Note: Below are a few sample questions for reference. Teachers must design more such questions to ensure the achievement of the identified CO.*

1. List and describe the main functions and essential requirements of a braking system.
2. Compare disc brakes and drum brakes based on their design, performance and maintenance.
3. Identify the key components of a disc brake system and explain the function of each part.
4. State the advantages and disadvantages of disc and drum brakes.

**[Space for Answer]**

.....

.....

.....

.....

.....

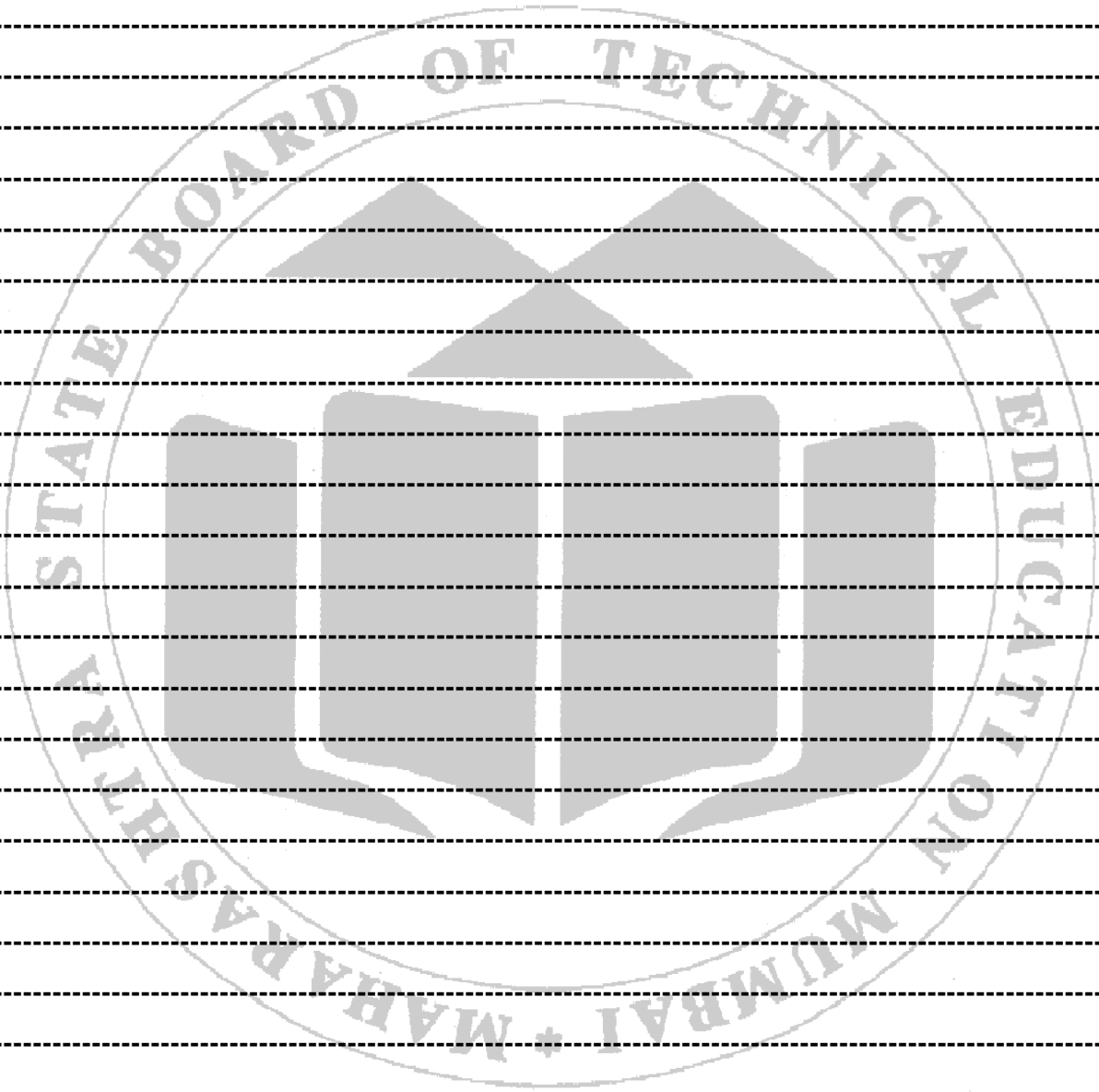
.....

.....

.....

.....

.....



**XVI. References/Suggestions for further reading: include websites/links**

1. <https://www.youtube.com/watch?v=HDzYsQn4rIE>
2. <https://www.youtube.com/watch?v=TlbCFzJ8eQ4>

**XVII. Rubrics for Assessment Scheme**

<b>Performance Indicators</b>		<b>Weightage</b>
<b>Process Related (15 Marks)</b>		<b>(60%)</b>
1	Preparation of Practical set up, Safety measures and standard practices	20%
2	Handling of service tools carefully while performing the practicals.	20%
3	Identify the probable Causes of the Troubles, Inspection, Record Keeping, Reassembly	20%
<b>Product Related (10 Marks)</b>		<b>(40%)</b>
4	Interpretation of result	20%
5	Conclusions	10%
6	Practical related questions	10%
<b>Total</b>		<b>100 %</b>

<b>Marks Obtained</b>			<b>Dated signature of Teacher</b>
<b>Process Related (15)</b>	<b>Product Related (10)</b>	<b>Total (25)</b>	

**Practical No. 07: Steering system.****I. Practical Significance**

The steering system controls a vehicle's direction, ensuring safety, comfort, and efficient handling. It allows the driver to maneuver accurately, reduces physical effort through power assistance, and supports advanced features like lane-keeping and automatic parking. A well-functioning steering system improves fuel efficiency and extends tire life by maintaining proper alignment. Its integration with modern technologies makes it essential for both manual and autonomous driving systems.

**II. Industry / Employer Expected Outcome(s)**

1. Students can identify and explain the function of the main components.
2. Collaborate effectively and explain technical concepts during the practical session.

**III. Course Level Learning Outcome(s)**

CO3 - Diagnose faults in given automobile control systems. (Steering System)

**IV. Laboratory Learning Outcome(s)**

1. Identify components of steering Systems.
2. Draw steering linkages.
3. Identify possible causes of failure in the steering system.
4. Suggest remedial action.

**V. Relevant Affective Domain related Outcome(s)**

1. Follow safety practices.
2. Demonstrate working as a leader/a team member.
3. Maintain tools and equipment.
4. Follow ethical Practices.

**VI. Minimum Theoretical Background**

The steering system is a key component of a vehicle that allows the driver to control its direction. It connects the steering wheel to the wheels, enabling smooth and safe turning. Modern systems often include power assistance for easier handling.

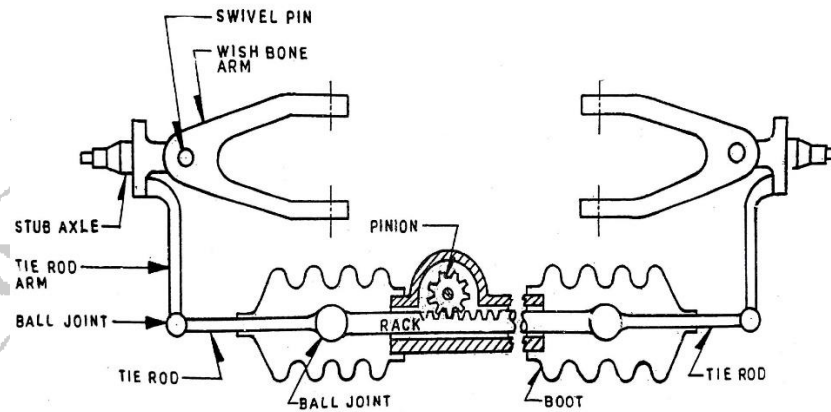
The main components of a steering system include the steering wheel, which the driver uses to input direction, and the steering column, which connects the wheel to the mechanism. The rack and pinion or steering gearbox converts the rotary motion into linear motion. Tie rods transmit this motion to the steering knuckles, turning the wheels.

Types of steering gear boxes.

1. Rack and Pinion Gearbox
2. Recirculating Ball Gearbox
3. Worm and Roller Gearbox
4. Worm and Sector Gearbox
5. Cam and Lever Gearbox

## 1. Rack and Pinion Gearbox

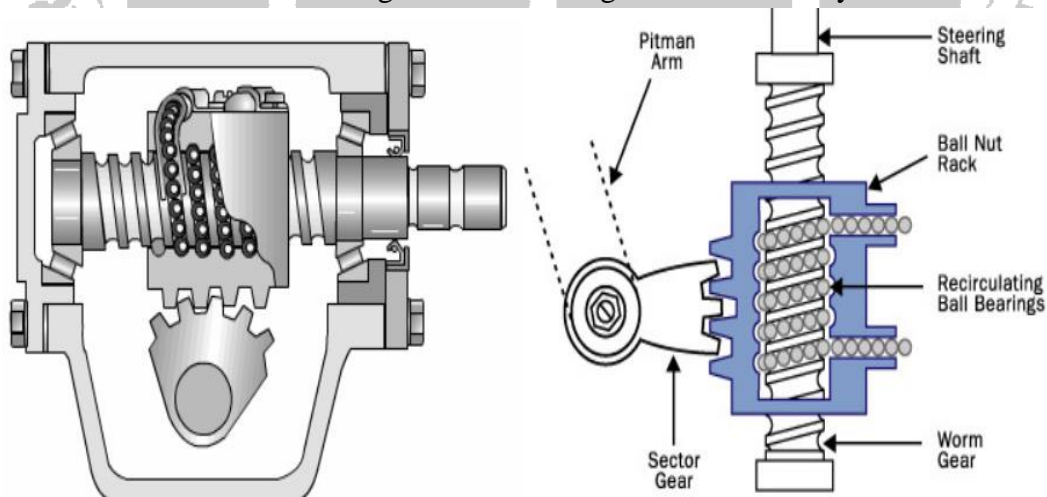
The rack and pinion steering system is a simple and efficient mechanism used to convert the rotational motion of the steering wheel into linear motion needed to turn the wheels. In this system, the pinion gear is connected to the steering shaft and meshes with a toothed rack. When the steering wheel is turned, the pinion rotates and moves the rack left or right. This motion is transferred to the wheels through tie rods and ball joints, allowing for precise and smooth steering. The system is compact, lightweight, and widely used in modern vehicles for its accuracy and responsiveness.



**Fig.7.1 Rack and Pinion Gearbox.**

## 2. Recirculating Ball Gearbox

The recirculating ball-type steering gear is commonly used in heavy-duty vehicles due to its strength and durability. In this system, the steering wheel turns a worm gear, which is connected to a nut filled with ball bearings. These ball bearings circulate in a loop between the worm and nut, reducing friction and allowing smooth movement. As the worm rotates, the nut moves along its length, turning a wheel sector connected to a cross shaft. This motion is then transferred to the drop arm and link rod, ultimately turning the vehicle's wheels. This system provides a mechanical advantage and handles high loads effectively.



**Fig.7.2 Recirculating ball-type steering gear box**

## VII. Experimental Setup

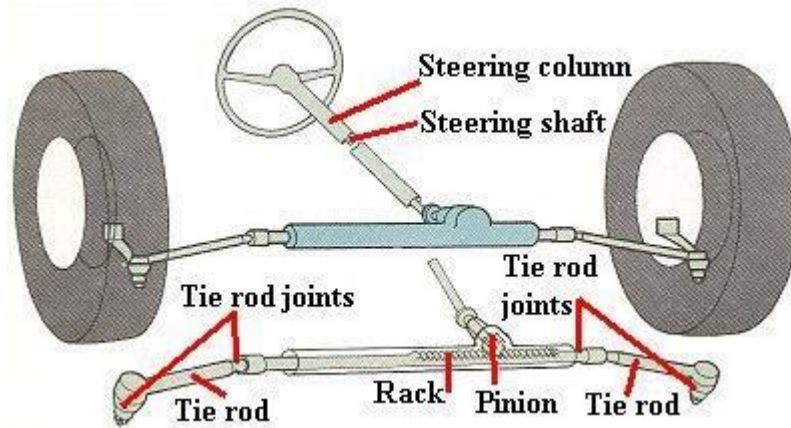


Fig.7.3 Setup of Rack and Pinion gearbox.

## VIII. Required Resources/apparatus/equipment with specifications

Sr. No	Instrument /Components	Specification	Quantity
1	Car with rack and pinion steering gear	Maruti 800 car Or Car having Rack and pinion Steering gear/ recirculating ball Type/Worm and Wheel type gear	1
2	Hand tools and special tools	Hand tools: Pipe wrench. Tie rod puller and other tools, Ball Joint Extractor and Separator fork set Special Tools: Torque Wrench	1
3	Puller set	Puller set for steering wheels, sprockets, Pulley sand shafts. Range $\text{Ø } 32$ to $\text{Ø } 90$ mm with spindle	1
4	Steering wheel puller	Steering wheels that are stuck on the steering column may be pulled off clearly and without damage to the steering column and steering wheel With the puller.	1
5	Steering wheel puller	Steering wheels which are stuck on the steering column may be pulled off clearly and without damage to the steering column and steering wheel with the puller.	1
6	Mounting tool set	The toolset allows a quick and easy removal and replacement of the inner steering ball joint without the need to dismantle the steering rack from the bulkhead. Drive head Range $\text{Ø } 35$ to $\text{Ø } 39$ mm	1

Sr. No	Instrument /Components	Specification	Quantity
7	Alignment tool set	As per the available vehicle service manual specifications	1

### IX. Precautions to be followed

1. Refer to the relevant service handbook to perform repair, inspection, and reassembly.
2. Use the right tools and follow the right procedure for each exercise.
3. Do not force any part during disassembly or alignment to prevent damage.
4. Use correct tools for measuring and adjusting steering angles.
5. Keep in mind the right-hand threads and left-hand threads at the tie rods.

### X. Procedure.

#### Dismantling

For precise steps and directions, see the repair manual provided by the manufacturer of the original equipment. The regular service manual approach can be used to rebuild the steering gearbox.

1. Unplug the battery's negative cable. Take off the covers for the upper and lower steering columns.
2. Unplug the gear housing's universal joint. Before taking out the set bolts, place the matchmarks.
3. Lift the car and provide safe support.
4. Take off the front two wheels.
5. Take off the nuts and cotter pins from both tie rod joints.
6. Take off both tie rod joints from the steering knuckles using a tie rod separator.
7. If required, lower the engine after supporting the engine assembly and removing the engine mounting.
8. The nuts and bolts that hold the steering rack to the body should be removed.
9. To remove the rack and pinion assembly from the car, remove any additional parts that are required to obtain working access (if at all possible, slide the assembly out the wheel well opening). Take out the rack assembly.

#### Inspection:

1. Check for excessive wear on the rack and pinion.
2. Take hold of the tire and check the inner tie rods for looseness. If you notice any looseness, make sure the inner tie rod is slack by looking under the belly. If a tie rod inside is loose, swap out the gear.
3. Check for damage to the bellows.

#### Assembling:

1. Put the rack assembly in place. Tighten the nuts and retaining bolts EVENLY to 58 Nm to secure it.
2. Attach each steering knuckle to the tie rods. The nuts should be tightened to 48 Nm and Put in fresh cotter pins. Securely wrap the cotter pin's prongs around the nuts' flats.
3. Fit the front wheels.

4. Bring the vehicle down to the floor.
5. Attach the universal joint to the steering gear housing after aligning the matchmarks. The upper and lower set bolts should be tightened to 35 Nm.
6. Put the cover on the steering column. Reattach the battery's negative cable. Verify the alignment of the front wheels.

## XI. Observation

### a. Basic observation of Rack and Pinion Gearbox and Recirculating Ball Gearbox

Sr. No.	Observation Point	Rack and Pinion Gearbox	Recirculating Ball Gearbox
1	Type of Motion		
2	Steering Effort		
3	Components Observed		
4	Response to Steering Input		
5	Free Play		
6	Smoothness of Operation		
7	Application		

**b. Parts of the Rack and Pinion Gearbox and Their Functions**

Sr. No.	Part Name	Function
1	Steering Wheel	
2	Steering Shaft	
3	Pinion Gear	
4	Rack (Toothed Bar)	
5	Tie Rods	
6	Ball Joints	
7	Rubber Boot (Bellows)	

**XII. Results**

-----

-----

-----

-----

**XIII. Interpretation of Results**

-----

-----

-----

-----

-----

**XIV. Conclusions and Recommendations**

-----

-----

-----

-----

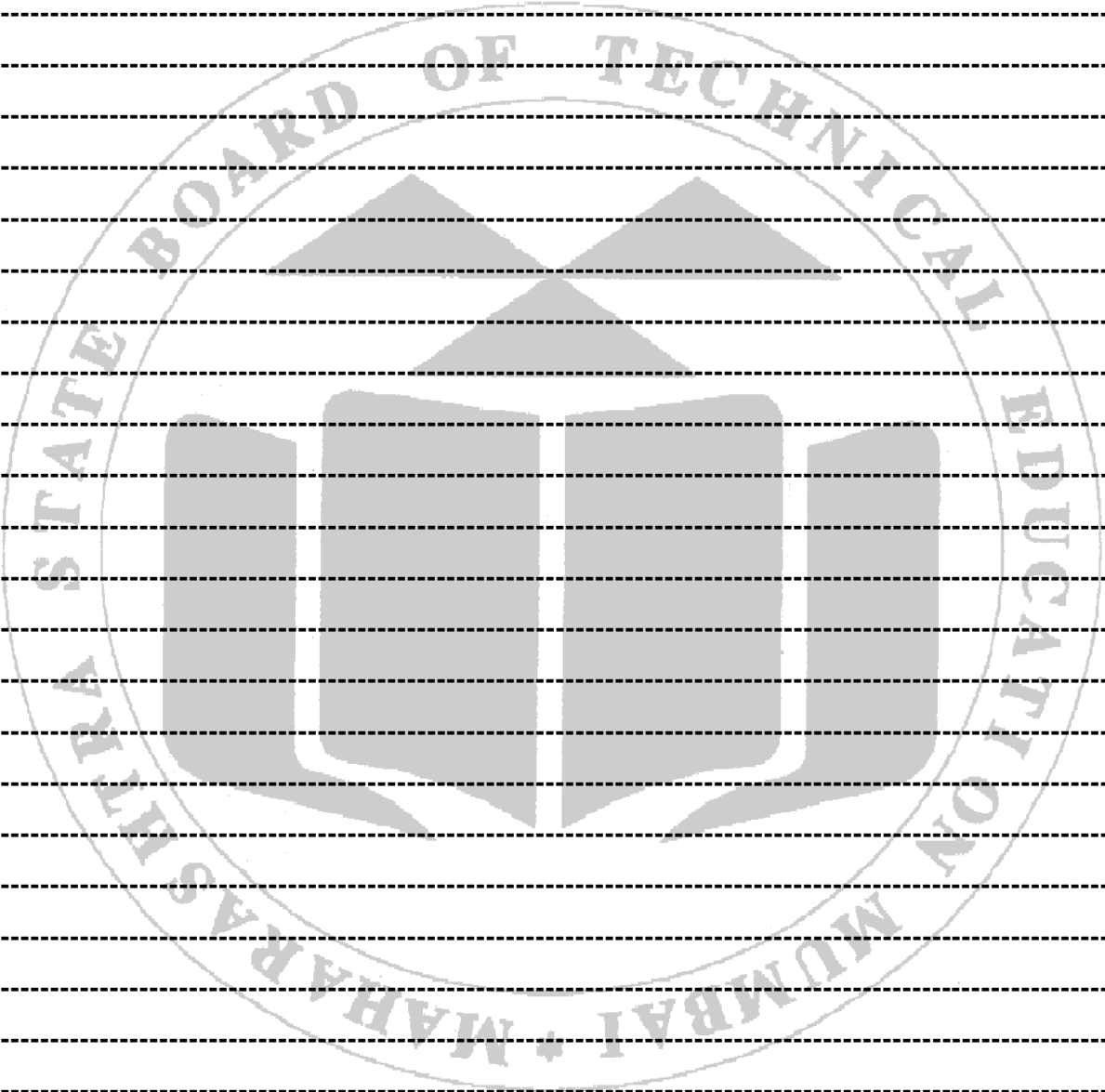
-----

**XV. Practical related questions**

*Note: Below are a few sample questions for reference. Teachers must design more such questions to ensure the achievement of the identified CO.*

1. Draw a clear diagram of the recirculating ball-type steering gearbox and label its main parts.
2. Sketch and label the rack and pinion type steering gearbox to show how it works.

**[Space for Answer]**



A large area of the page is filled with horizontal dashed lines, providing space for the student to draw and label the steering gearboxes as requested in the questions above.

**XVI. References/Suggestions for further reading: include websites/links**

1. <https://www.youtube.com/watch?v=VgIkpPON5fk>
2. <https://www.youtube.com/watch?v=RDD6Ecg-fBU>

**XVII. Rubrics for Assessment Scheme**

<b>Performance Indicators</b>		<b>Weightage</b>
<b>Process Related (15 Marks)</b>		<b>(60%)</b>
1	Preparation of Practical set up, Safety measures and standard practices	20%
2	Handling of service tools carefully while performing the practical.	20%
3	Identify the probable Causes of the Troubles, Inspection, Record Keeping, Reassembly	20%
<b>Product Related (10 Marks)</b>		<b>(40%)</b>
4	Interpretation of result	20%
5	Conclusions	10%
6	Practical related questions	10%
<b>Total</b>		<b>100 %</b>

<b>Marks Obtained</b>			<b>Dated signature of Teacher</b>
<b>Process Related (15)</b>	<b>Product Related (10)</b>	<b>Total (25)</b>	

**Practical No. 08: \* Suspension system.****I. Practical Significance**

The suspension system significantly enhances vehicle stability, comfort, and handling by absorbing road shocks and maintaining tire contact with the surface. It improves safety by reducing body roll during turns and minimizing braking distance. Additionally, it ensures better load distribution and prolongs the lifespan of vehicle components. Overall, it delivers a smoother and safer driving experience, especially on uneven terrain.

**II. Industry / Employer Expected Outcome(s)**

1. Demonstrate knowledge of suspension components and their functions.
2. Improve problem-solving and teamwork skills.

**III. Level Learning Outcome(s)**

CO4 - Locate faults in the suspension system of a given automobile.

**IV. Laboratory Learning Outcome(s)**

1. Identify components of Suspension systems.
2. Compare rigid axle and independent suspension systems.
3. Identify possible faults.
4. Suggest remedial action.

**V. Relevant Affective Domain related Outcome(s)**

1. Follow safety practices.
2. Demonstrate working as a leader/a team member.
3. Maintain tools and equipment.
4. Follow ethical practices.

**VI. Minimum Theoretical Background**

A suspension system is a vital part of a vehicle that connects the wheels to the chassis and helps absorb shocks from uneven road surfaces. It ensures a smooth and safe ride by maintaining tire contact with the road and improving handling, braking, and comfort. The main components include springs, dampers (also known as shock absorbers) and linkages.

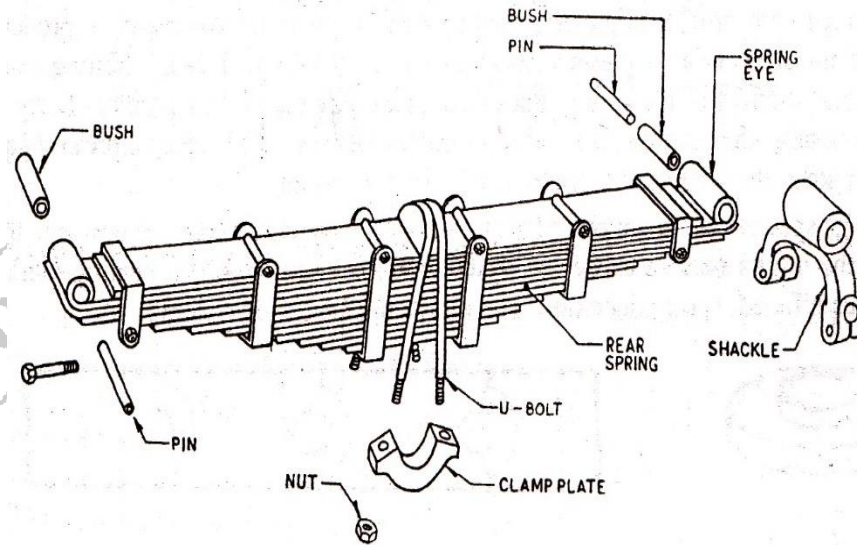
**Types of Suspension Systems:**

- **Dependent Suspension** – Both wheels are connected, and movement in one affects the other (e.g. solid axle/leaf spring).
- **Independent Suspension** – Each wheel moves independently, improving comfort and handling (e.g. MacPherson strut, double wishbone).

- **Leaf spring.**

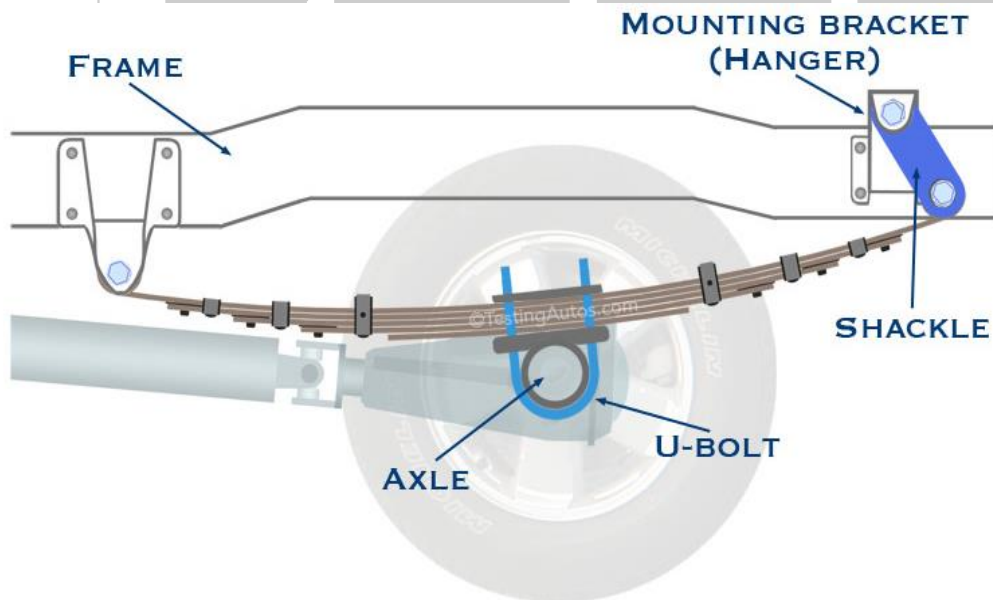
The leaf spring suspension system which is commonly used in heavy vehicles like trucks and buses. This system consists of several key components. The frame side member is part of the vehicle's chassis to which the suspension is mounted. The master leaf is the main leaf in the spring assembly, usually with eyes at both ends for attachment. Rubber bushes are used at the

mounting points to reduce vibrations and noise. The U-bolt holds the leaf spring firmly to the rear axle, allowing power transmission to the wheels. The clip or strap keeps the leaf springs aligned during movement. The spring eye is where the leaf spring is bolted to the frame, and the shackle allows for the spring's length change during compression or extension, improving flexibility. This type of suspension helps absorb road shocks, supports heavy loads, and ensures a smoother ride



**Fig.8.1 Leaf Spring**

**VII. Experimental Setup**



**Fig.8.2 Experimental setup of leaf spring.**

**VIII. Required Resources/apparatus/equipment with specifications**

Sr. No.	Resource Name	General Description	Required Quantity
1	Vehicle	A vehicle equipped with a leaf spring suspension system	1 unit
2	Support Stand	Suitable type based on vehicle category	2 units
3	Safety Equipment	Safety goggles, gloves, an apron, and other protective gear	Sufficient for the group size
4	Basic Tools	Complete set of general-purpose hand tools	2 sets
5	Maintenance Supplies	Includes silicone grease, cleaning cloths, and brushes	As needed

**IX. Precautions to be followed**

1. Refer to the relevant service handbook to perform repair, inspection, and reassembly.
2. Use the right tools and follow the right procedure for each exercise.
3. Do not force any part during disassembly or alignment to prevent damage.

**X. Procedure.**

- **Dismantling process (Removing the Leaf spring):**

1. Park the vehicle on a flat, safe surface.
2. Apply the handbrake and place wheel chocks.
3. Use a jack to lift the vehicle body.
4. Place jack stands under the chassis/frame for safety.
5. Remove the rear wheels using a wheel spanner.
6. Support the rear axle with a secondary jack or stand.
7. Loosen and remove the U-bolts holding the leaf spring to the axle.
8. Remove the front spring eye bolt.
9. Disconnect the rear shackle bolt.
10. Carefully slide out and remove the leaf spring from the vehicle.

- **Inspection process (Check Leaf spring condition):**

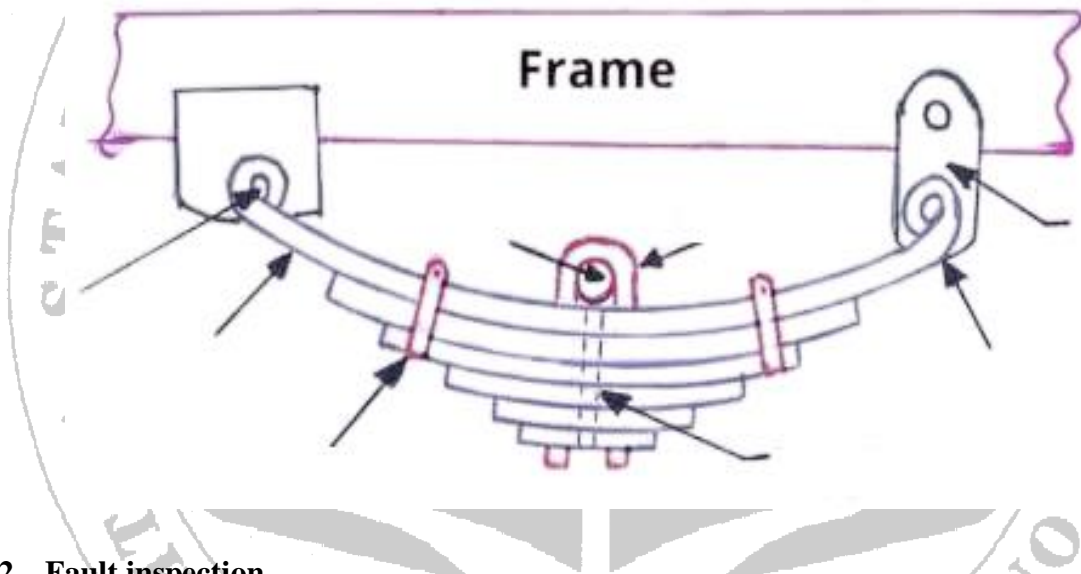
1. Check all leaf spring leaves for cracks, rust, or deformation.
2. Inspect the spring eye and shackle bushings for wear or damage.
3. Ensure U-bolts are not bent, worn, or stripped.
4. Check for corrosion or damage on the frame mounting points.
5. Examine clips/straps and center bolt for proper condition.
6. Replace damaged components or lubricate as needed before reassembly.

• **Assembly process (Installing the Leaf spring):**

1. Position the new or inspected leaf spring into place.
2. Align the spring eye with the front bracket and insert the bolt.
3. Connect the rear end to the shackle and insert the shackle bolt.
4. Align the spring center pin with the axle seat.
5. Place the U-bolts over the axle and tighten the nuts evenly.
6. Ensure all bolts are securely fastened (use a torque wrench if available).
7. Refit the rear wheels and tighten the nuts.
8. Remove the jack stands and lower the vehicle slowly.
9. Recheck all bolts and fasteners for tightness.
10. Perform a short test drive and listen for unusual noises or instability.

**XI. Observation**

**1. Identify the parts**



**2. Fault inspection**

Sr. No.	Observed Fault	Possible Cause	Remedy
1	The leaf spring is flat or sagging		
2	The vehicle tilts to one side		
3	Cracks on spring leaves		

Sr. No.	Observed Fault	Possible Cause	Remedy
4	Noisy suspension (clunking or squeaking)		
5	Excessive vibration or a rough ride		
6	Loose or misaligned U-bolts		

**XII. Results**

-----

-----

-----

-----

**XIII. Interpretation of Results**

-----

-----

-----

-----

-----

-----

**XIV. Conclusions and Recommendations**

-----

-----

-----

-----

-----

**XV. Practical related questions**

*Note: The following are a few sample questions for your reference. Teachers must design more such questions to ensure the achievement of the identified CO.*

1. Draw and label a clear diagram of a double wishbone suspension system.
2. Explain the meaning of 'nipping' in a multi-leaf spring assembly and describe its purpose.
3. Compare the MacPherson strut and double wishbone suspension systems in terms of design, performance, and applications.



**XVII. Rubrics for Assessment Scheme**

<b>Performance Indicators</b>		<b>Weightage</b>
<b>Process Related (15 Marks)</b>		<b>(60%)</b>
1	Preparation of Practical setup, Safety measures, and standard practices	20%
2	Handling of service tools carefully while performing the practical.	20%
3	Identify the probable Causes of the Troubles, Inspection, Record Keeping, and Reassembly	20%
<b>Product Related (10 Marks)</b>		<b>(40%)</b>
4	Interpretation of the result	20%
5	Conclusions	10%
6	Practical related questions	10%
<b>Total</b>		<b>100 %</b>

<b>Marks Obtained</b>			<b>Dated signature of Teacher</b>
<b>Process Related (15)</b>	<b>Product Related (10)</b>	<b>Total (25)</b>	

**Practical No. 09: \* Carry out battery test.****I. Practical Significance**

Carrying out a battery test is important to ensure the battery can start the engine and power electrical systems reliably. It helps detect weak or faulty batteries early, preventing sudden breakdowns. Regular testing also identifies charging system issues like alternator faults. This improves vehicle safety, performance and reduces unexpected maintenance costs.

**II. Industry / Employer Expected outcome(s)**

1. The candidate can identify whether starting problems are due to battery failure or issues in the charging system.
2. The candidate can use tools like a multimeter, battery tester, or hydrometer to assess battery voltage, state of charge, and health.

**III. Course Level Learning outcome(s)**

CO5 - Carryout appropriate test for given auto electrical and electronic components.

**IV. Laboratory Learning outcome(s)**

1. Perform battery test
2. Analyze the result of the Open Voltage and Specific Gravity test for the battery.

**V. Relevant Affective Domain related outcome(s)**

1. Follow safety practices.
2. Demonstrate working as a leader/a team member.
3. Maintain tools and equipment.
4. Follow ethical Practices.

**VI. Minimum Theoretical Background**

A battery in an automobile is a vital component that stores electrical energy and supplies it to start the engine and operate electrical systems such as lights, ignition, and infotainment. The most commonly used type is the lead-acid battery, known for its reliability and cost-effectiveness. It converts chemical energy into electrical energy through an electrochemical reaction. A fully charged automotive battery typically provides 12 volts. Regular testing and maintenance of the battery are important to ensure dependable vehicle operation and to prevent sudden breakdowns.

**Type of Battery Test**

1. Specific Gravity Test.
2. Open Circuit Voltage Test.

**Specific Gravity Test.**

The Specific Gravity Test is used to determine the state of charge of each cell in a lead-acid battery by measuring the density of the electrolyte (sulphuric acid solution). This is done using a hydrometer, which compares the weight of the electrolyte to that of water. A fully charged cell typically has a specific gravity of around 1.265 to 1.285, while a lower reading indicates a discharged or weak cell. By testing each cell individually, this method helps identify imbalances

or failing cells within the battery. It is an effective diagnostic tool but is applicable only to flooded (non-sealed) lead-acid batteries.

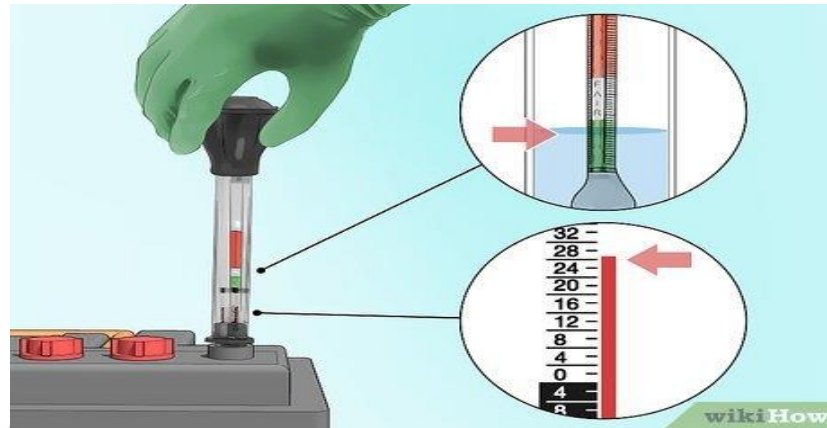
Specific Gravity	State of Charge
1.265 – 1.285	100% (Fully Charged)
1.225 – 1.265	75% – 90%
1.190 – 1.225	50% – 75%
1.155 – 1.190	25% – 50%
Below 1.155	Below 25% (Discharged)

### Open Circuit Voltage Test.

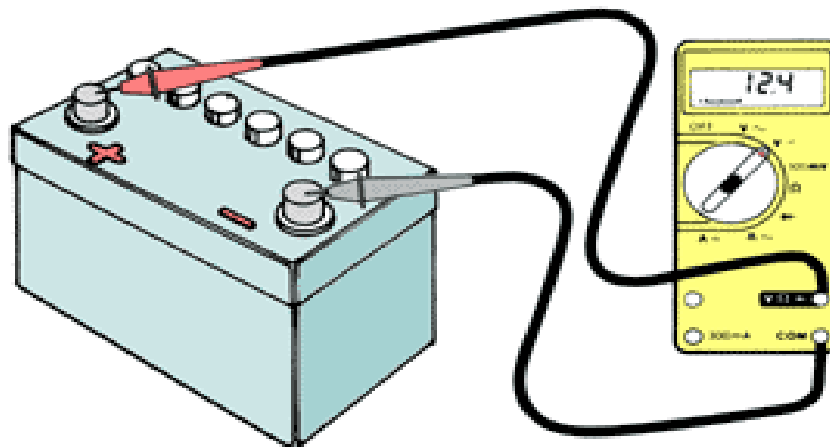
The Open Circuit Voltage (OCV) Test is a simple and effective method used to determine the state of charge of a battery without applying any load. This test involves measuring the battery's voltage across its terminals using a voltmeter while the battery is at rest, typically after being idle for a few hours. A fully charged 12V lead-acid battery will show an open circuit voltage of around 12.6 to 12.8 volts. If the voltage is lower, it indicates that the battery is partially or fully discharged. This test is useful for quickly assessing battery health and deciding if charging or replacement is needed.

Voltage (V)	State of Charge
12.7 – 12.8	100% (Fully Charged)
12.4 – 12.6	75–90%
12.2 – 12.3	50%
12.0 – 12.1	25%
Below 12.0	Discharged

**VII. Experimental Setup**



**Fig.9.1 Experimental setup of specific gravity test.**



**Fig.9.2: Experimental setup of Open Circuit Voltage Test.**

**VIII. Required Resources/apparatus/equipment with specifications**

Sr. No	Name of Resource	Suggested Broad Specification	Quantity
1	Hydrometer	Battery acid hydrometer, scale 1.100 to 1.400	1
2	Protective Gloves	Acid-resistant, chemical safety gloves	1 pair
3	Safety Goggles	Chemical splash resistant	1 pair
4	Clean Cloth	Absorbent for cleaning spills	1
5	Flat-head Screwdriver	For removing battery cell caps	1

Sr. No	Name of Resource	Suggested Broad Specification	Quantity
6	Voltmeter / Multimeter	Digital or analog, DC voltage measurement, 0-20V range	1
7	Battery	Lead-acid automotive battery	1

### IX. Precautions to be followed

1. Wear safety gloves and goggles to protect against acid.
2. Ensure the battery is fully charged before testing.
3. Use a clean and accurate hydrometer.
4. Avoid spilling electrolyte – it's corrosive.
5. Do not test near open flames or sparks.
6. Wipe up any spills immediately and wash your hands after handling.
7. Ensure the battery has been at rest (not charged or discharged) for at least 1–2 hours before testing.
8. Use a properly calibrated voltmeter and connect it correctly to avoid short circuits.

### X. Procedure.

#### Specific gravity test – step-wise procedure

1. Wear safety gloves and goggles and work in a well-ventilated area.
2. Remove the battery cell caps carefully to expose the electrolyte.
3. Prepare the hydrometer by ensuring it is clean and dry.
4. Squeeze the bulb of the hydrometer and draw electrolyte from the first cell.
5. Hold the hydrometer at eye level and read the specific gravity indicated by the float.
6. Record the specific gravity reading for that cell.
7. Repeat steps 4 to 6 for each remaining battery cell.
8. Compare the readings with the standard values (around 1.265–1.285 for fully charged).
9. Replace all cell caps securely after testing.
10. Clean any spilled electrolyte from the battery surface safely.

#### Open circuit voltage (OCV) test – procedure

1. Let the battery rest unused for 1–2 hours (preferably 8–12 hours) after charging or use.
2. Ensure all electrical devices and ignition are switched off.
3. Set the voltmeter to the DC voltage mode (20V range).
4. Connect the positive (red) voltmeter lead to the battery's positive terminal.
5. Connect the negative (black) voltmeter lead to the battery's negative terminal.
6. Read and record the voltage displayed on the voltmeter.
7. Compare the reading with standard voltage values to assess the battery's charge.
8. Disconnect the voltmeter leads safely after the measurement.

**XI. Observation****1. Specific gravity test**

Cell No.	Specific Gravity Reading	Standard Value	State of Charge (%)	Cell Condition (OK/Weak)
1		1.265 – 1.285		
2		1.265 – 1.285		
3		1.265 – 1.285		
4		1.265 – 1.285		
5		1.265 – 1.285		
6		1.265 – 1.285		

**2. Open circuit voltage test**

Battery ID / No.	Measured Voltage (V)	Standard Voltage (V)	State of Charge (%)	Battery Condition (OK/Low)
1		12.6 – 12.8		
2		12.6 – 12.8		
3		12.6 – 12.8		

**XII. Results**

-----

-----

-----

-----



**XVI. References/Suggestions for further reading: include websites/links**

1. <https://www.youtube.com/watch?v=gc7v923zyAQ>
2. <https://www.youtube.com/watch?v=M5H7UY55rrw>

**XVII. Rubrics for Assessment Scheme**

Performance Indicators		Weightage
<b>Process Related (15 Marks)</b>		<b>(60%)</b>
1	Preparation of Practical setup, Safety measures, and standard practices	20%
2	Handling of service tools carefully while performing the practical.	20%
3	Identify the probable Causes of the Troubles, Inspection, Record Keeping, and Reassembly	20%
<b>Product Related (10 Marks)</b>		<b>(40%)</b>
4	Interpretation of the result	20%
5	Conclusions	10%
6	Practical related questions	10%
<b>Total</b>		<b>100 %</b>

Marks Obtained			Dated signature of Teacher
Process Related (15)	Product Related (10)	Total (25)	

**Practical No. 10: Wheel balancing and wheel alignment.****I. Practical Significance**

Wheel balancing helps eliminate tyre vibrations and ensures smooth vehicle operation, improving tyre life and ride comfort. Wheel alignment ensures proper wheel angles for straight-line driving, preventing uneven tyre wear and enhancing safety. This practical teaches how to maintain vehicle stability and efficiency through proper balancing and alignment techniques.

**II. Industry / Employer Expected Outcome(s)**

1. Capability to identify common wheel and tyre issues affecting vehicle handling.
2. Skill to perform basic wheel alignment checks and adjustments for better tyre life and safety.

**III. Course Level Learning Outcome(s)**

CO4 - Locate faults in the steering geometry of a given automobile and the wheel balancing and alignment process.

**IV. Laboratory Learning Outcome(s)**

1. Identify the necessity of wheel balancing and wheel alignment.
2. List a stepwise procedure for wheel balancing and wheel alignment.

**V. Relevant Affective Domain related Outcome(s)**

1. Follow safety practices.
2. Demonstrate working as a leader/a team member.
3. Maintain tools and equipment.
4. Follow ethical Practices.

**VI. Minimum Theoretical Background****• Wheel balancing**

Wheel balancing is the process of equalizing the weight distribution of the tyre and wheel assembly so that it rotates evenly at high speeds without causing vibrations. When a wheel is out of balance, it creates uneven centrifugal forces, leading to vibrations, uneven tyre wear, poor handling, and increased stress on suspension components. This not only affects driving comfort but can also lead to premature failure of steering and suspension parts. Regular wheel balancing helps maintain vehicle stability, improve fuel efficiency, and extend the overall life of tyres and related components.

**Types of wheel imbalance:****1. Static imbalance:**

- Occurs when the weight is unevenly distributed around the wheel's diameter.
- Causes up-and-down vibrations (wheel hops).

**2. Dynamic imbalance:**

- Happens when weight is uneven across the wheel's width.
- Causes side-to-side vibrations or wobbling.

### Wheel Alignment

Wheel alignment refers to the proper adjustment of a vehicle's suspension components that position the wheels. It ensures that all wheels are set to the correct angles as per the manufacturer's specifications, allowing the vehicle to drive straight, handle properly, and reduce tyre wear.

Incorrect alignment can cause the vehicle to pull to one side, lead to uneven tyre wear, reduce fuel efficiency, and negatively affect vehicle safety and stability.

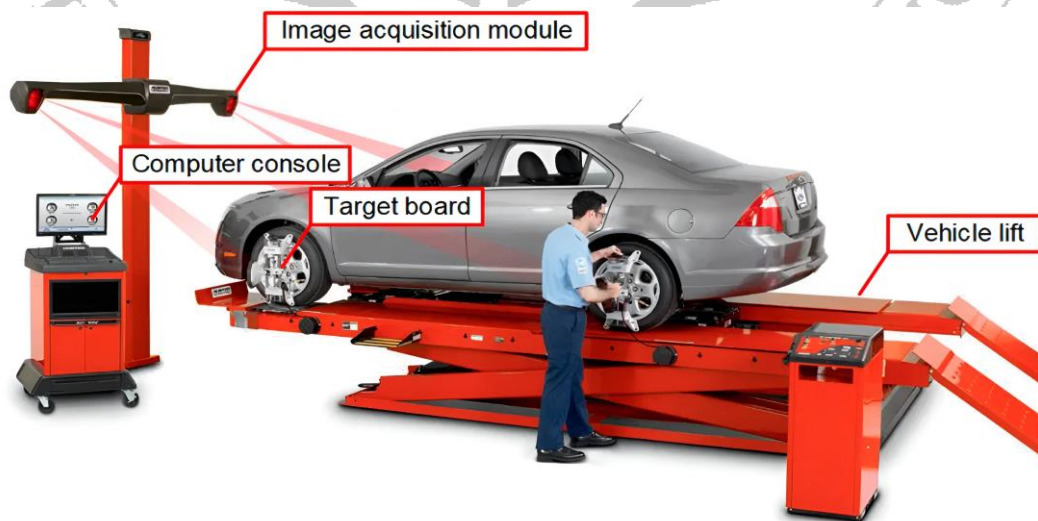
The three main alignment angles are:

1. Camber – The inward or outward tilt of the wheel when viewed from the front.
2. Caster – The tilt of the steering axis when viewed from the side of the vehicle.
3. Toe – The direction the tyres point relative to the vehicle's centerline.

### VII. Experimental Setup



**Fig.10.1** Experimental setup of wheel Balancing.



**Fig.10.2** Experimental setup of wheel alignment.

**VIII. Required Resources/apparatus/equipment with specifications**

Sr. No.	Name of Resource	Specification	Quantity
1	Wheel Balancing Machine	Digital/Computerised	1
2	Wheel Alignment Machine	3D/CCD type	1
3	Car/Vehicle for testing	Any	1
4	Tyre Lever/Remover	Standard type	1
5	Wheel Weights	Clip-on / Stick-on	As required
6	Spanners & Wrenches Set	Metric sizes	1 set
7	Jack and Jack Stands	Hydraulic or Mechanical	1 set
8	Air Compressor (optional)	100–150 psi	1
9	Chalk/Marker	For marking wheels	1
10	Safety Equipment	Gloves, goggles, shoes	1 set

**IX. Precautions to be followed**

1. Refer to the relevant service handbook to perform wheel balancing and alignment.
2. Check tyre pressure and condition before starting.
3. Ensure the vehicle is properly secured on the ramp.
4. Clean the wheel before balancing.
5. Use only proper tools and undamaged rims.
6. Follow alignment specifications carefully.

**X. Procedure.**

- **Wheel balancing process**

1. Jack up the vehicle and remove the wheel.
2. Clean the tyre and wheel to remove dirt or debris.
3. Mount the wheel on the wheel balancing machine.
4. Enter wheel specifications (rim width, diameter, offset) into the machine.
5. Spin the wheel to detect imbalance.
6. Observe the machine display for imbalance location and weight value.
7. Attach suitable counterweights at the indicated positions (inner and outer rim).
8. Re-spin the wheel to confirm proper balance.

9. Once balanced, remove the wheel from the machine.
10. Reinstall the wheel on the vehicle and tighten the nuts properly.

- **Wheel alignment process**

1. Park the vehicle on a level surface and ensure all tyres are properly inflated.
2. Inspect the suspension and steering system for wear or damage (e.g., loose ball joints, tie rods).
3. Mount the vehicle on the alignment machine ramp and secure it in place.
4. Attach alignment sensors or targets to all four wheels.
5. Calibrate the alignment machine as per the system instructions.
6. Measure the alignment angles (camber, caster, toe) using the alignment system.
7. Compare the measured values with the manufacturer's recommended specifications.
8. Adjust the alignment angles.
9. Camber: Adjust by shifting struts or control arms.
10. Caster: Adjust through control arm position (if adjustable).
11. Toe: Adjust using tie rod ends.
12. Recheck all angles after adjustment to confirm they are within the specified range.
13. Remove the sensors, lower the vehicle and take it for a test drive to verify handling.

## XI. Observation

### 1. Observation table for Wheel Balancing

Sr. No	Tyre Position	Initial Imbalance (g)	Weight Added (g)	Final Imbalance (g)	Remarks
1	Front Left				
2	Front Right				
3	Rear Left				
4	Rear Right				
5	Stepney				



**XII. Results**

.....  
.....  
.....  
.....

**XIII. Interpretation of Results**

.....  
.....  
.....  
.....

**XIV. Conclusions and Recommendations**

.....  
.....  
.....  
.....

**XV. Practical related questions**

*Note: The following are a few sample questions for your reference. Teachers must design more such questions to ensure the achievement of the identified CO.*

- 1. Compare static and dynamic balancing. How are they different in function and application?
- 2. Explain how wheel balancing affects vehicle performance.

**[Space for Answer]**

.....  
.....  
.....  
.....  
.....  
.....  
.....  
.....  
.....  
.....  
.....  
.....  
.....  
.....  
.....  
.....  
.....  
.....  
.....  
.....  
.....

**XVI. References/Suggestions for further reading: include websites/links**

1. <https://www.youtube.com/watch?v=IqDmSMmxhtA>
2. <https://www.youtube.com/watch?v=e611N5gR1z4>

**XVII. Rubrics for Assessment Scheme**

<b>Performance Indicators</b>		<b>Weightage</b>
<b>Process Related (15 Marks)</b>		<b>(60%)</b>
1	Preparation of Practical setup, Safety measures, and standard practices	20%
2	Handling of service tools carefully while performing the practical.	20%
3	Identify the probable Causes of the Troubles, Inspection, Record Keeping, and Reassembly	20%
<b>Product Related (10 Marks)</b>		<b>(40%)</b>
4	Interpretation of the result	20%
5	Conclusions	10%
6	Practical related questions	10%
<b>Total</b>		<b>100 %</b>

<b>Marks Obtained</b>			<b>Dated signature of Teacher</b>
<b>Process Related (15)</b>	<b>Product Related (10)</b>	<b>Total (25)</b>	